

<b>TABLE OF CONTENTS</b>	<b>Page</b>
<b>Crown Moulding Patterns</b>	<b>1001</b>
<b>Casing and Base Patterns</b>	<b>2001</b>
<b>Fluted Subcategory</b>	<b>2059</b>
<b>Rail Moulding Patterns</b>	
<b>Bar Rails</b>	<b>3001</b>
<b>Chair Rails</b>	<b>3005</b>
<b>Hand Rails</b>	<b>3019</b>
<b>Panel Moulding Patterns</b>	
<b>Base Caps</b>	<b>4001</b>
<b>Panel Mouldings</b>	<b>4019</b>
<b>Picture Mouldings</b>	<b>4021</b>
<b>Tongue-and-Groove Patterns</b>	<b>5001</b>
<b>Shiplap Subcategory</b>	<b>5017</b>
<b>Other Patterns Available</b>	<b>6001</b>

Weinig is the world's leading manufacturer of moulders, having produced and installed over 40,000 moulders in more than 100 countries around the world. The company also provides knife grinders, tooling and supplies backed by service and expertise available only from Weinig.

Just as the Weinig Tooling Program assures our customers of the world's best high-performance tooling and supplies, Weinig Custom Grinding Service fills customers' grinding requirements for both standard and custom applications.

Weinig Custom Grinding Service can become your partner, helping to provide you with templates and advice to optimize your production capabilities. When you work with Weinig, we keep you current on new developments in the woodworking industry, recommending the options that will help your operation succeed.

## **WHAT WEINIG CUSTOM GRINDING CAN DO**

If you have a moulder or shaper but no knife-grinding capabilities, Weinig Custom Grinding can create and sharpen your knives. Even if you have a grinder, Weinig can assist you with gaps caused by personnel shortages, seasonal work overloads, or special applications, such as carbide knives or new profiles.

Weinig Custom Grinding Service is invaluable if your template-making service lacks production experience on moulders or grinders. Or if you must have precision templates and/or knives to ensure exact product duplication. Weinig's grinding and template-making service can also assist inexperienced operators, or help with new company startups.

**Order Now, Toll-free  
800/343-4644**

**email: [grinding@weinig.com](mailto:grinding@weinig.com)**

**NEXT PAGE**

**PREVIOUS PAGE**

**RETURN TO  
Table of Contents**

## THE PROCESS IS SIMPLE

Just send us a product sample or drawing, and we will produce a precision-dimensioned CAD drawing and send it to you for approval. Upon receipt of your approval, your made-to-order product layout, profile knives and/or templates will be shipped by two-day delivery or other method of your choice. Later, when your knives need resharpening, you are assured of the same thorough and timely service.

For customers who elect to have us perform the time-consuming task of making knives, Weinig cuts the steel, grinds the knife, and then balances the set. Your knives arrive ready to put into a head, leaving you only to resharpen the knife when it becomes dull. Weinig can provide custom templates for any profile you need to run. Choose from an existing pattern, or have us create one especially for you. All we need to work from is a simple sketch, wood sample, or CAD drawing. All our templates and precision profile knives are produced according to the Weinig Axial Constant System, which can reduce setup time by 50%. All knives are ground from Weinig Knife Steel (M3+, EHG, TCT Inlaid, or Double-Back™ Carbide) with 16-60° precision corrugations.

## WHAT YOU SHOULD EXPECT

Weinig can create templates from just about anything, but it is not realistic to expect a template to reproduce a wood sample within 0.0005". A piece of wood will shrink or expand radially 2-8% and tangentially 4-13% after machining. We generate our templates on a CAD program in conjunction with a CNC router using a 1mm bit. Our templates will be accurate within 0.001".

You should also be aware of your customer's expectations. Some people measure with a ruler to the nearest 1/16" and others use digital calipers expecting to hold tolerances of 0.002". Knowing what each of your customers needs will become very helpful in avoiding machining problems and complaints.

## OPTIONS FOR TEMPLATE DESIGN

There are several options from which Weinig can design templates for you. The most accurate is a CAD drawing of the wood product, sent on-disk or by e-mail. The others, listed in descending order of accuracy, are: CAD drawing completely dimensioned up to 0.001"; wood or other material sample from which a tracing is made and scanned into the CAD program; faxed drawing; standard patterns, available in the Wood Moulding & Millwork Producers Association's booklet and the Weinig Profile Catalog; and an idea.

In summary, the quality of reproduction is dictated by the source. If you are displeased with the fit of a template, we will send you another one at our expense.

[RETURN TO  
Table of Contents](#)

[PREVIOUS PAGE](#)

[NEXT PAGE](#)

## WHAT YOU NEED TO KNOW

There is no absolutely correct or incorrect way to run a particular moulding. The right way to run a moulding is the way that is most profitable to you. The main economic factors to consider are the costs of raw material, labor, time, overhead, and tooling.

Drawing from our years of experience and expertise, Weinig will suggest an orientation that will provide the best stability and finish for your particular machine, but it is up to you to consider all the possible options for your business. And always remember that the best plan for running your product today may require alteration as your quantity or customer specifications change.

Remember, a moulder is a value-adding machine. The product that emerges from it is worth substantially more than the raw material you put into it.

## PROFILES IMMEDIATELY AVAILABLE

Templates for all profiles in this book are available through Weinig Custom Grinding Service.

In addition to these stock templates, Weinig Custom Grinding Service also will make custom profile templates specifically for your needs. Templates can be made using other CAD drawings, a wood sample, a tracing, or only an idea.

## WEINIG PROFILE CATALOG, 3RD EDITION

This Third edition of the Weinig Profile Catalog contains most, but not all, patterns from the first edition. Send comments and suggestions to [grinding@weinig.com](mailto:grinding@weinig.com).

## CATALOG UPDATES

To keep the Weinig Profile Catalog current, we will update this 3rd edition section-by-section and make each update available to you.

Templates for all crown patterns shown in this book are available through Weinig Custom Grinding Service.

In addition to these stock templates, Weinig Custom Grinding Service also will make custom-profile templates specifically for your needs. Each computer-generated template is made using the Michael Weinig Axial Constant System.

Select your Weinig Crown Moulding from one of the following categories:

**MOULDINGS UP TO 3.25" WIDE**

**MOULDINGS FROM 3.312" WIDE TO 4" WIDE**

**MOULDINGS FROM 4.125" WIDE TO 4.5" WIDE**

**MOULDINGS FROM 4.562" WIDE TO 5.125" WIDE**

**MOULDINGS FROM 5.187" WIDE TO 5.5" WIDE**

**MOULDINGS FROM 5.625" WIDE 6.125" WIDE**

**MOULDINGS FROM 6.25" WIDE TO 7.156" WIDE**

**MOULDINGS 7.25" WIDE AND UP**

# WEINIG CROWN MOULDING PATTERNS

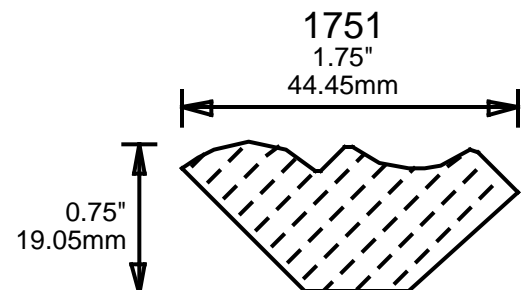
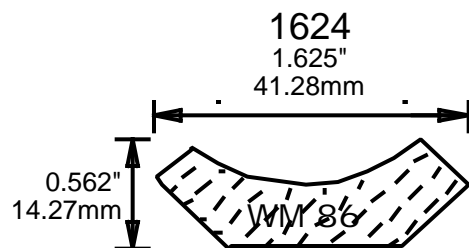
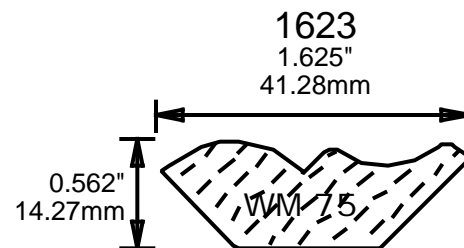
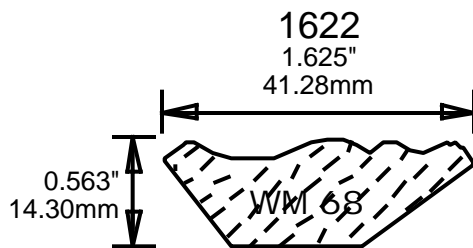
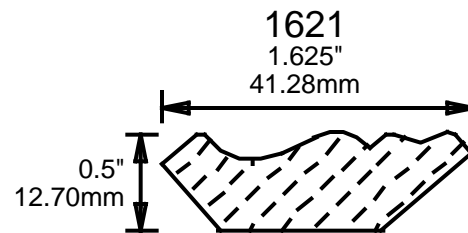
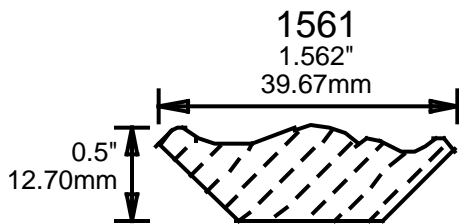
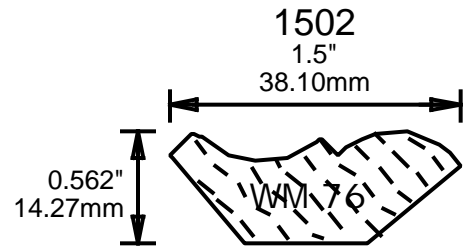
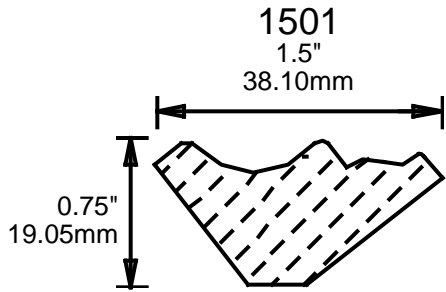

**PRINT  
THIS SECTION**

**RETURN TO  
Table of Contents**

# WEINIG CROWN MOULDING PATTERNS

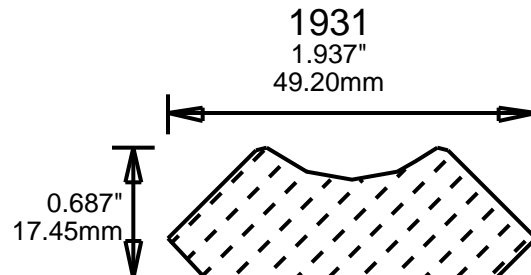
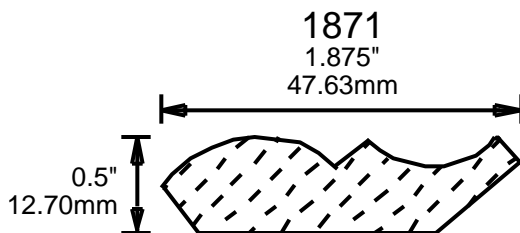
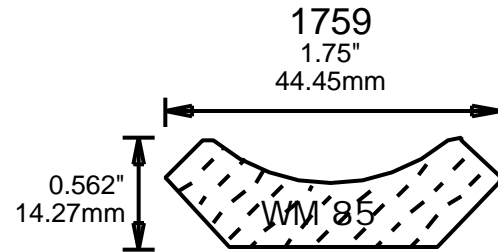
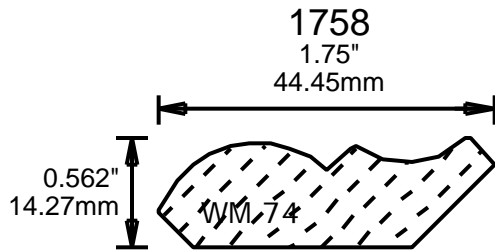
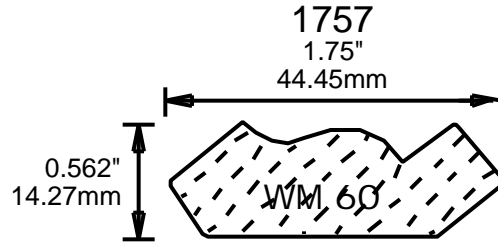
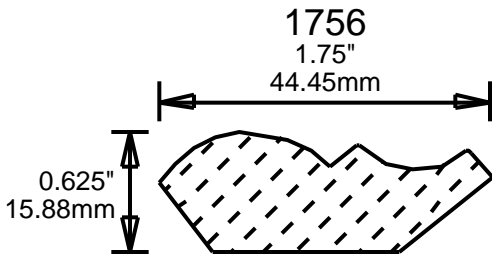
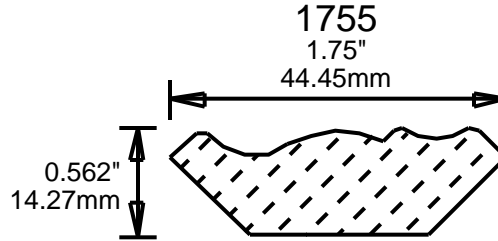
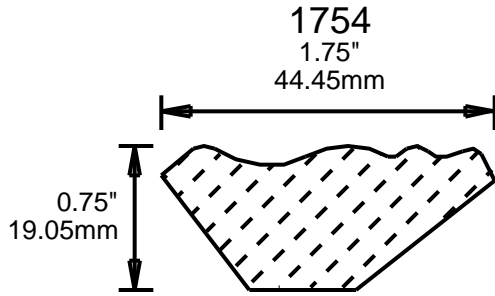
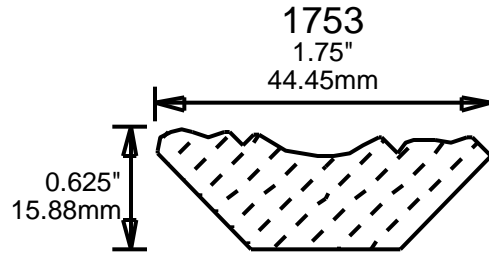
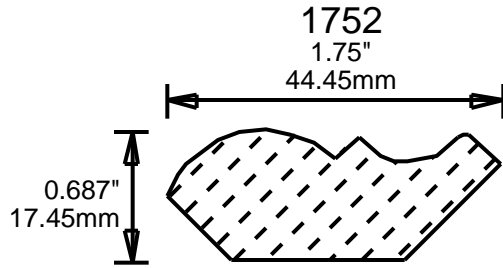

# WEINIG CROWN MOULDING PATTERNS

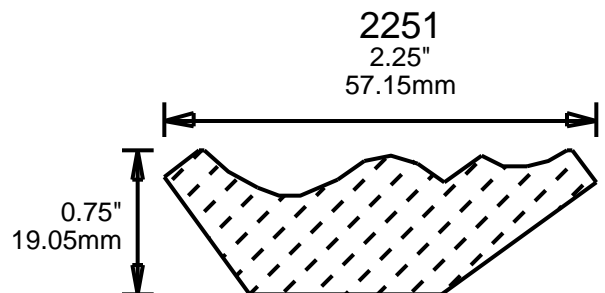
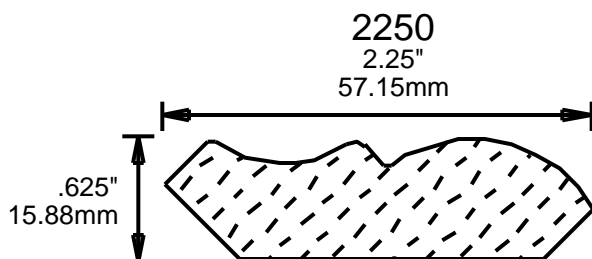
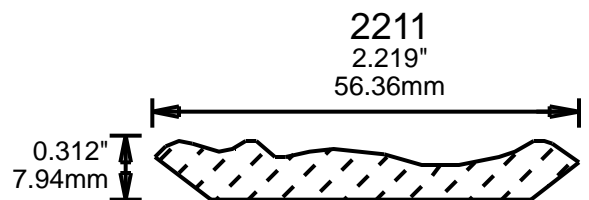
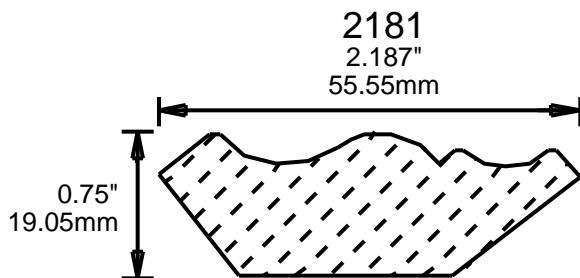
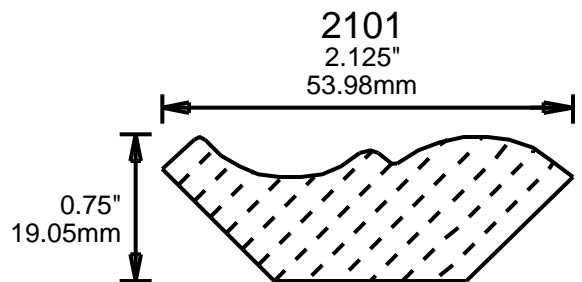
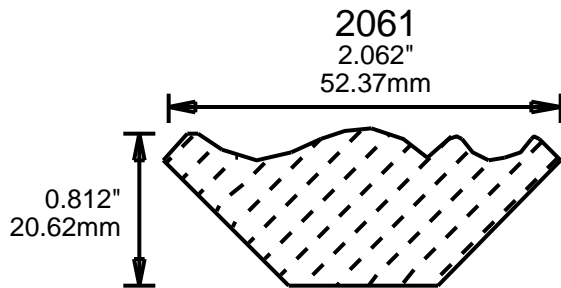
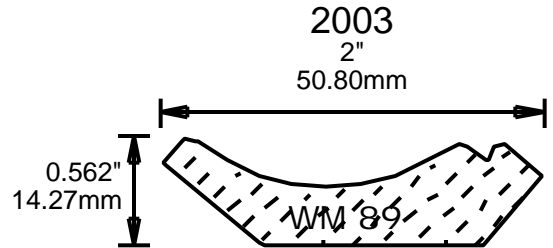
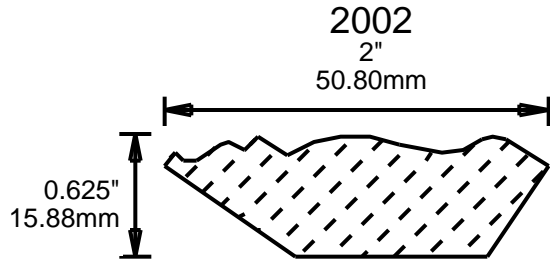
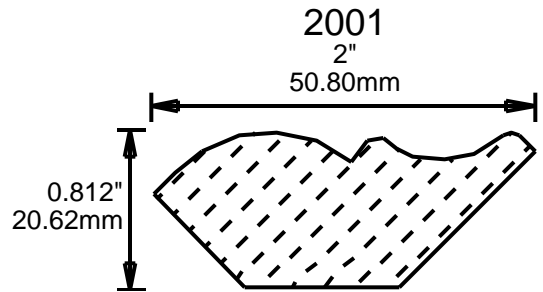
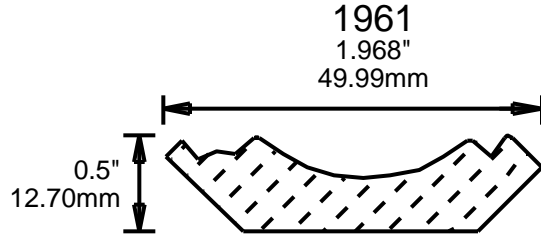



# WEINIG CROWN MOULDING PATTERNS

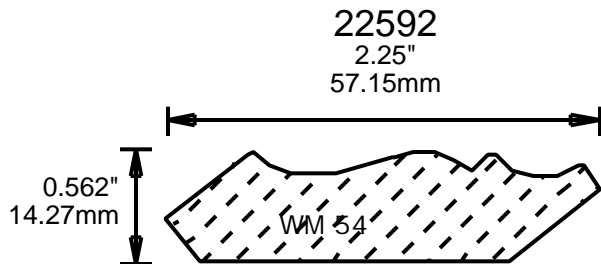
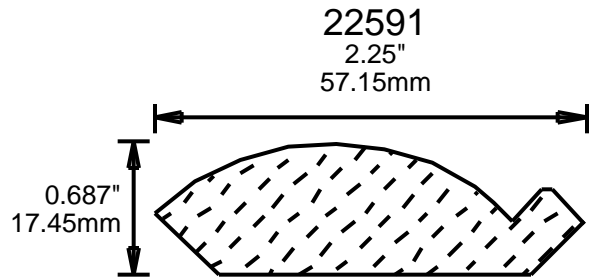
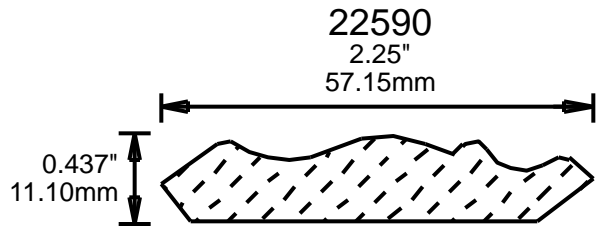
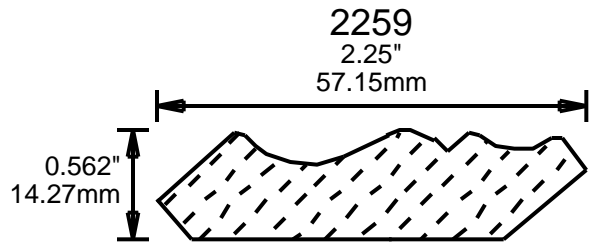
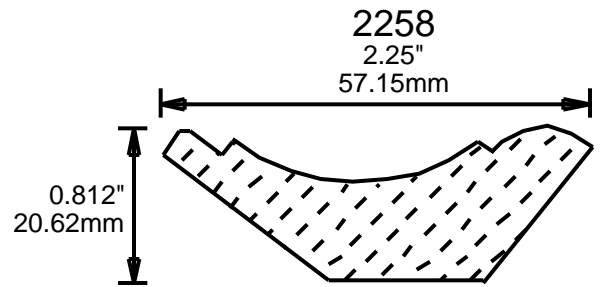
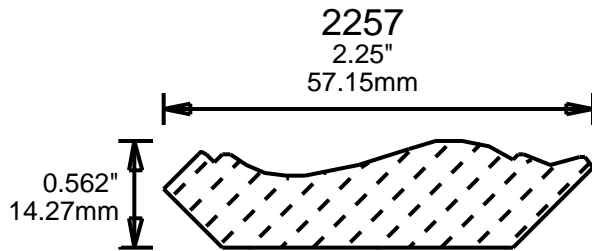
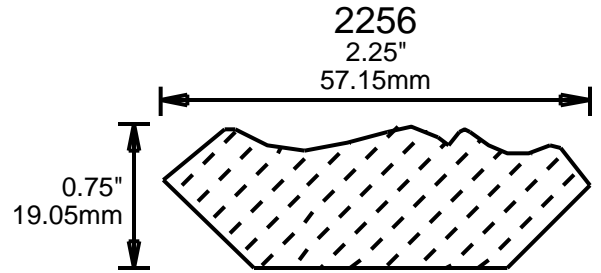
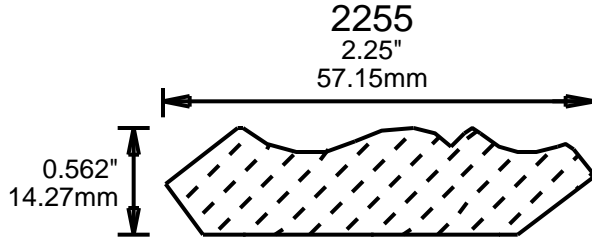
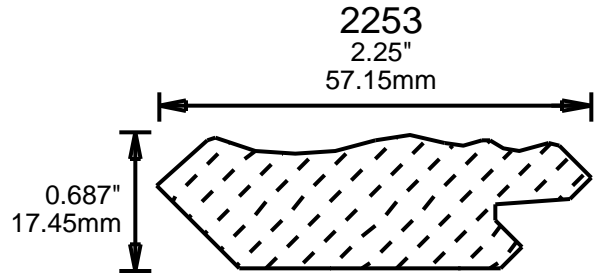
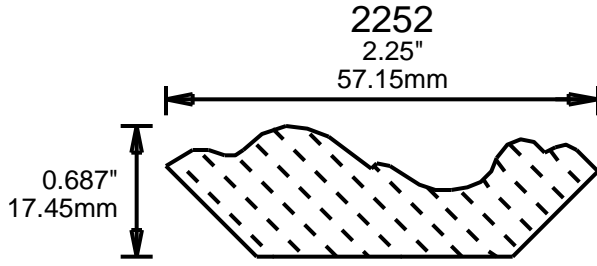

# WEINIG CROWN MOULDING PATTERNS

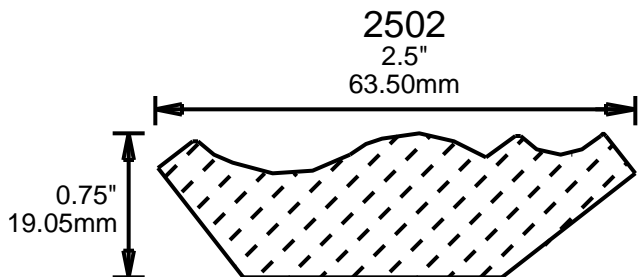
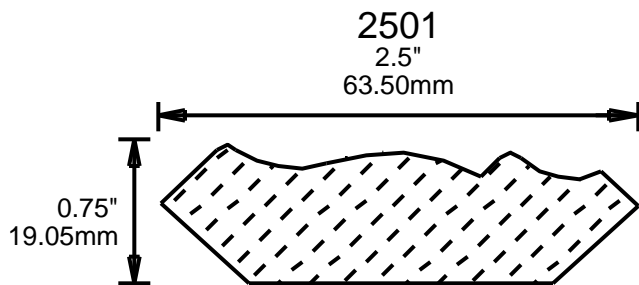
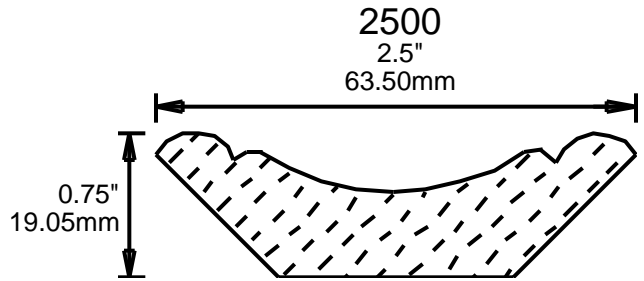
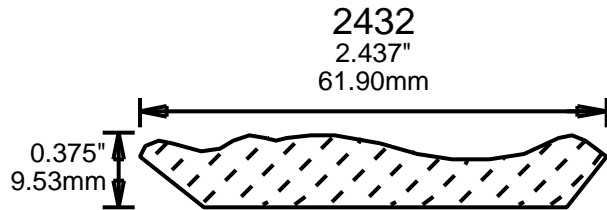
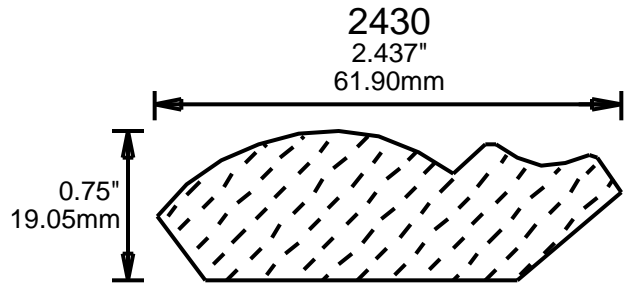
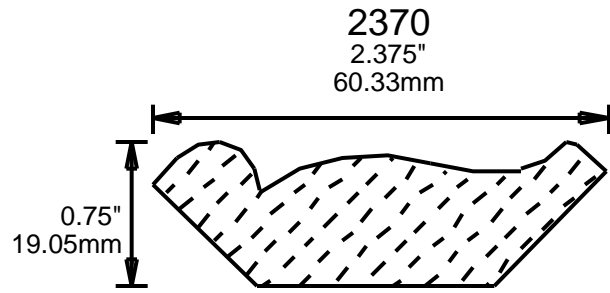
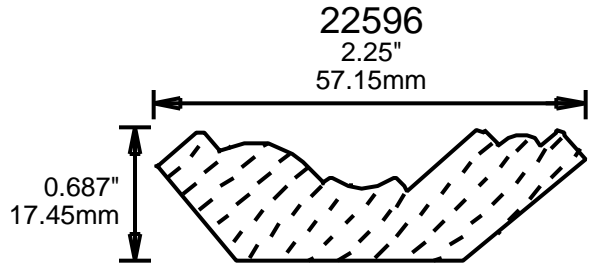
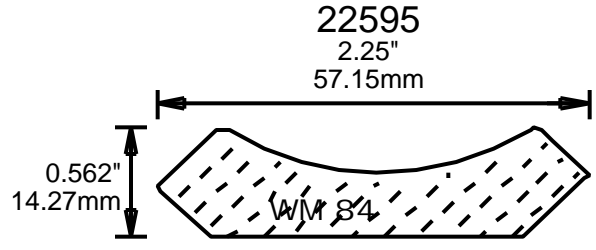
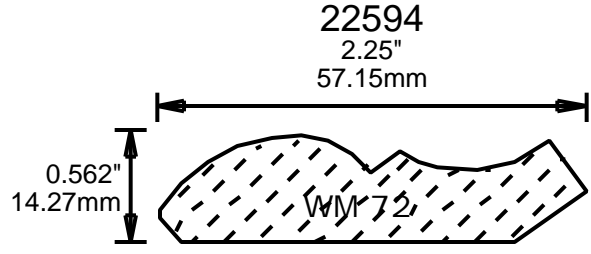
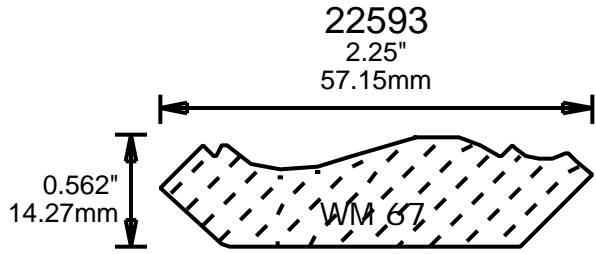

# WEINIG CROWN MOULDING PATTERNS

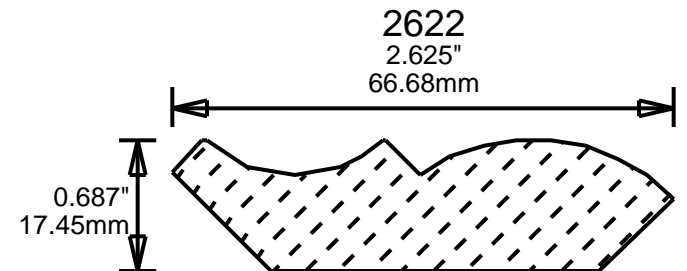
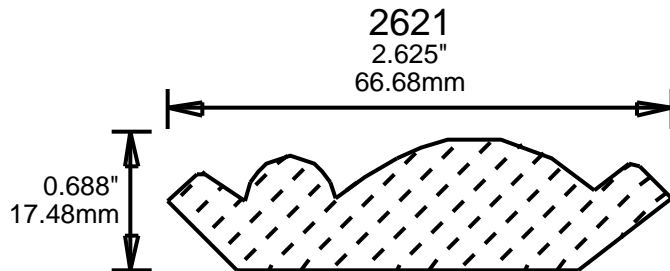
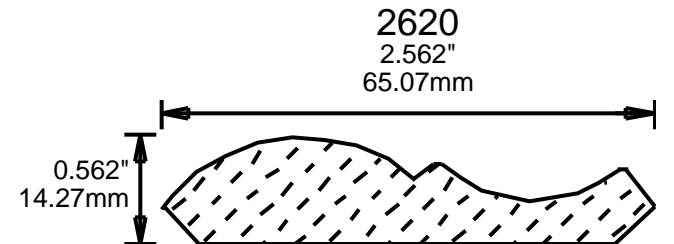
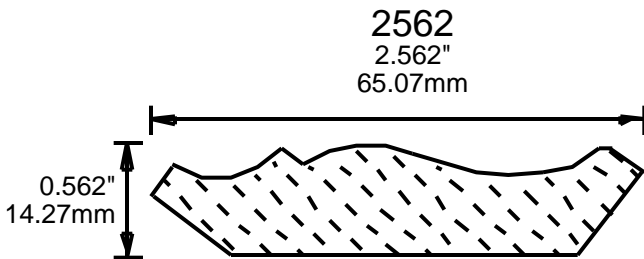
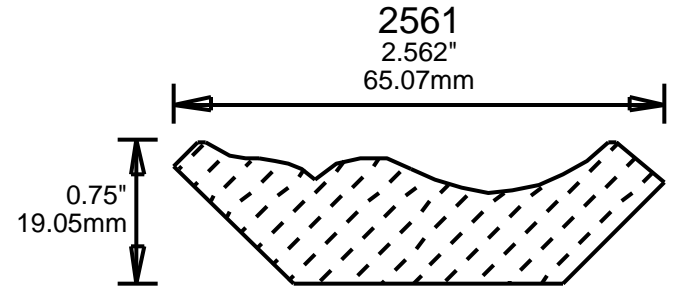
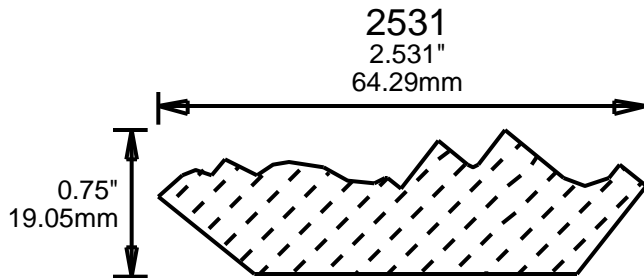
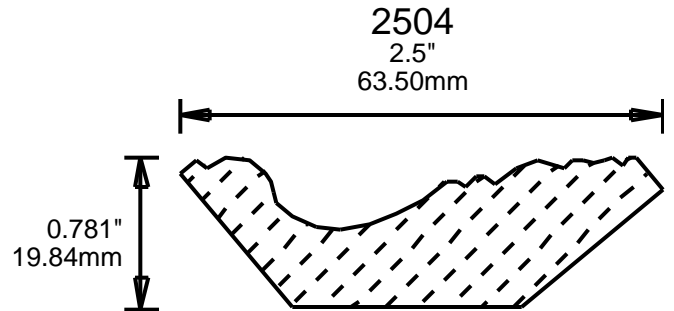
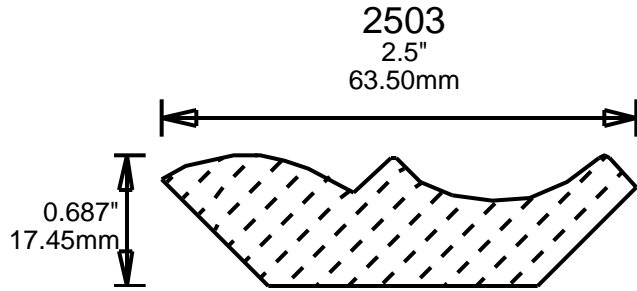

# WEINIG CROWN MOULDING PATTERNS

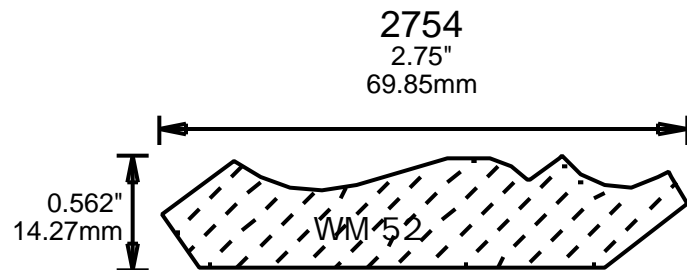
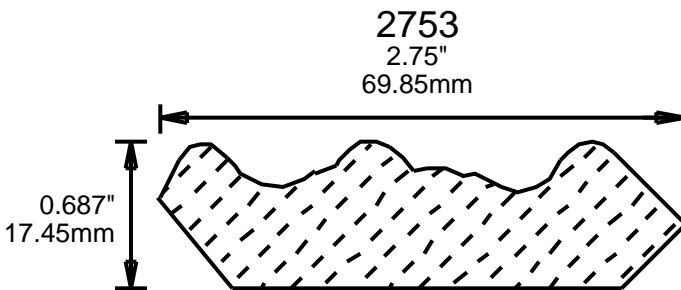
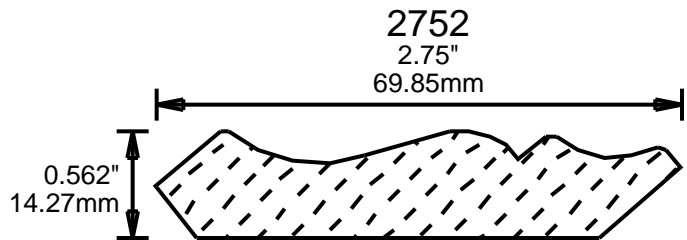
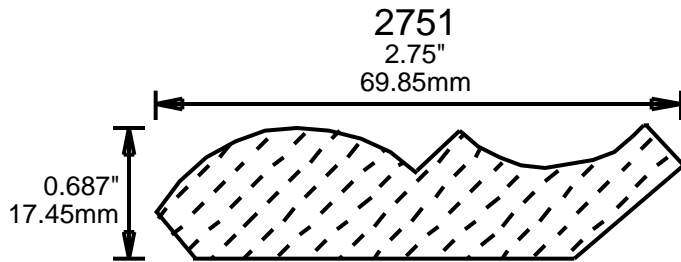
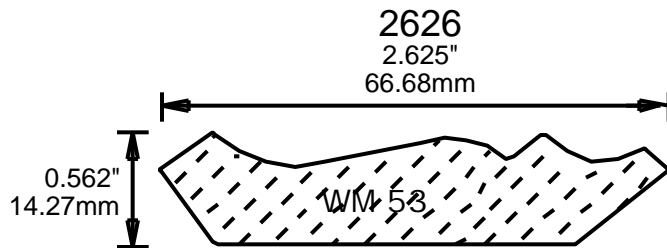
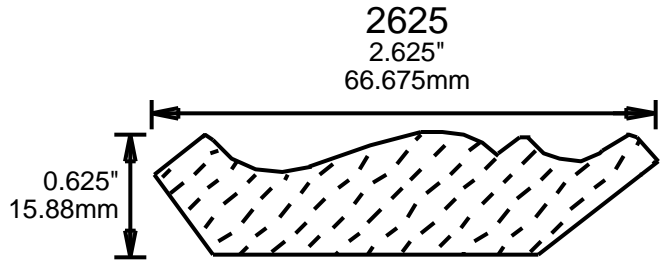
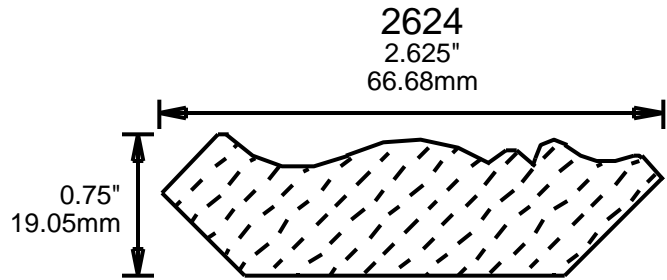
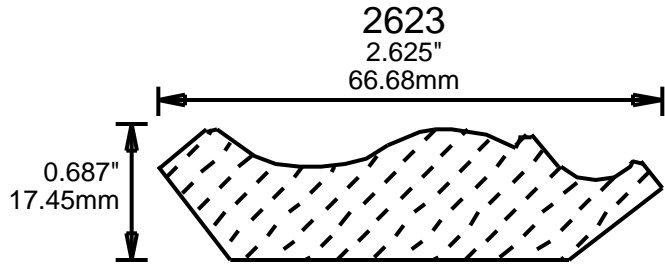

# WEINIG CROWN MOULDING PATTERNS

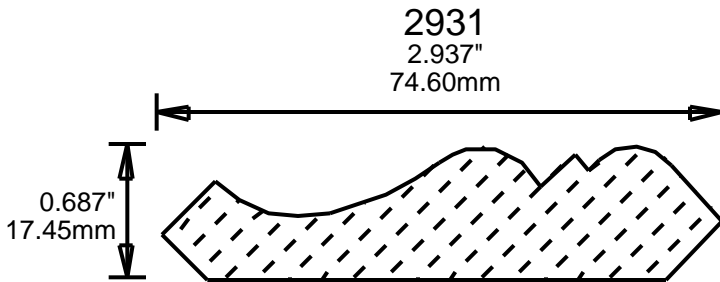
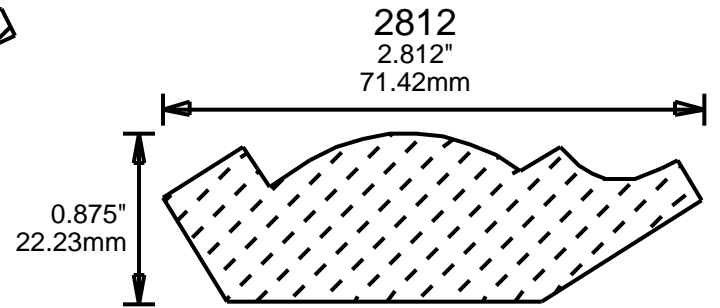
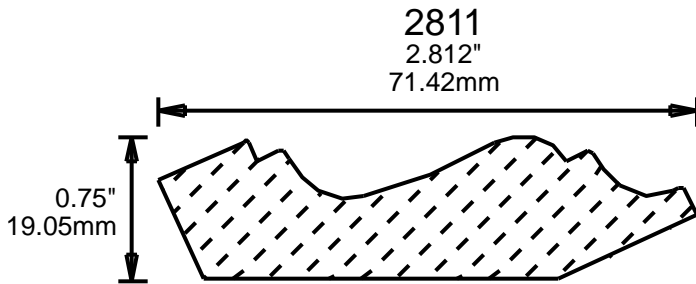
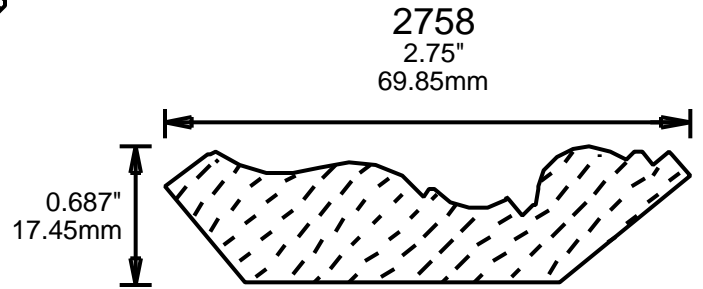
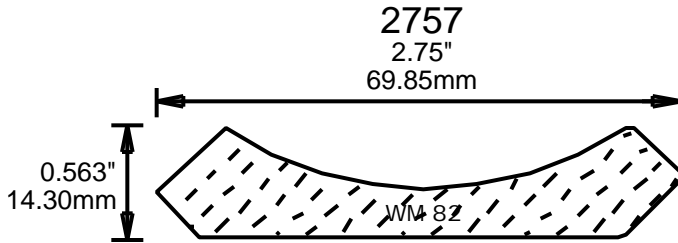
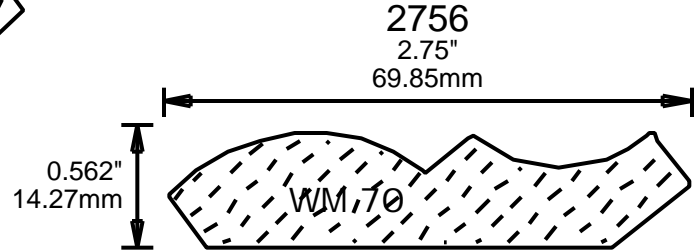
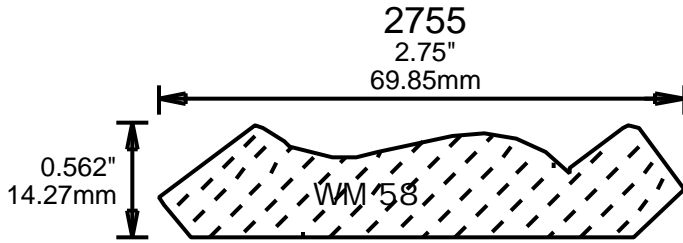

# WEINIG CROWN MOULDING PATTERNS

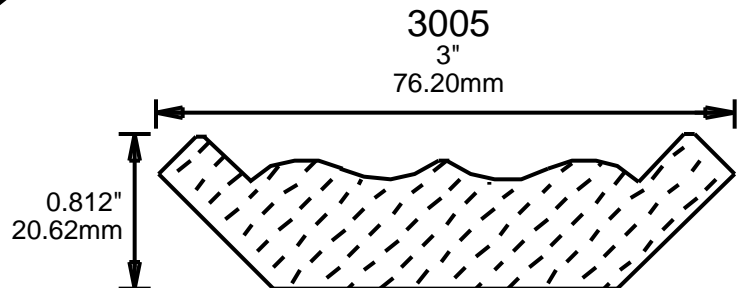
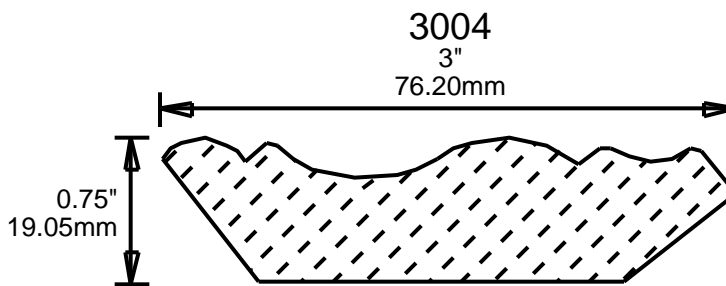
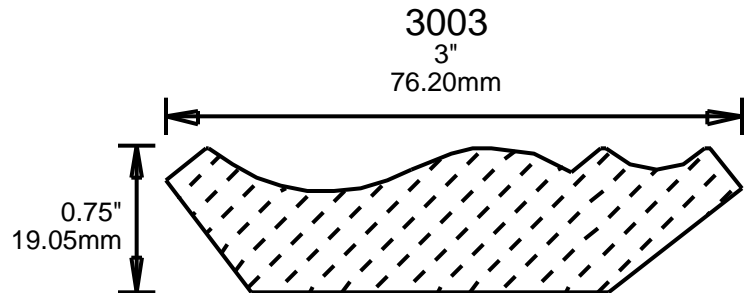
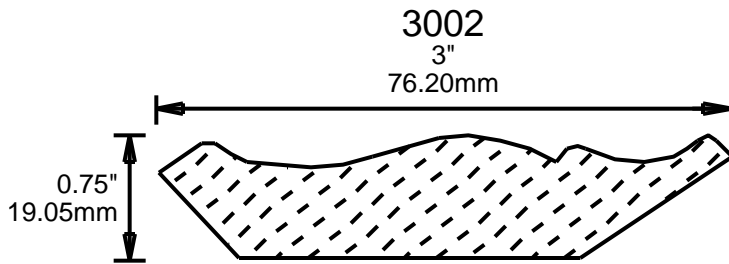
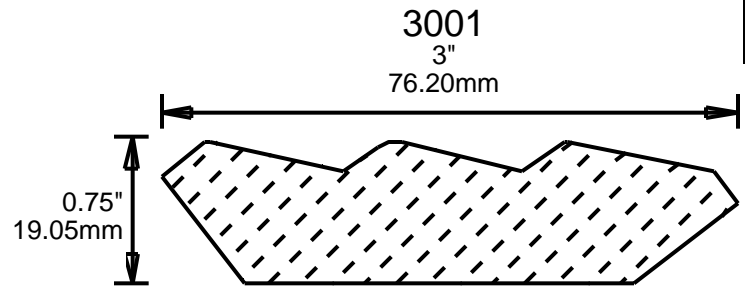
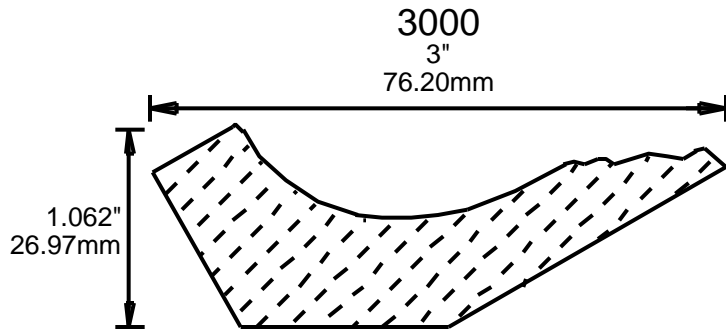

# WEINIG CROWN MOULDING PATTERNS

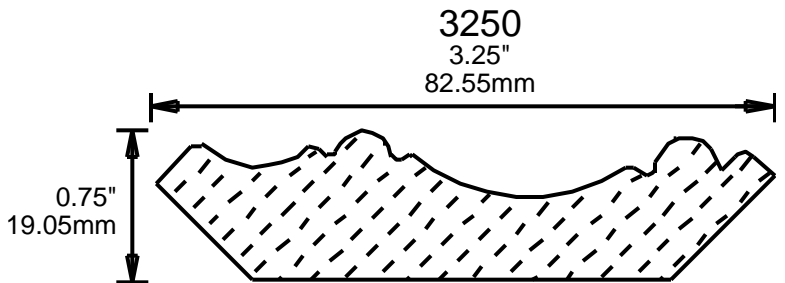
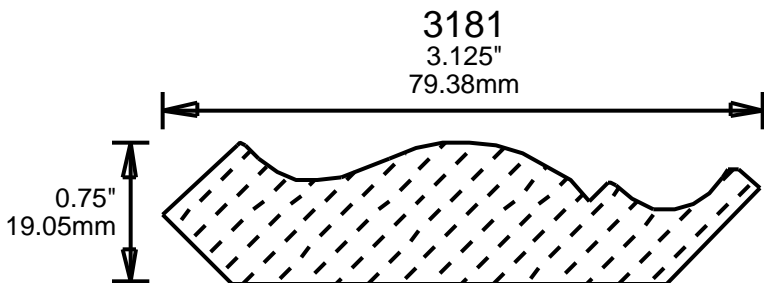
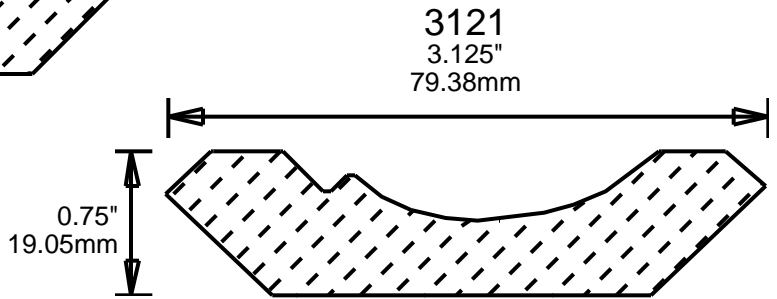
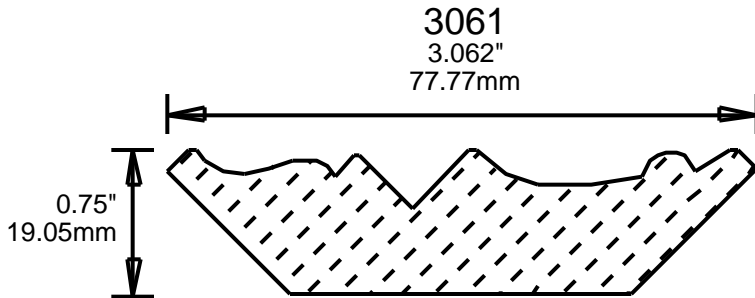
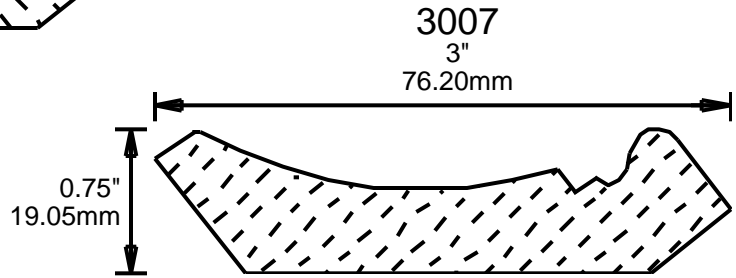
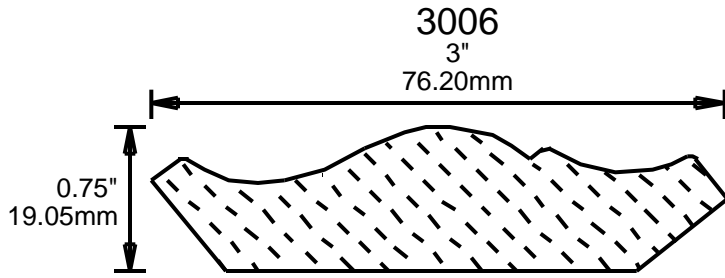

# WEINIG CROWN MOULDING PATTERNS

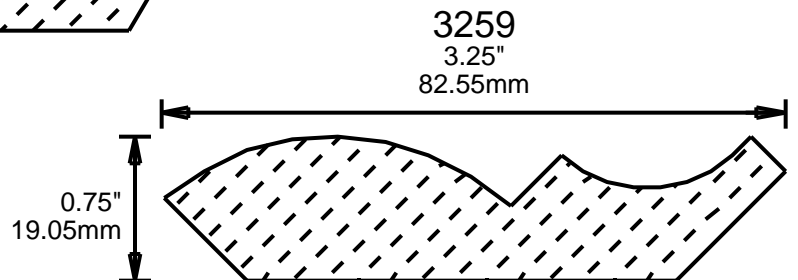
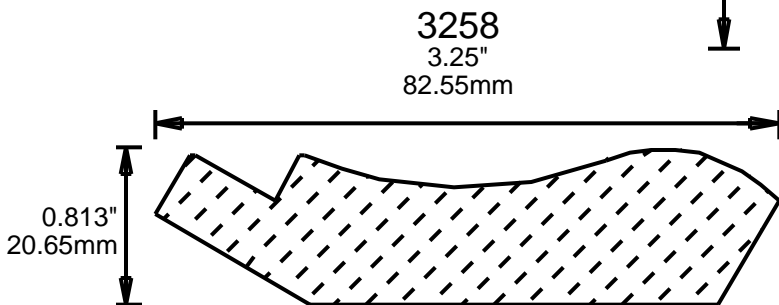
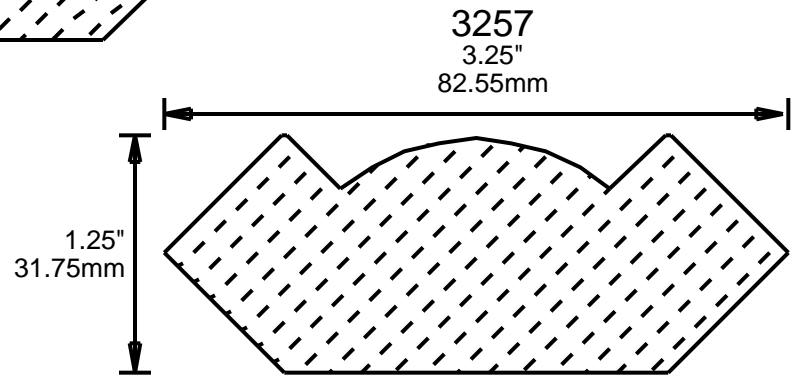
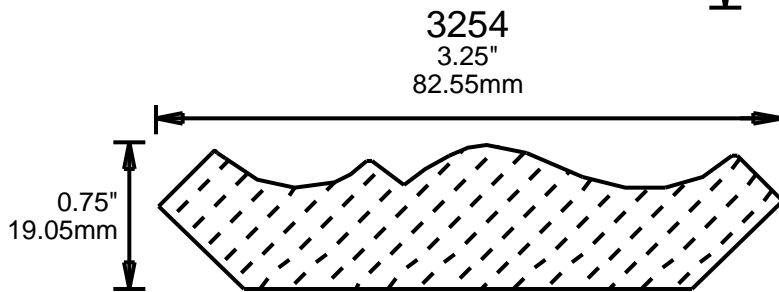
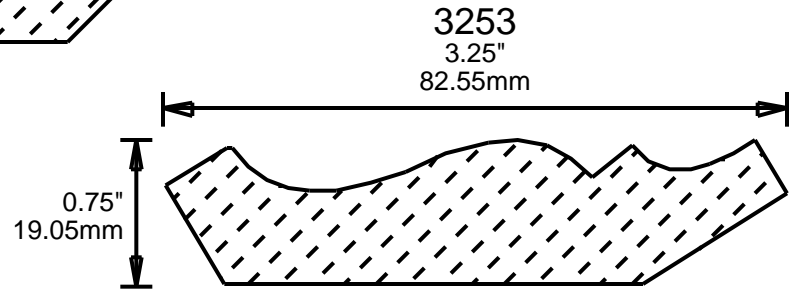
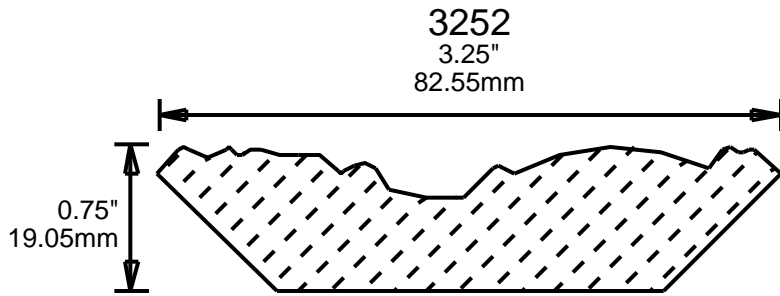



# WEINIG CROWN MOULDING PATTERNS

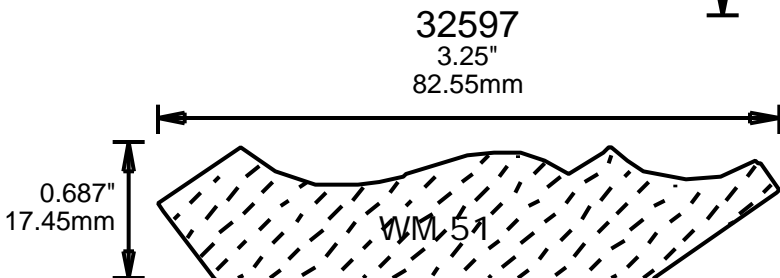
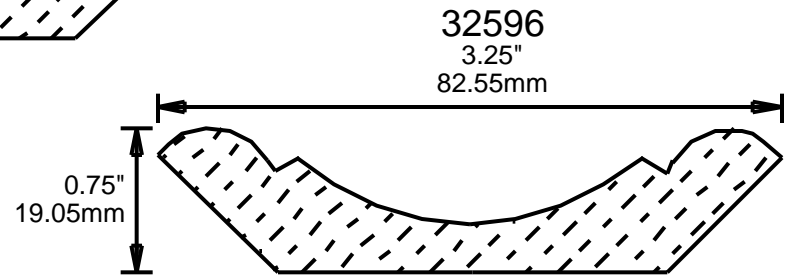
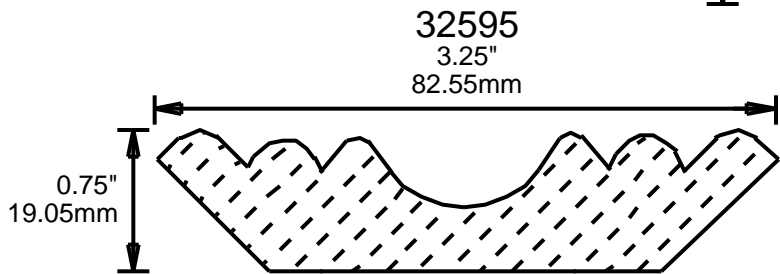
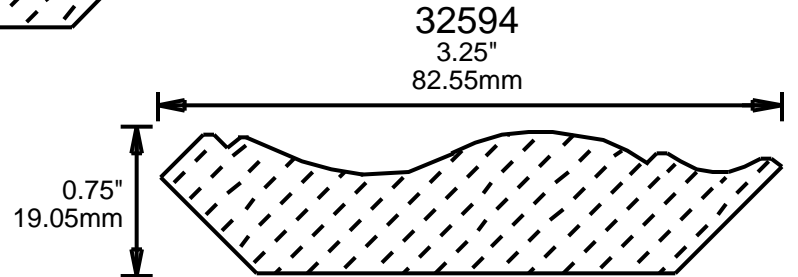
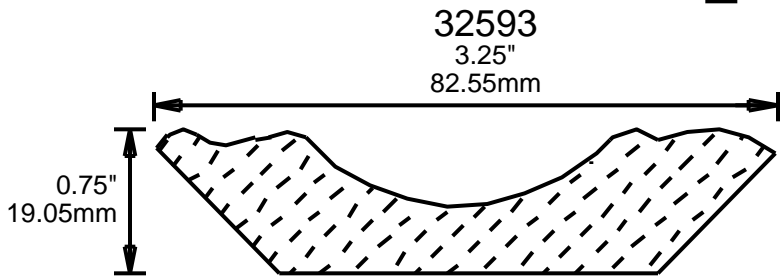
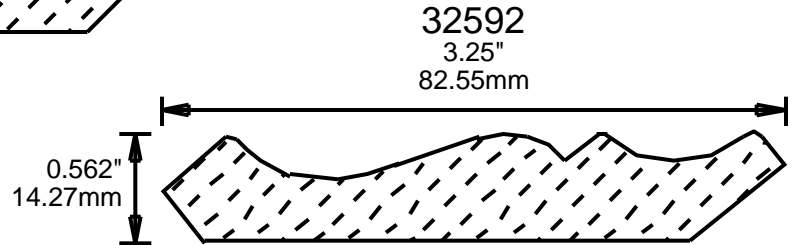
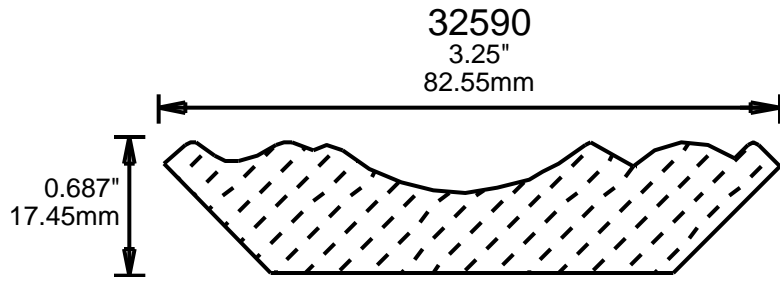

# WEINIG CROWN MOULDING PATTERNS

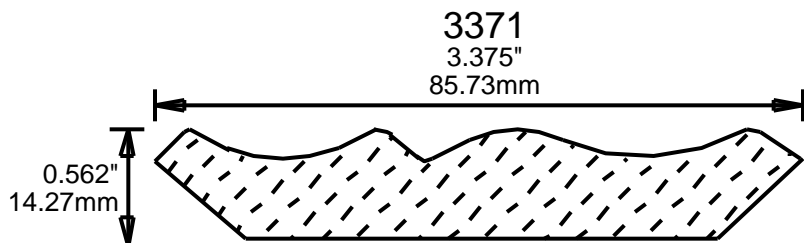
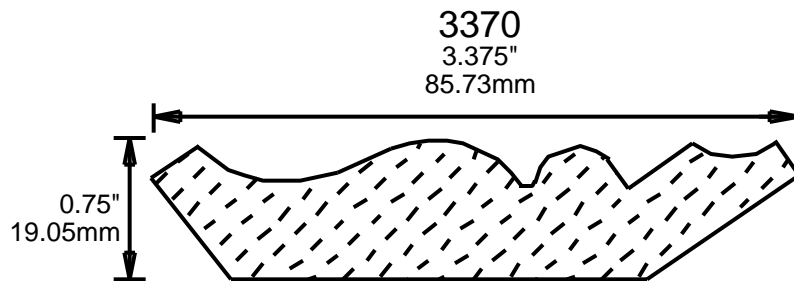
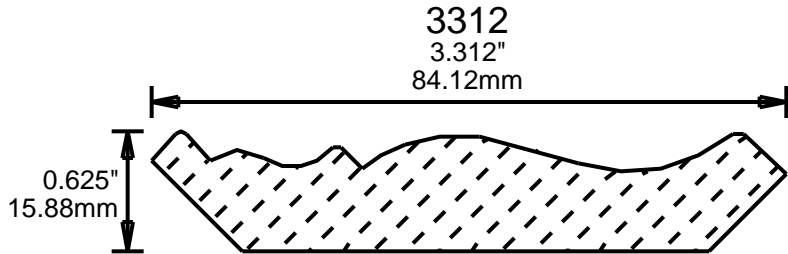
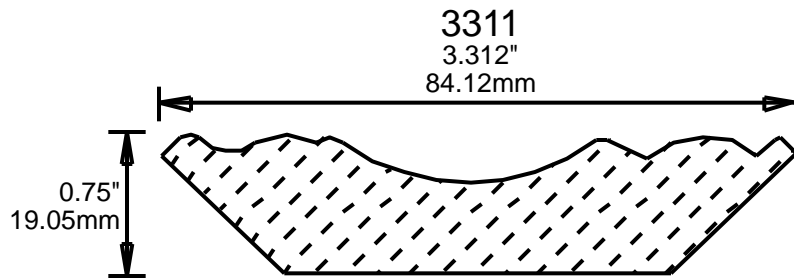
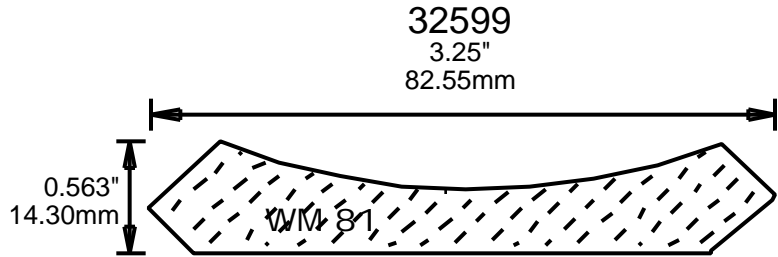
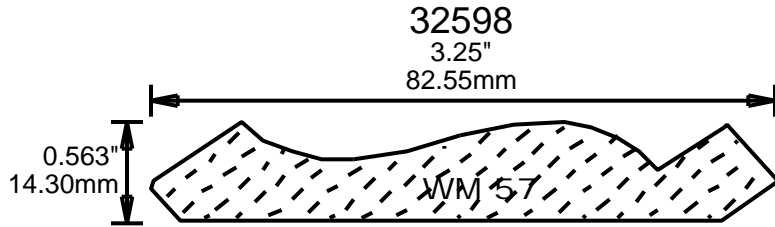

# WEINIG CROWN MOULDING PATTERNS

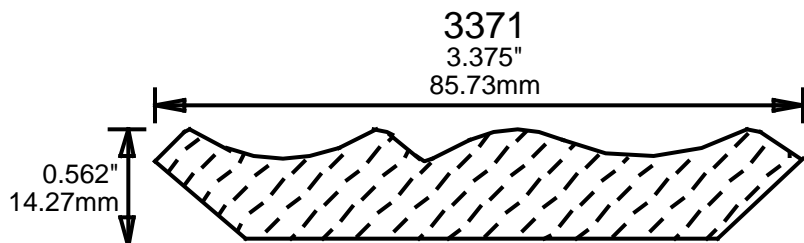
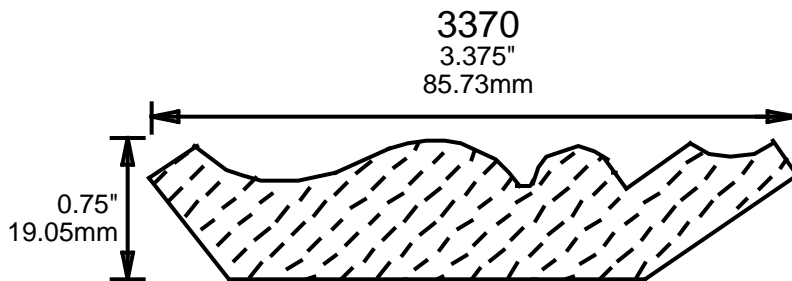
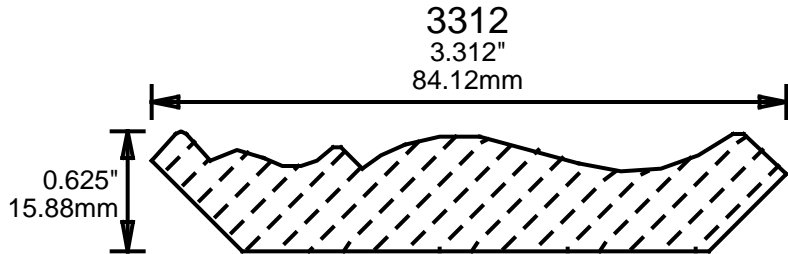
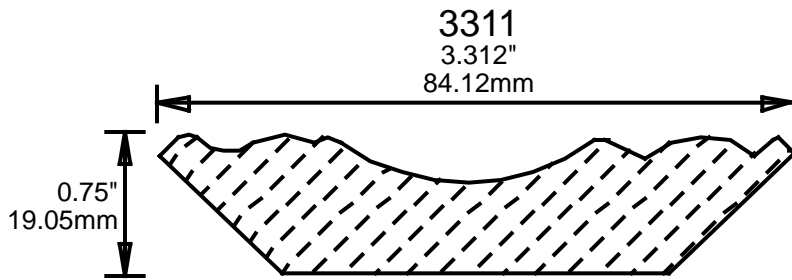
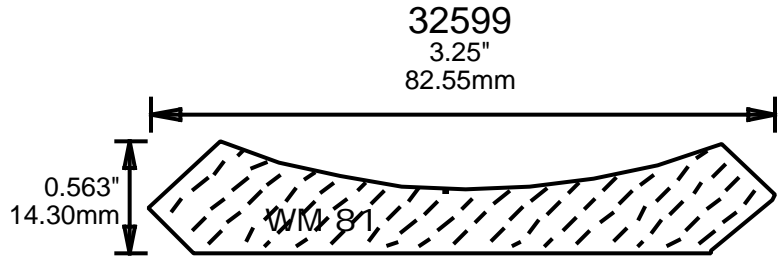
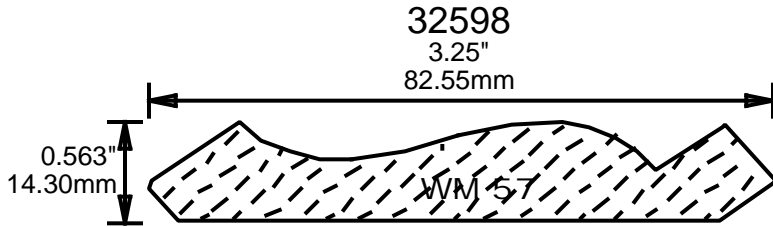

# WEINIG CROWN MOULDING PATTERNS

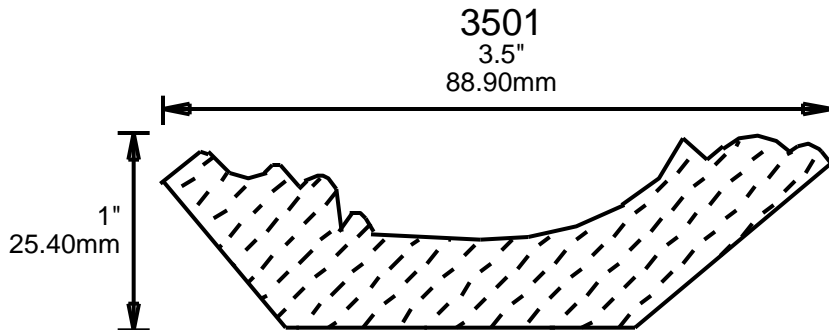
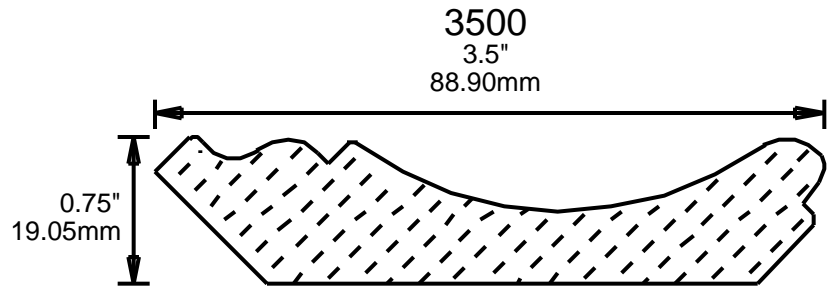
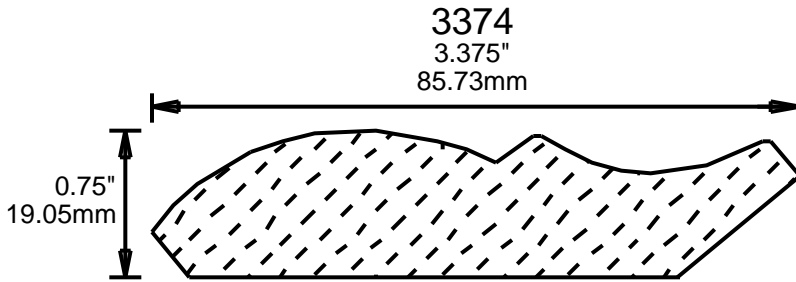
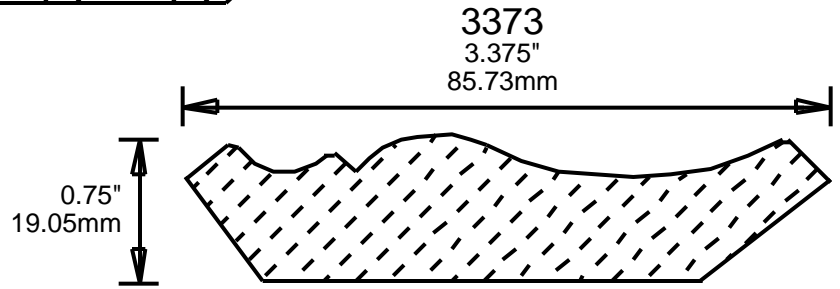
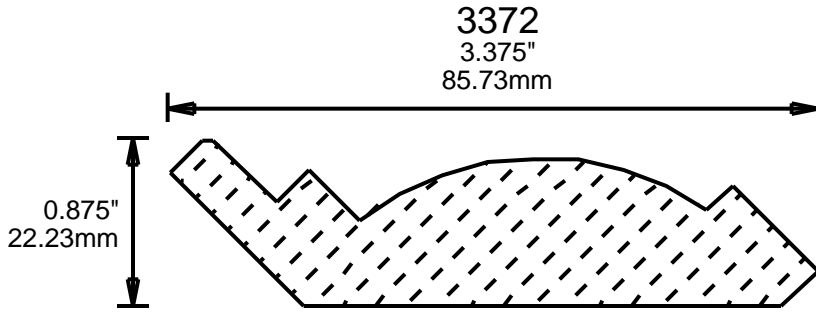

# WEINIG CROWN MOULDING PATTERNS

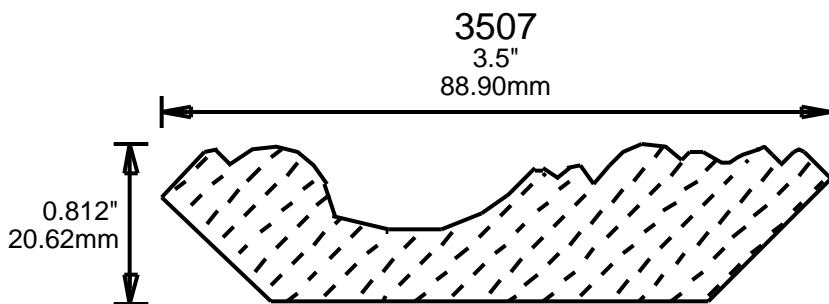
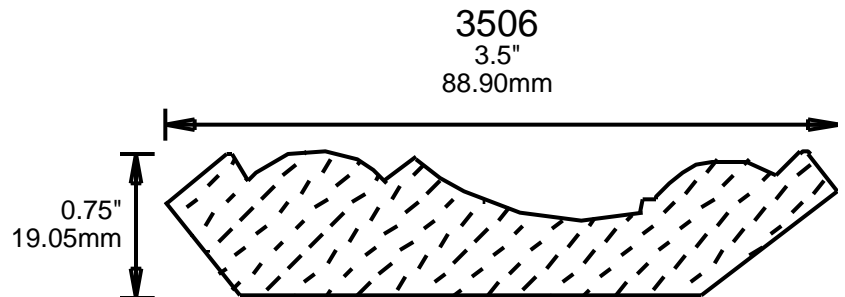
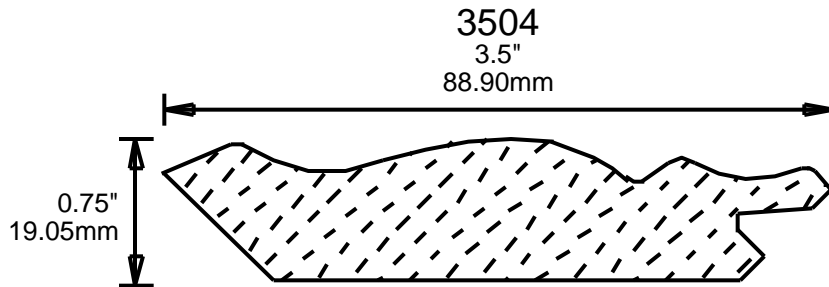
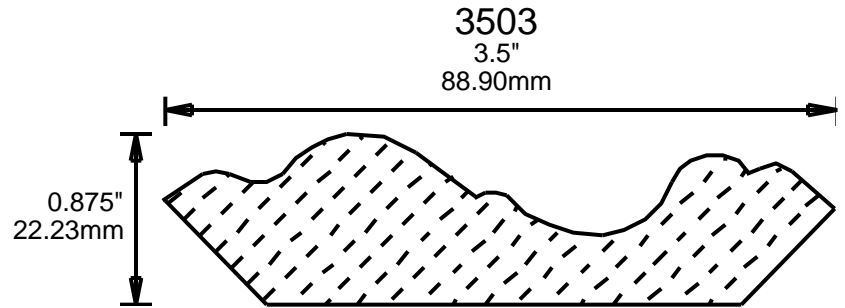
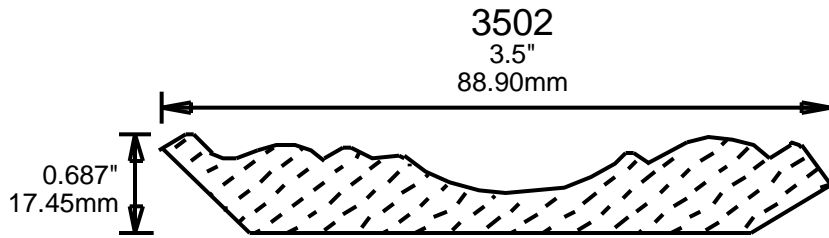

# WEINIG CROWN MOULDING PATTERNS

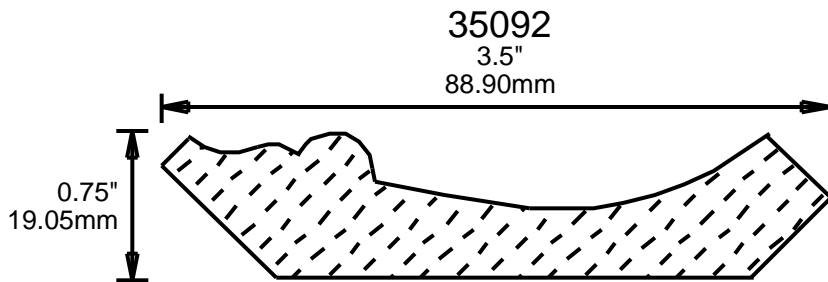
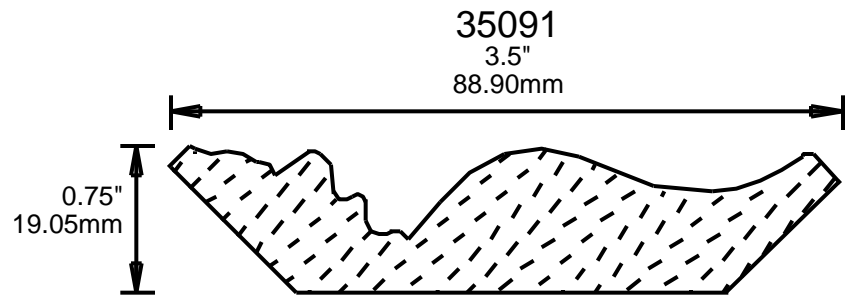
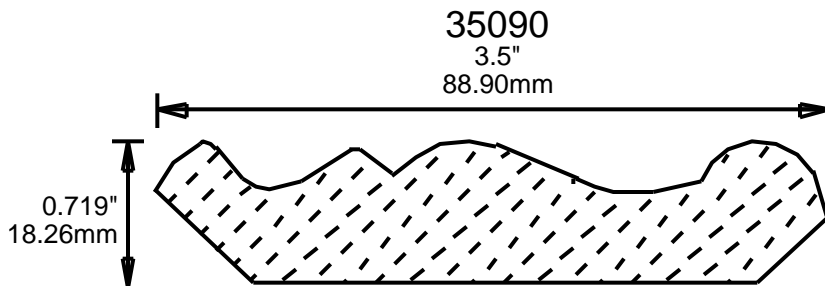
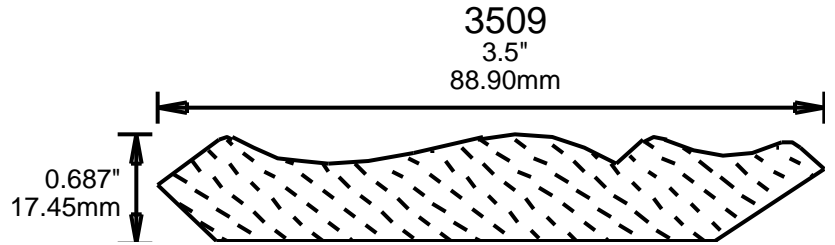
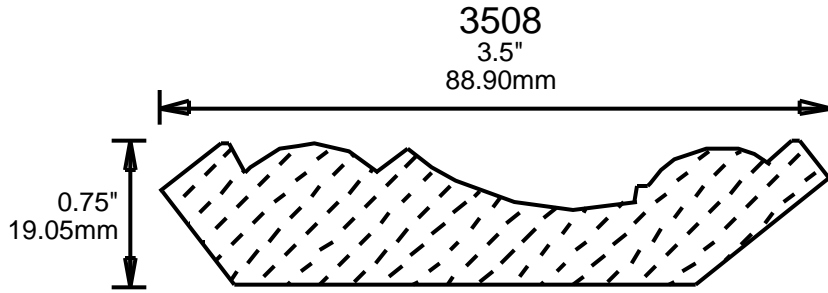

# WEINIG CROWN MOULDING PATTERNS

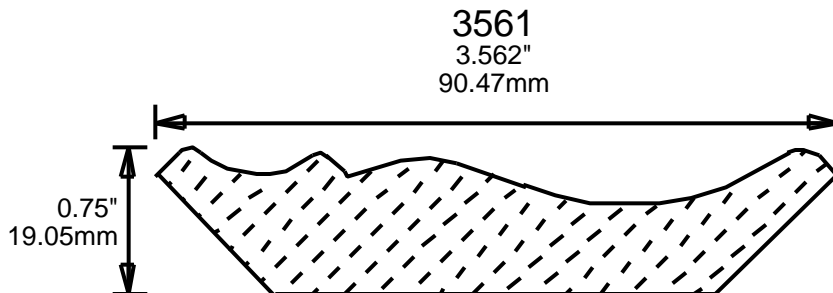
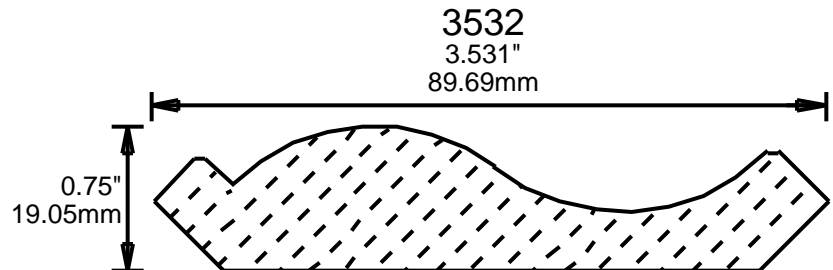
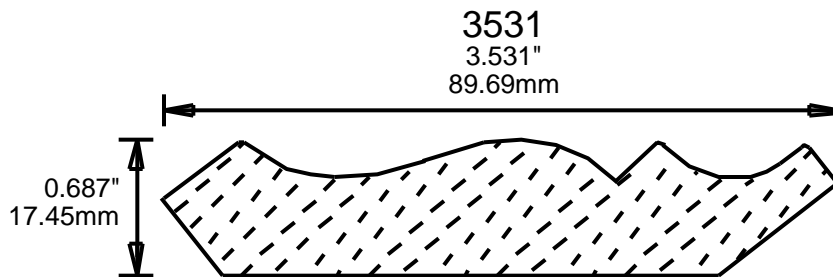
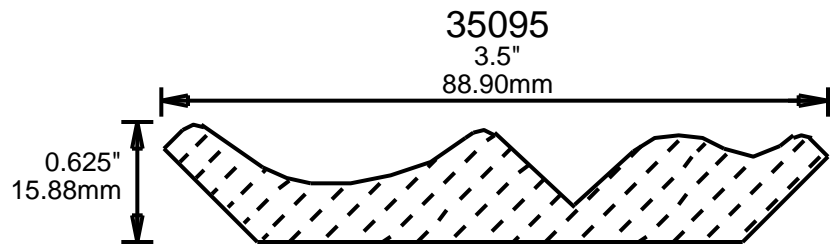
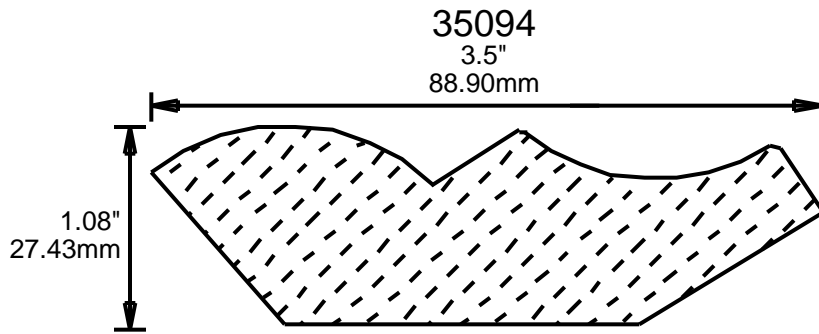

# WEINIG CROWN MOULDING PATTERNS

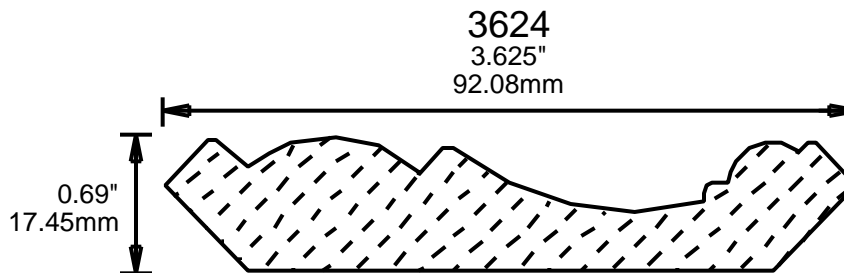
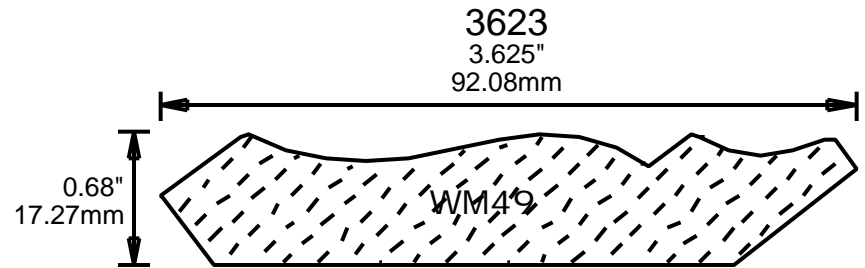
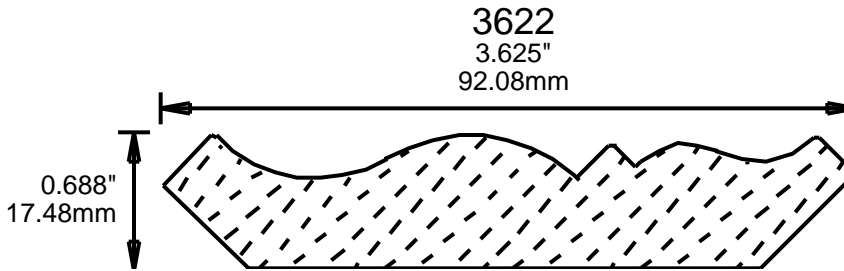
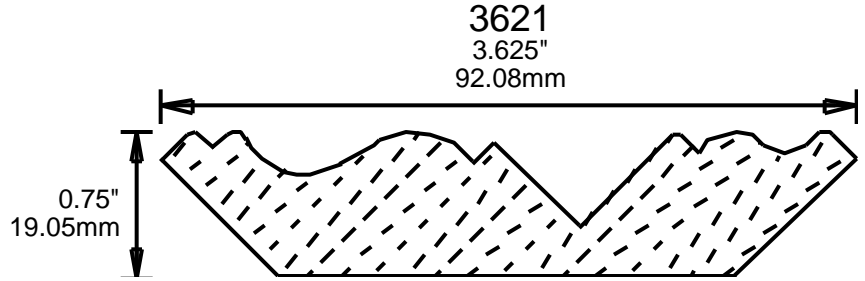
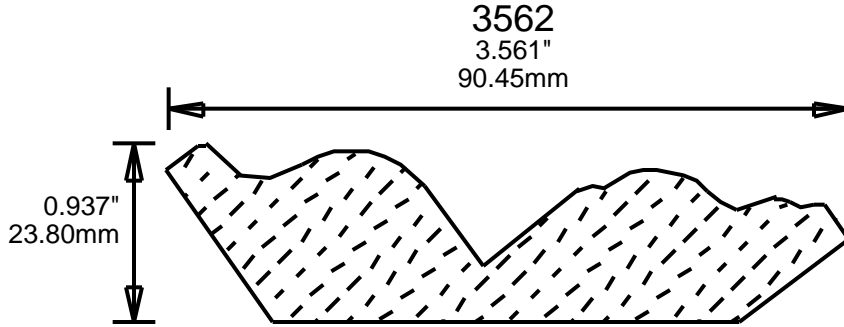



# WEINIG CROWN MOULDING PATTERNS

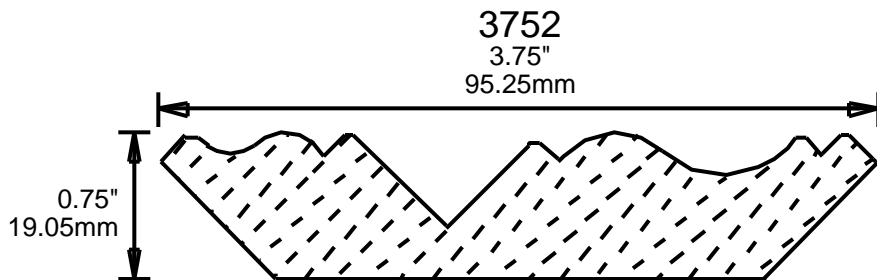
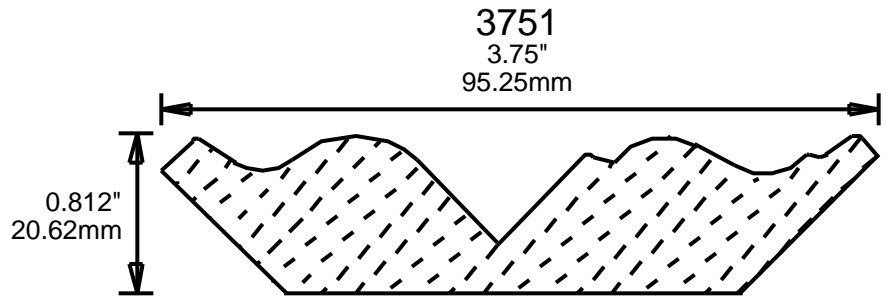
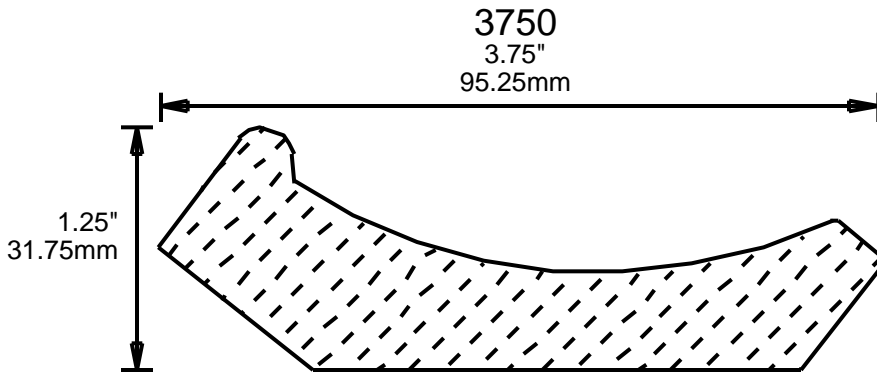
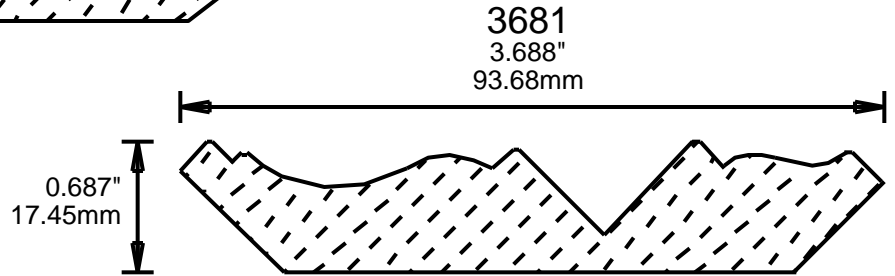
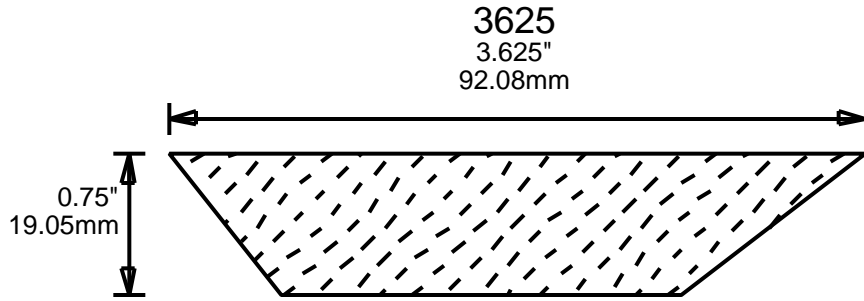

# WEINIG CROWN MOULDING PATTERNS

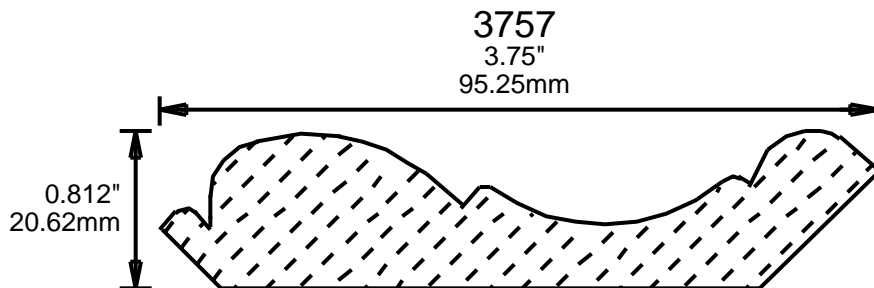
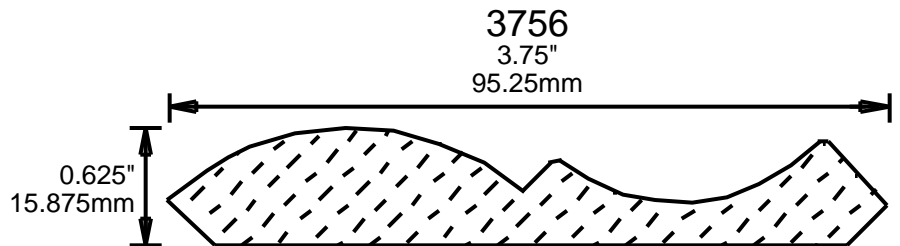
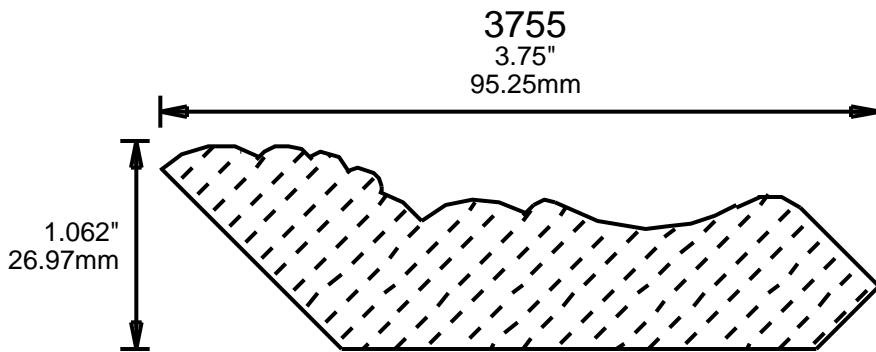
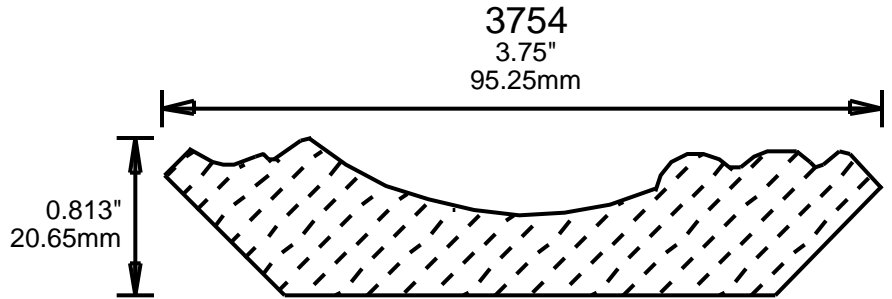
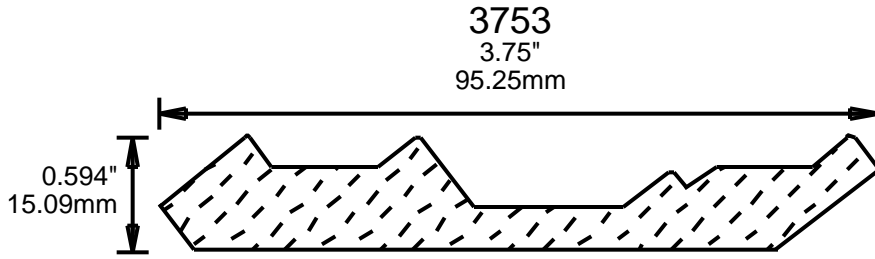

# WEINIG CROWN MOULDING PATTERNS

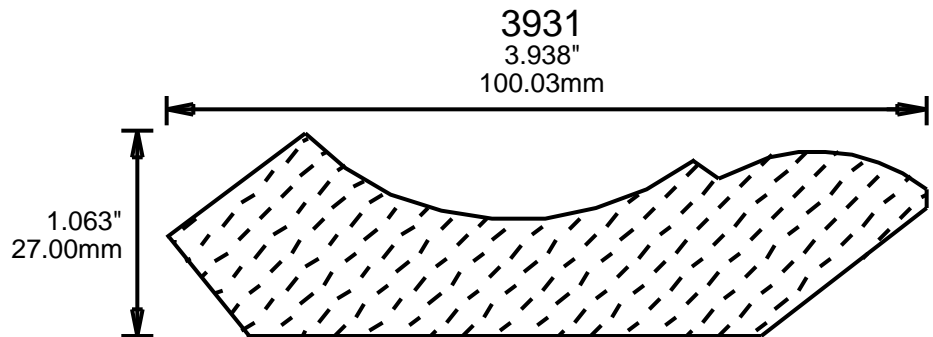
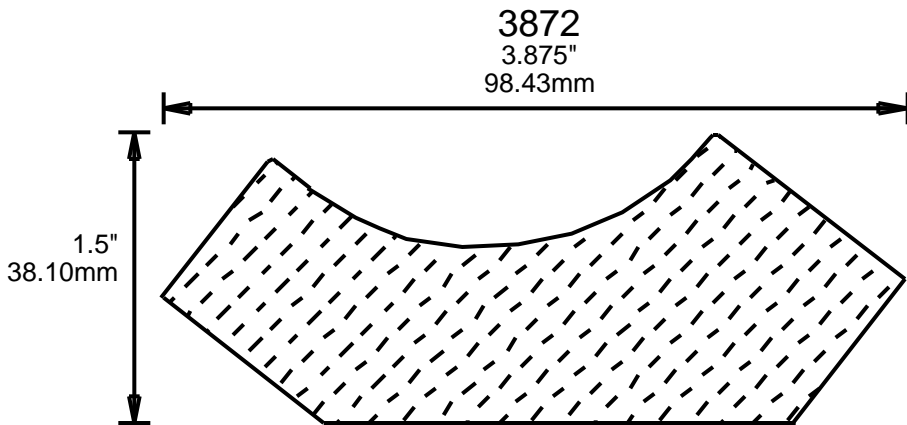
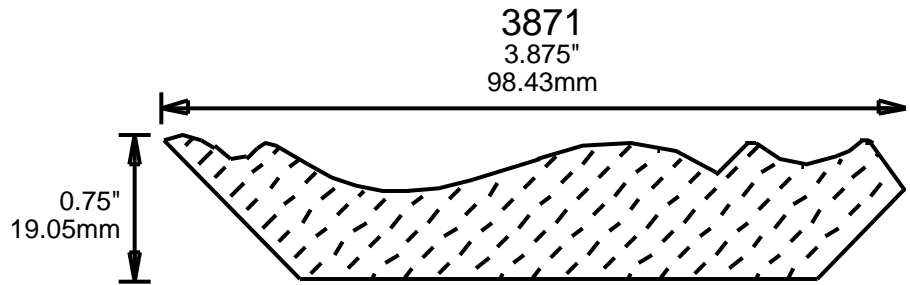
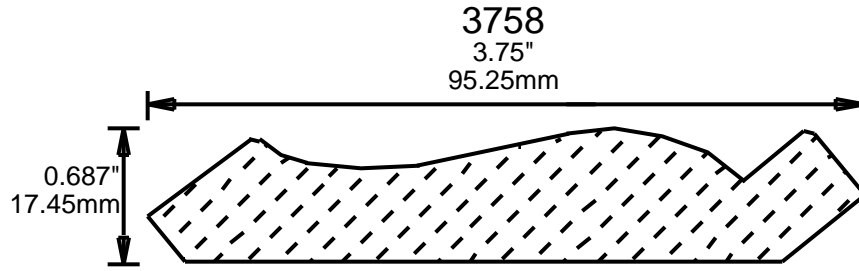

# WEINIG CROWN MOULDING PATTERNS

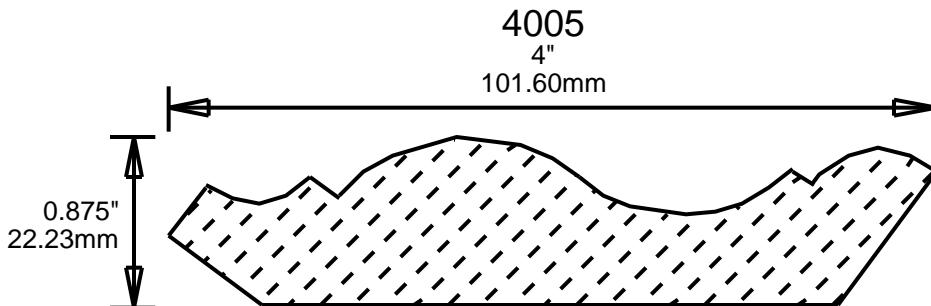
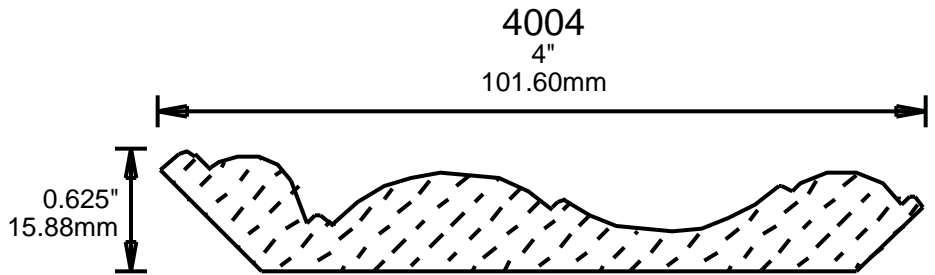
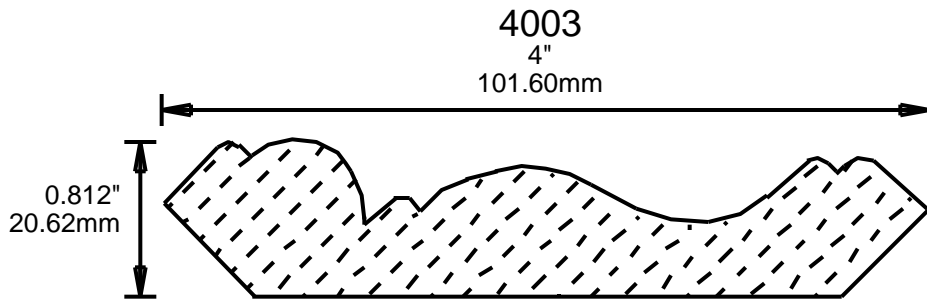
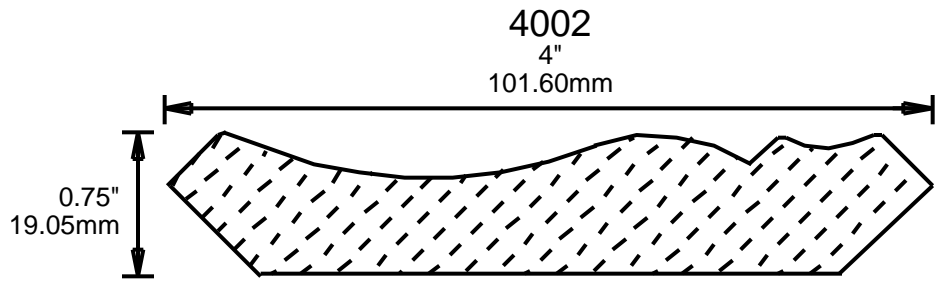
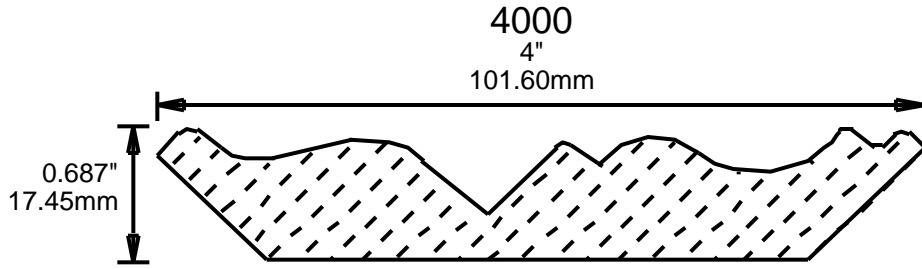

# WEINIG CROWN MOULDING PATTERNS

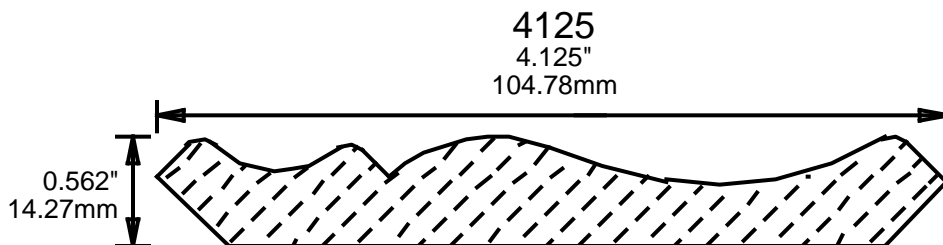
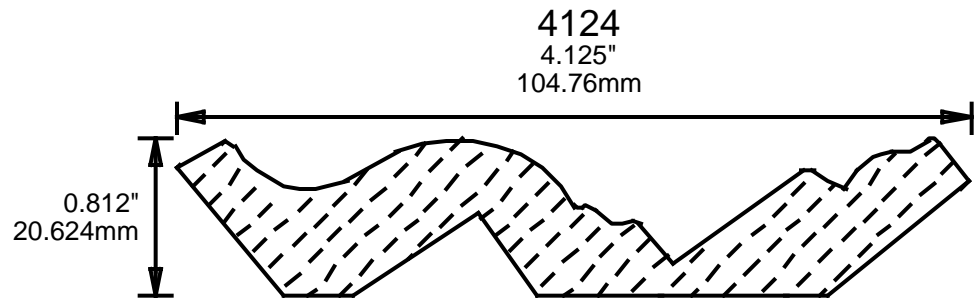
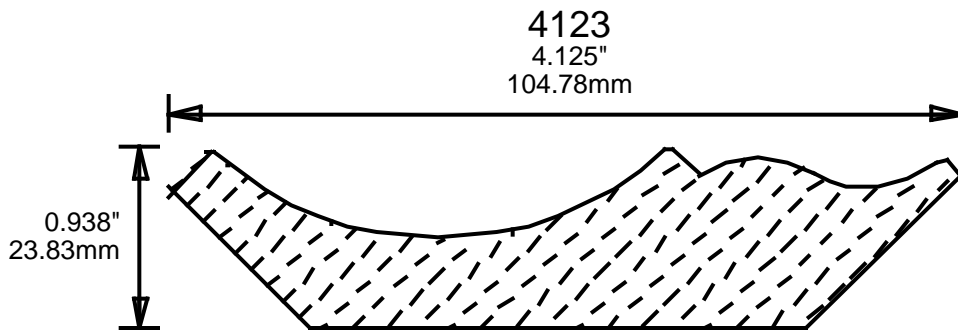
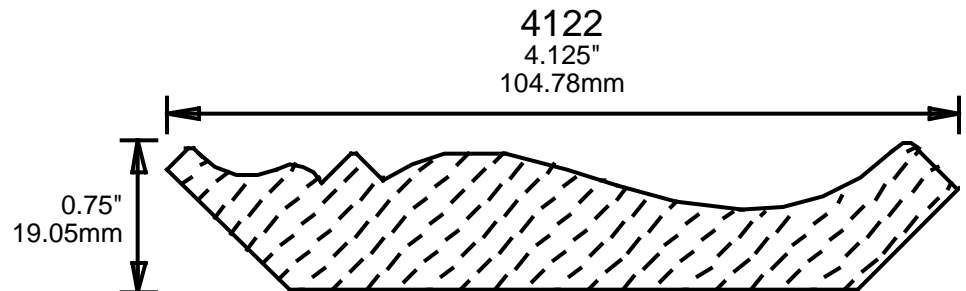
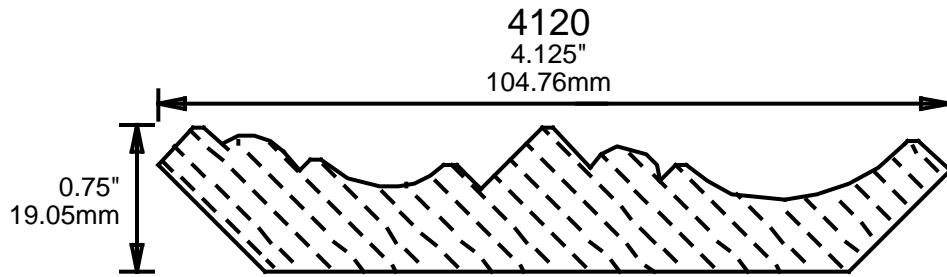

# WEINIG CROWN MOULDING PATTERNS

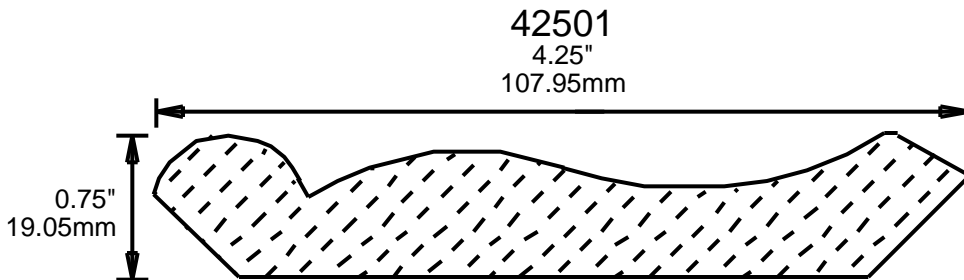
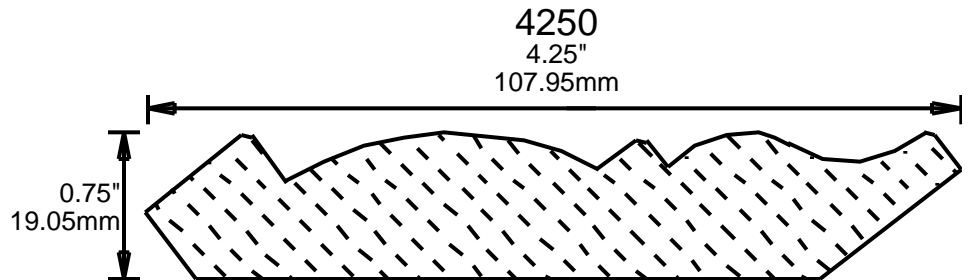
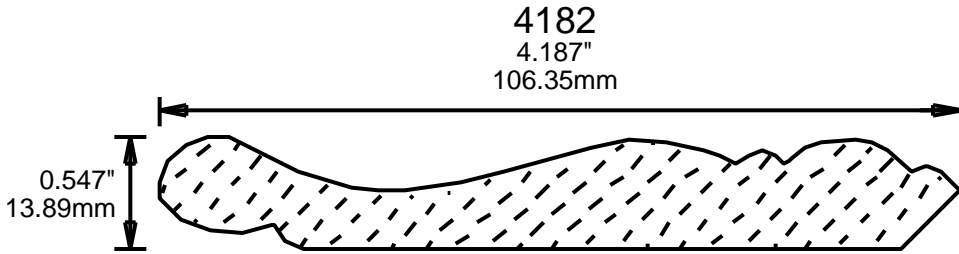
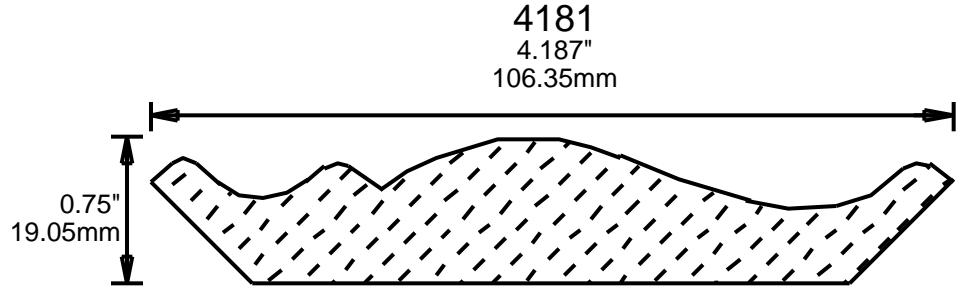
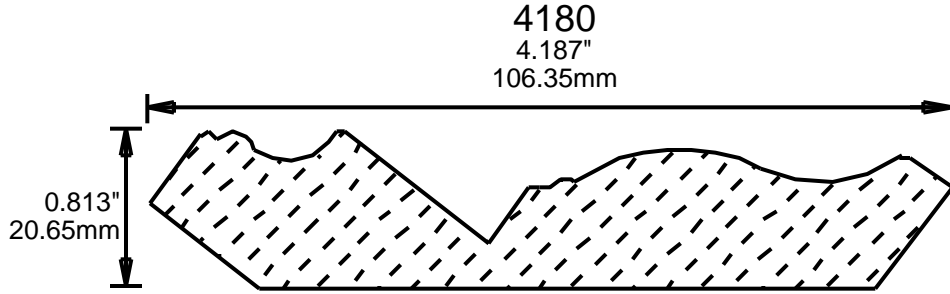

# WEINIG CROWN MOULDING PATTERNS

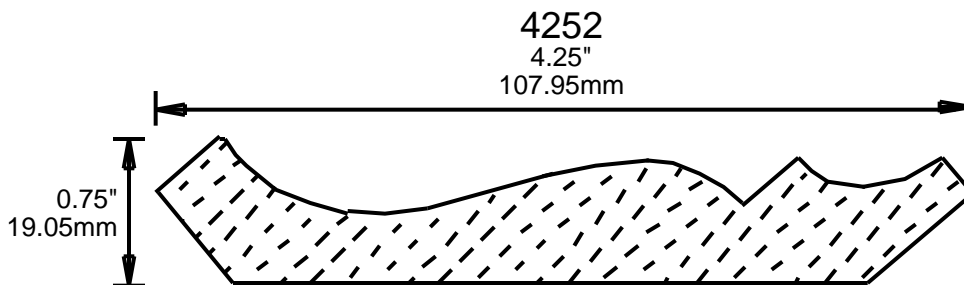
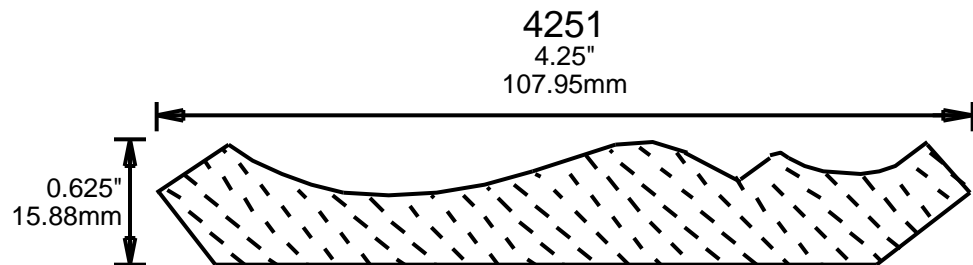
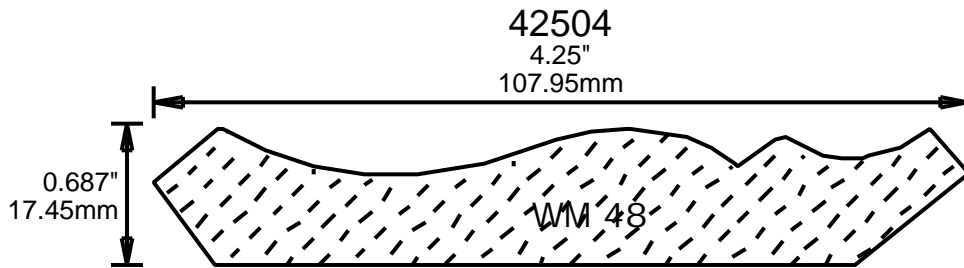
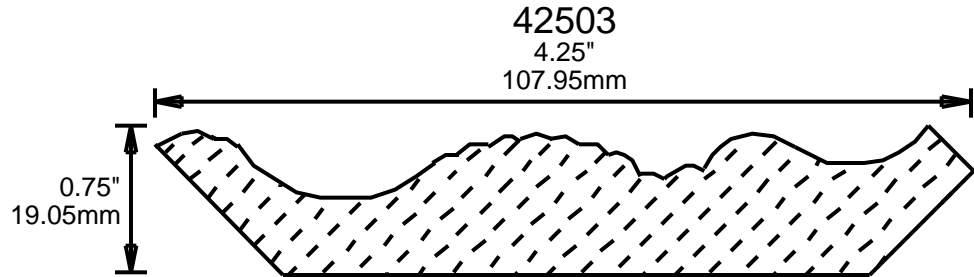
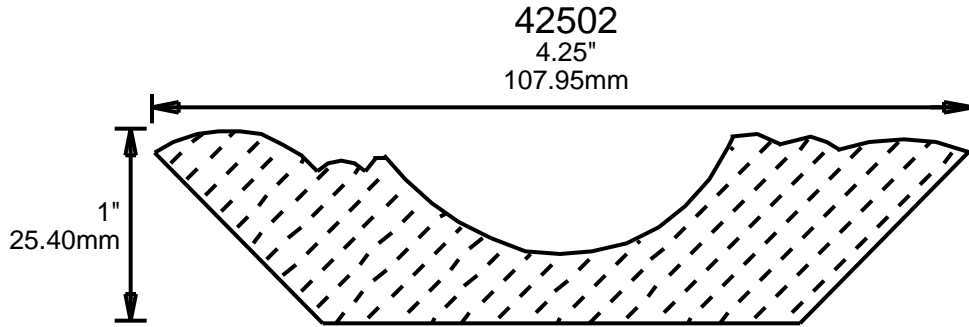

**PRINT  
THIS SECTION**

**RETURN TO  
Table of Contents**

# WEINIG CROWN MOULDING PATTERNS

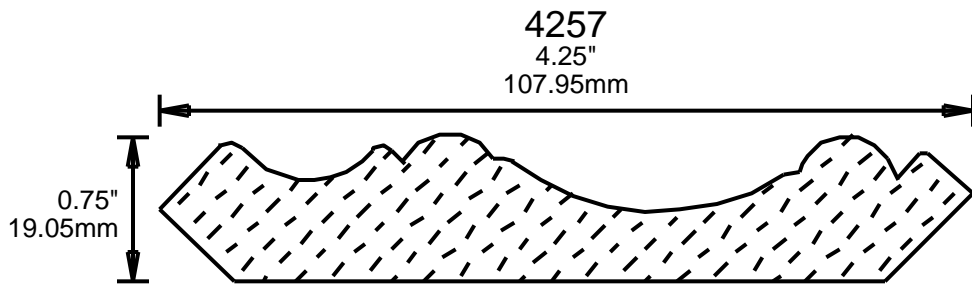
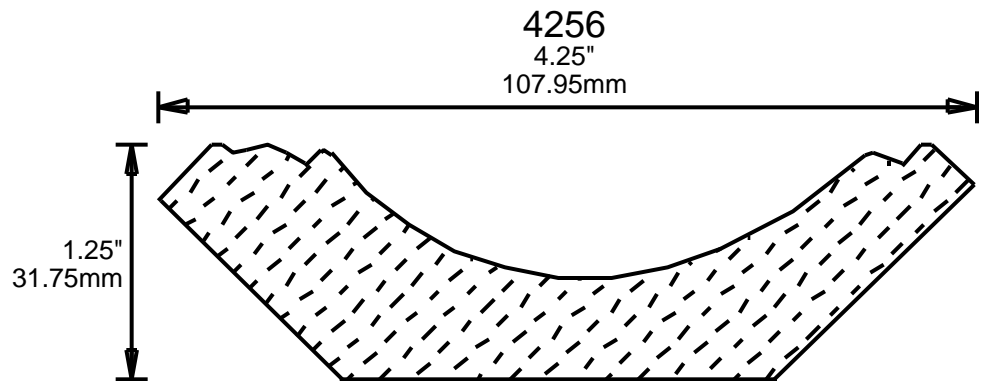
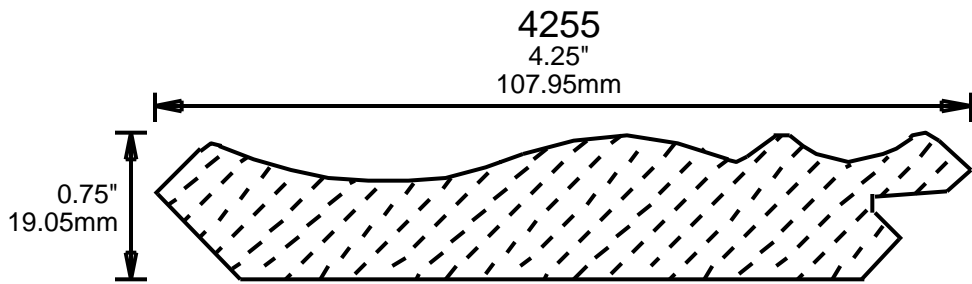
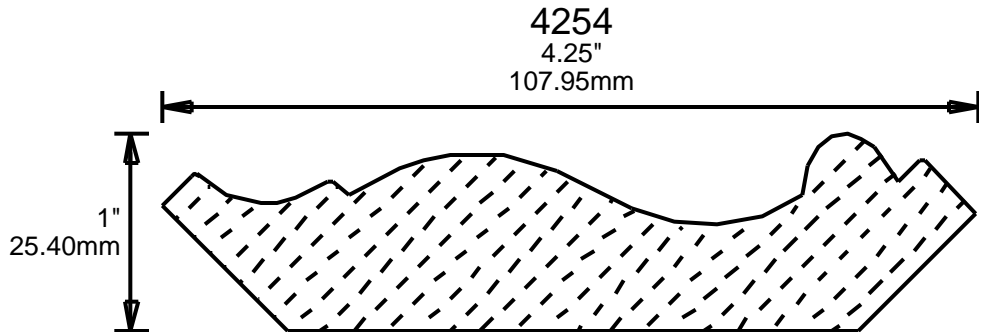
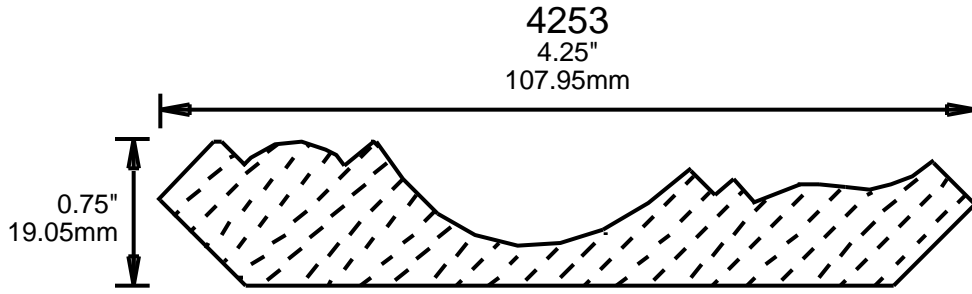



# WEINIG CROWN MOULDING PATTERNS

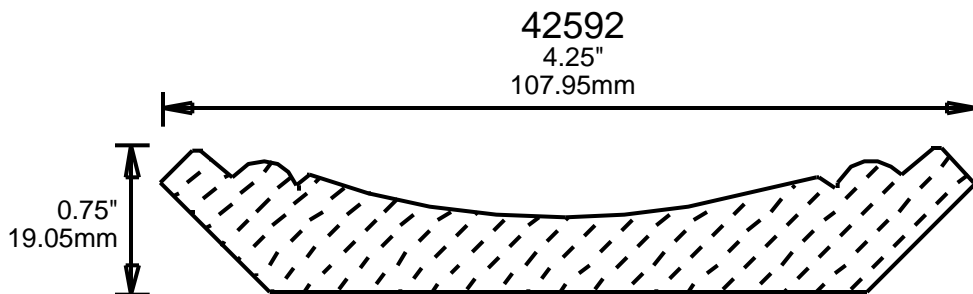
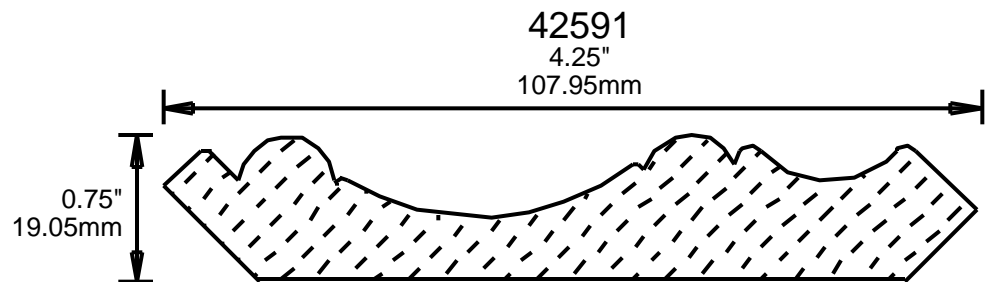
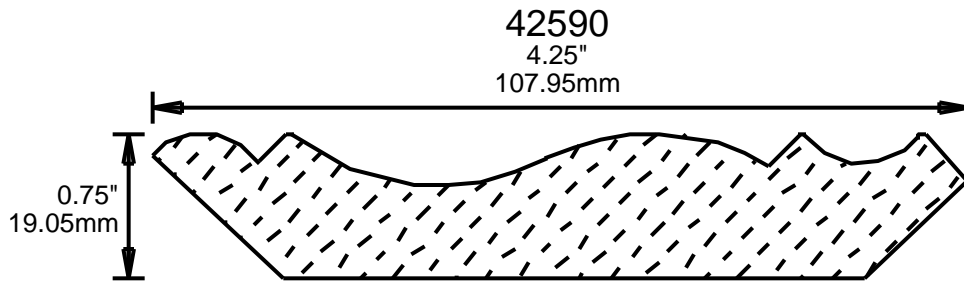
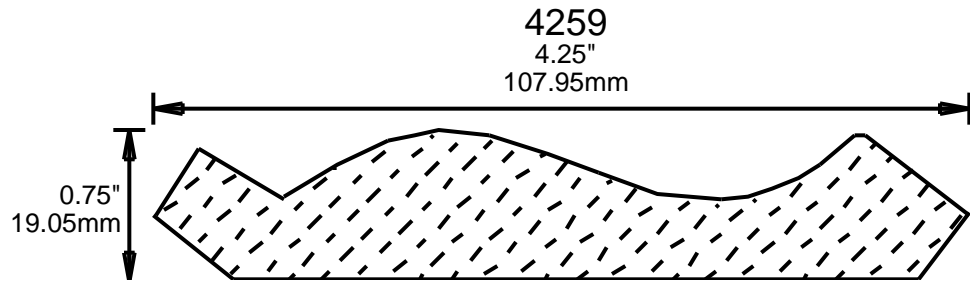
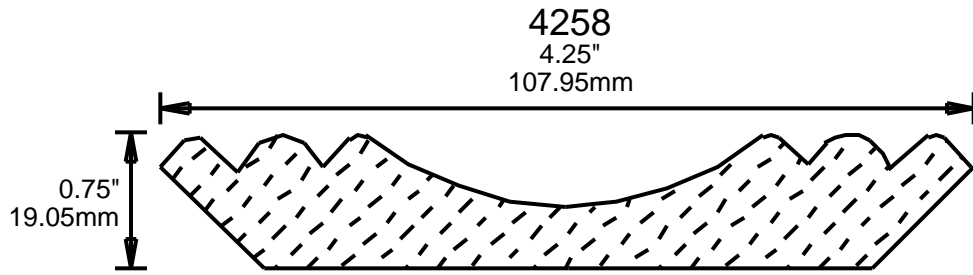

# WEINIG CROWN MOULDING PATTERNS

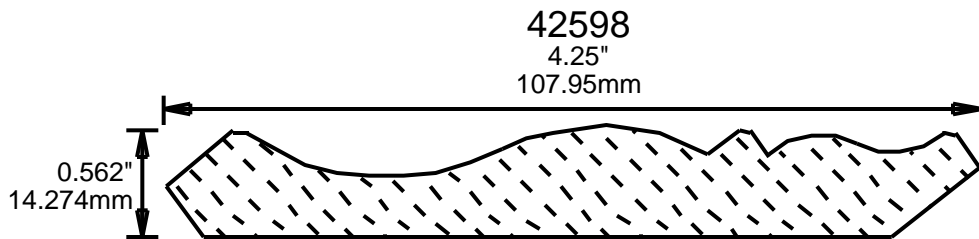
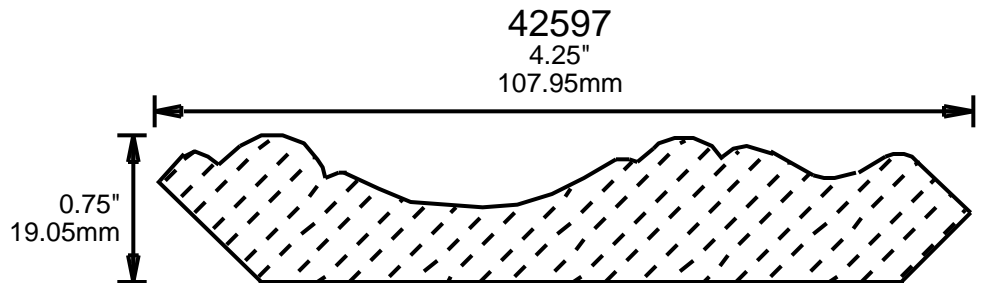
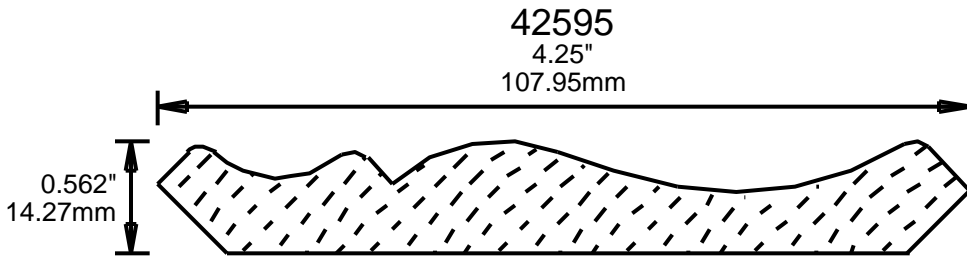
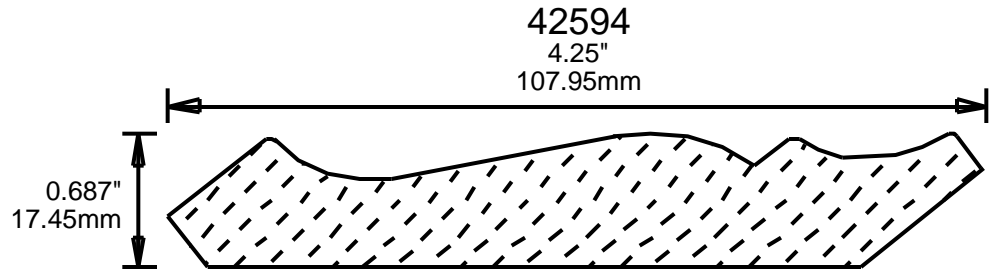
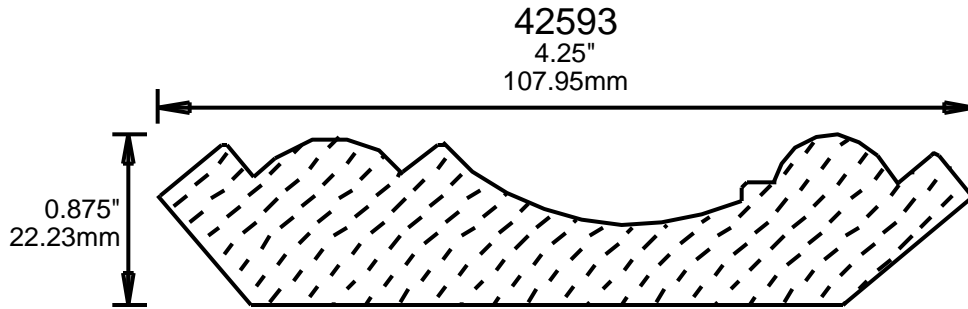

# WEINIG CROWN MOULDING PATTERNS

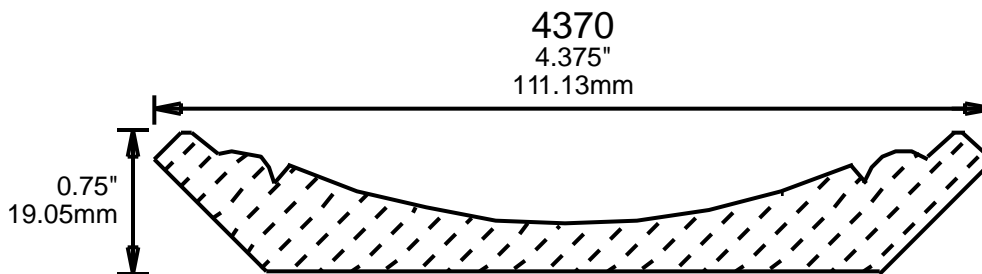
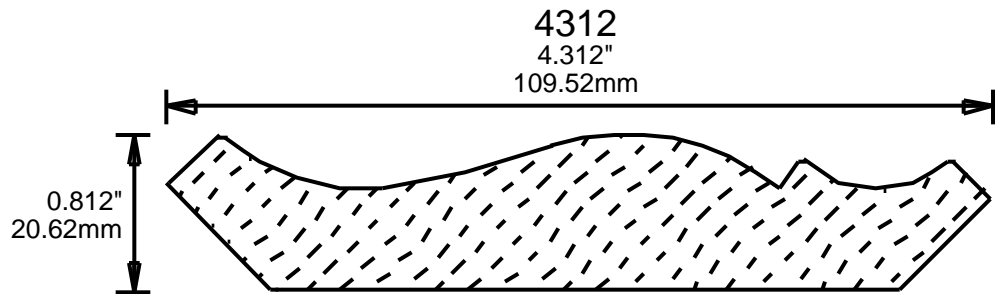
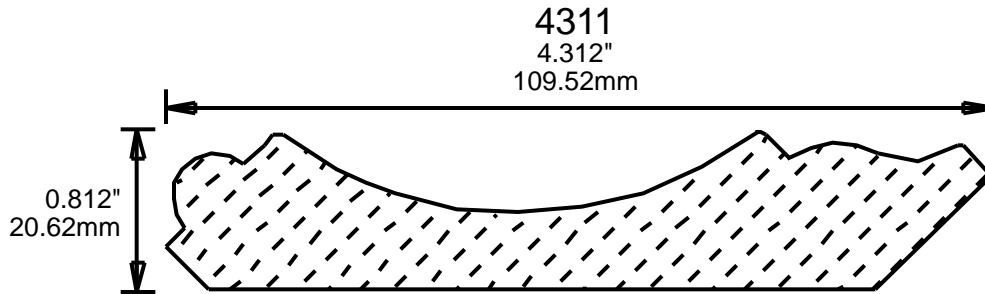
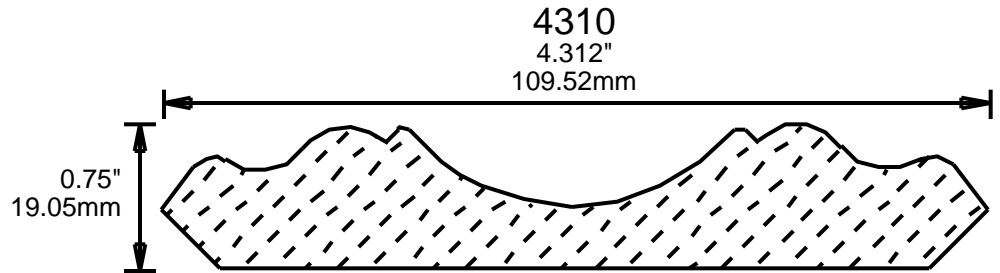
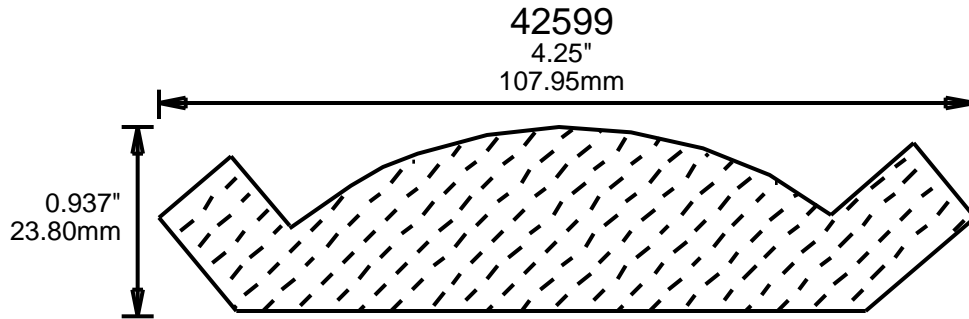

# WEINIG CROWN MOULDING PATTERNS

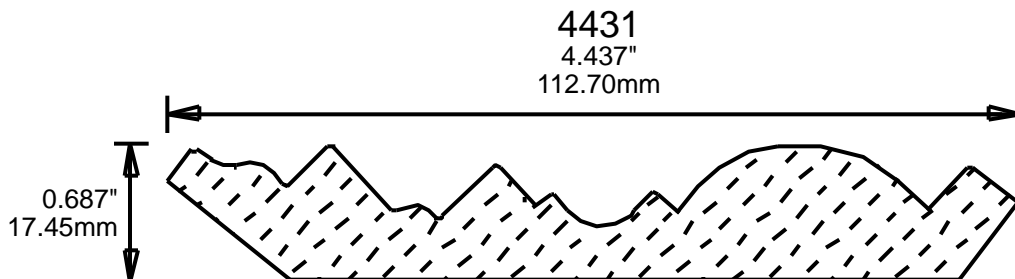
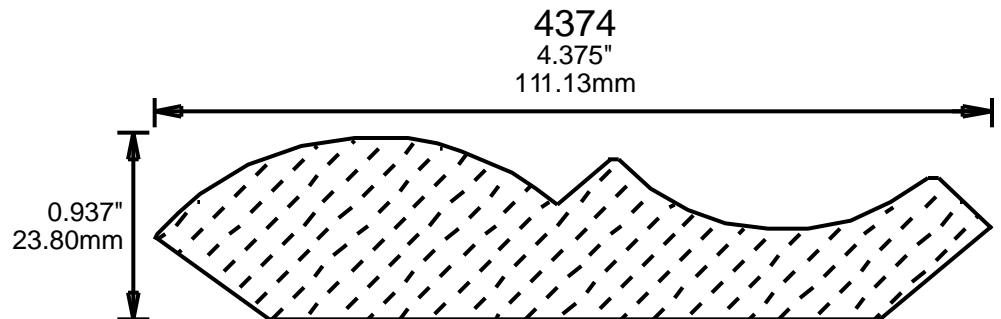
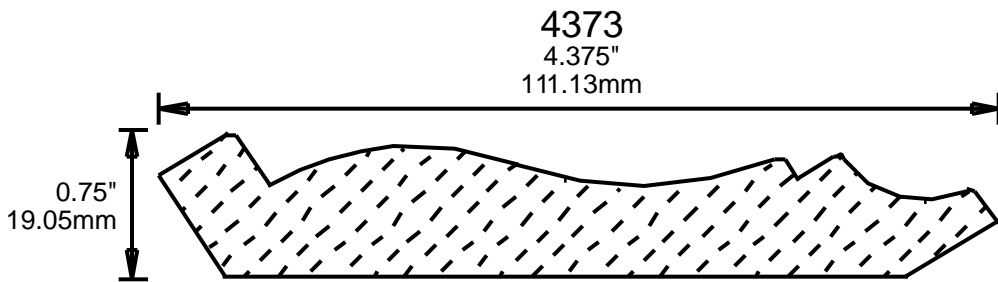
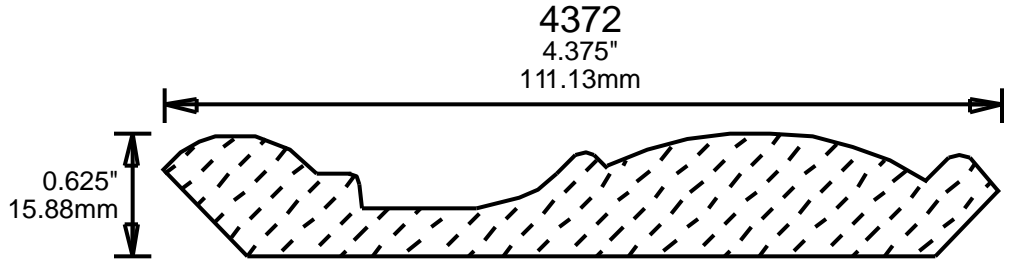
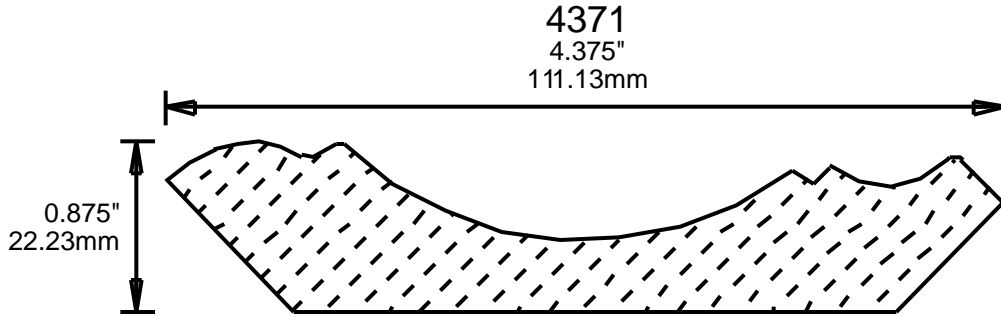

# WEINIG CROWN MOULDING PATTERNS

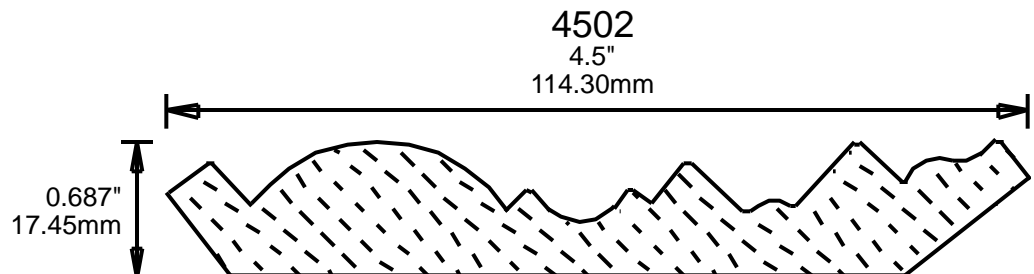
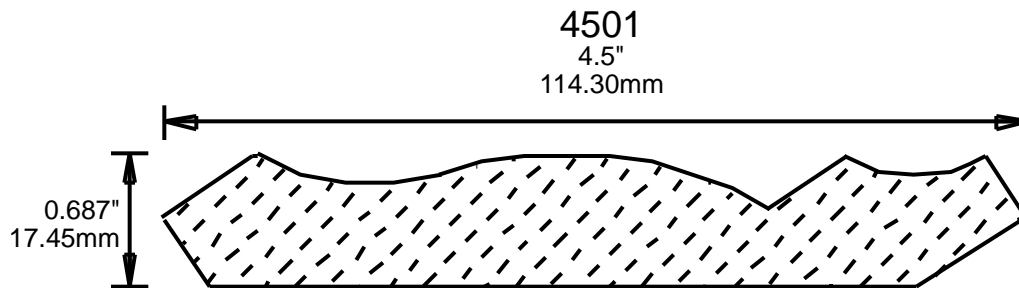
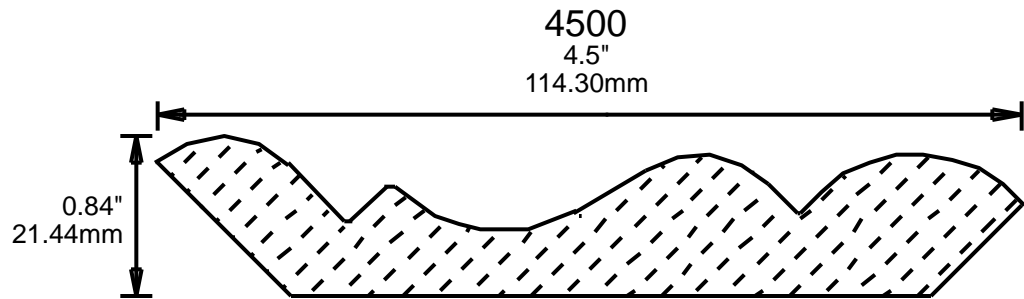
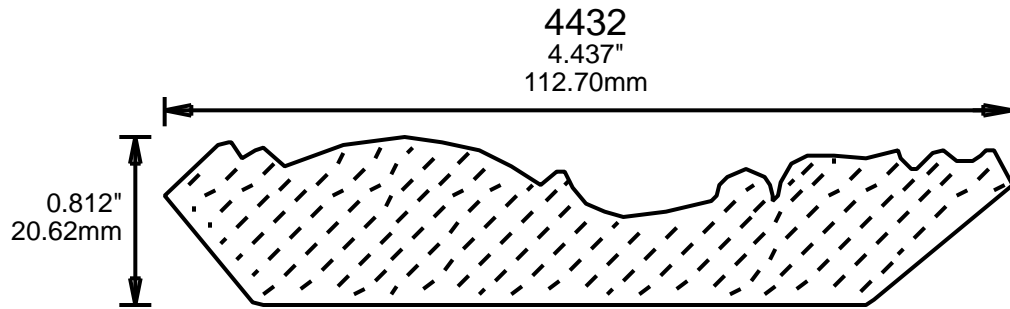

# WEINIG CROWN MOULDING PATTERNS

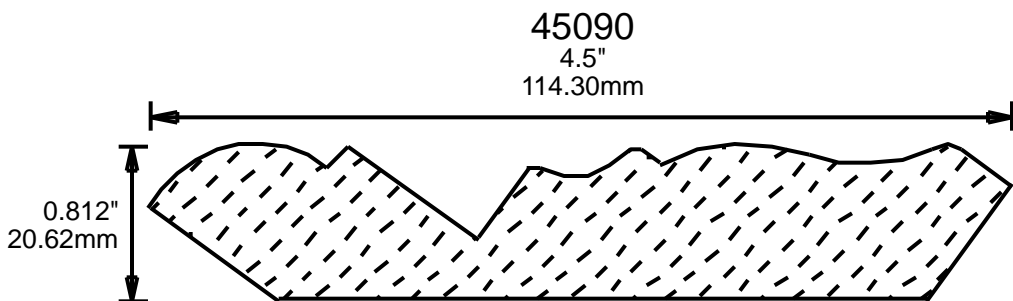
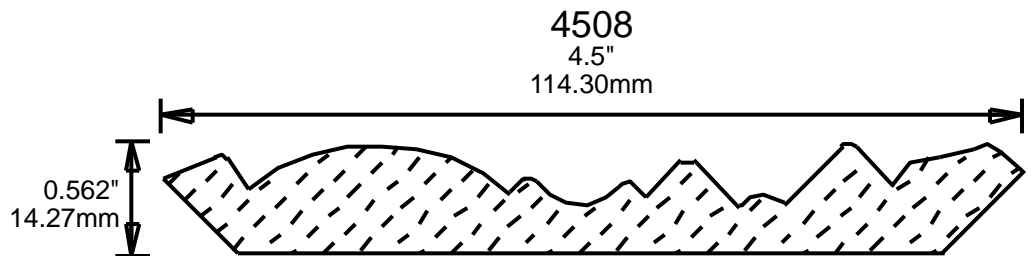
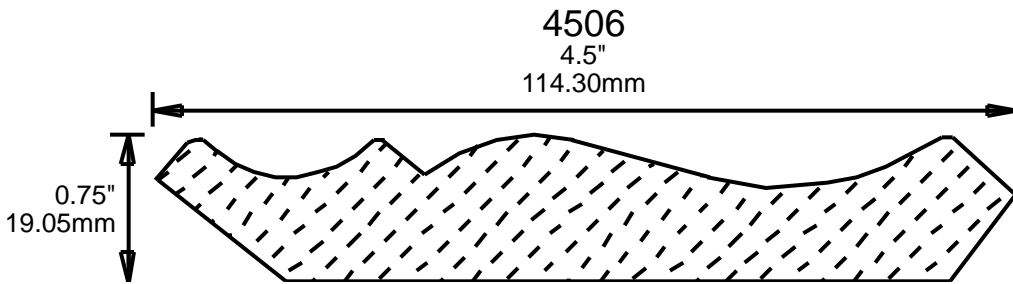
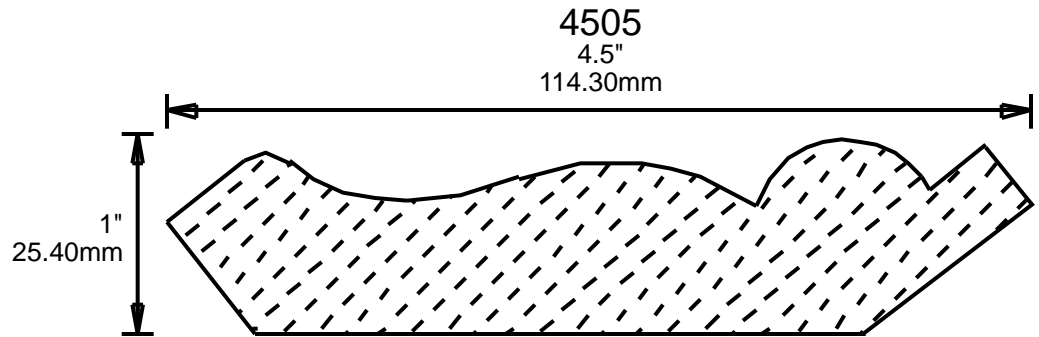
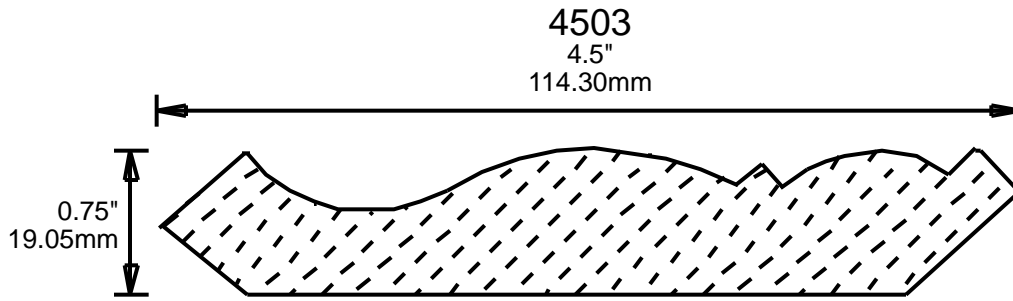

# WEINIG CROWN MOULDING PATTERNS

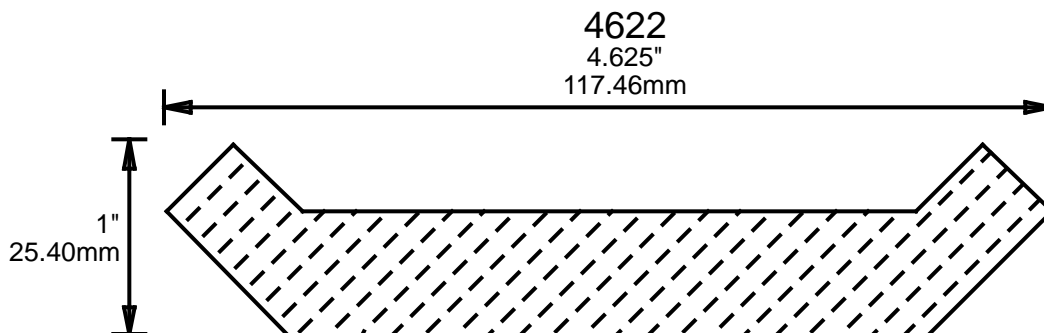
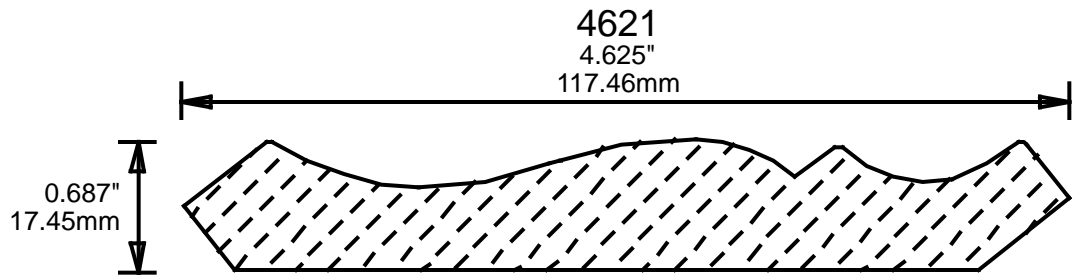
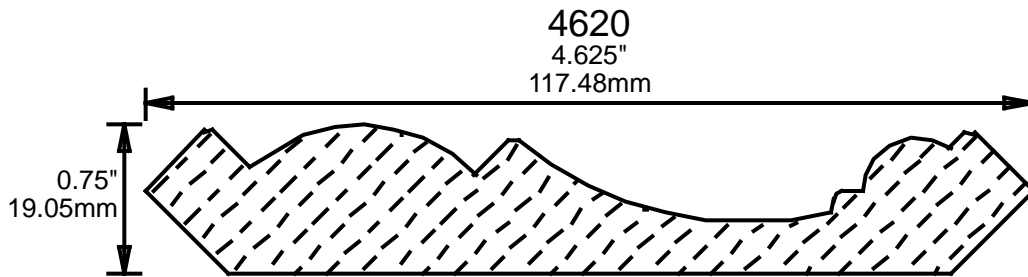
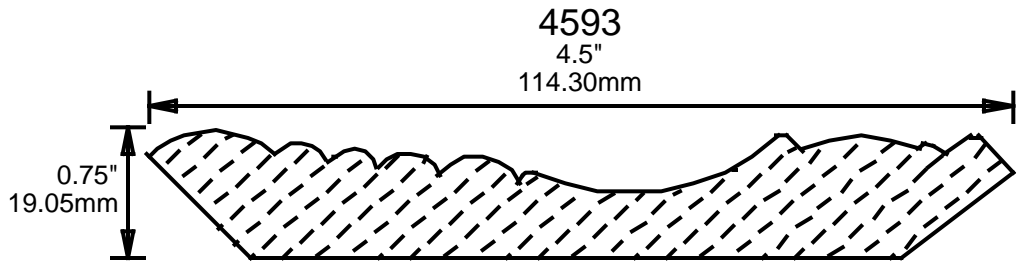
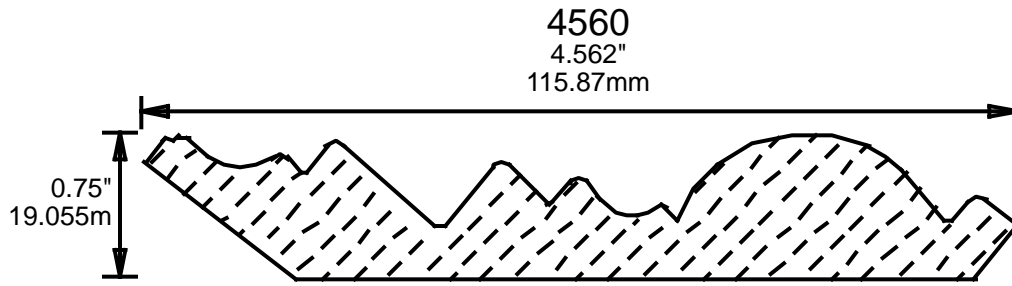

# WEINIG CROWN MOULDING PATTERNS

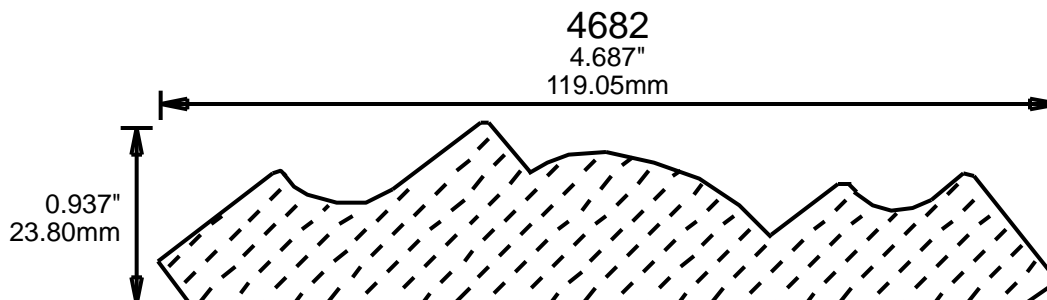
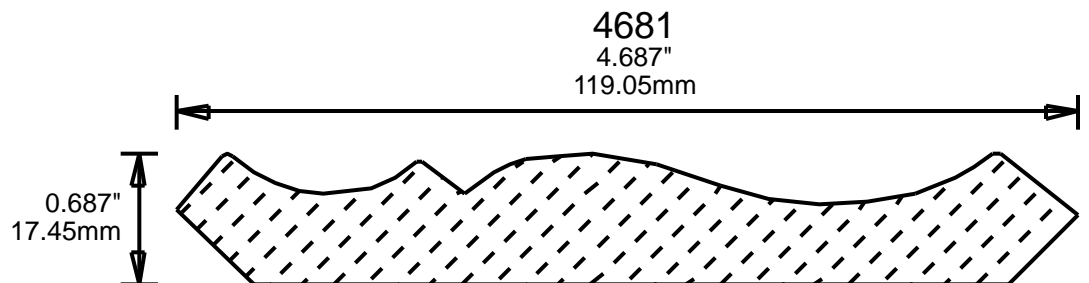
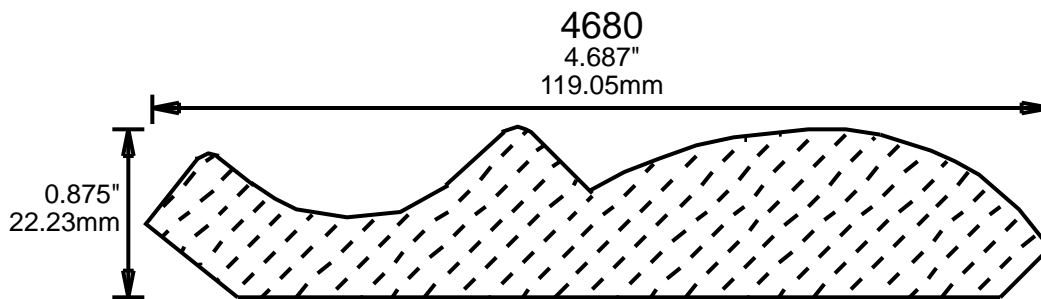
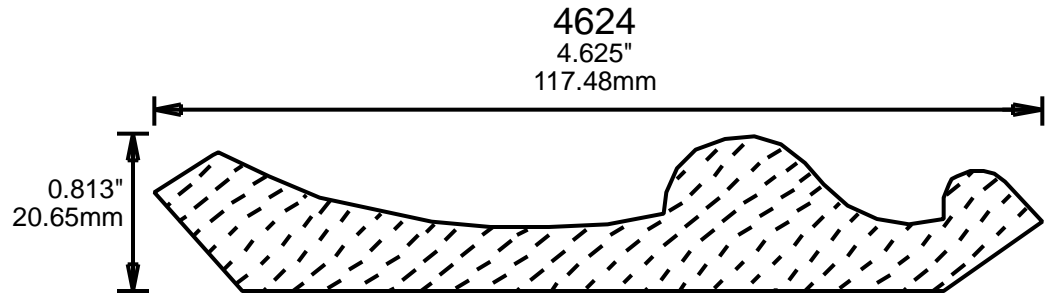
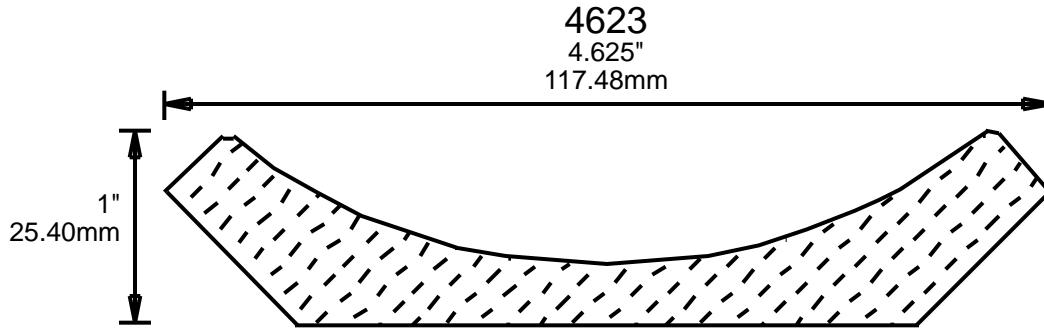



# WEINIG CROWN MOULDING PATTERNS

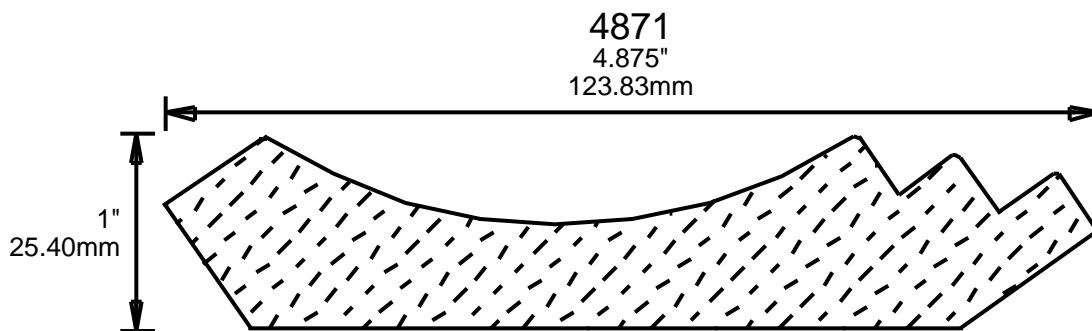
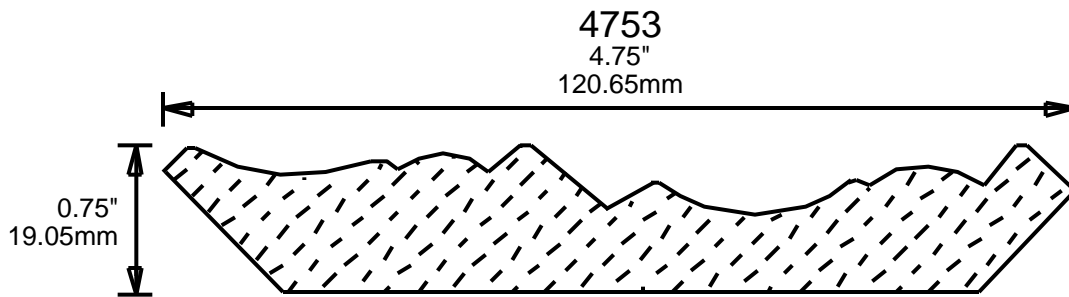
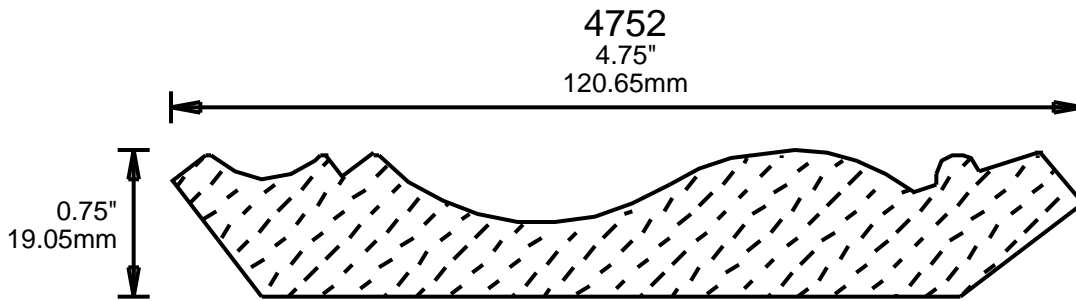
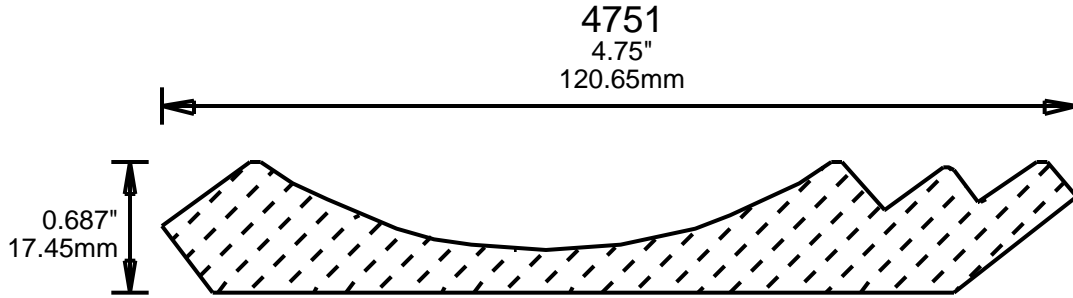
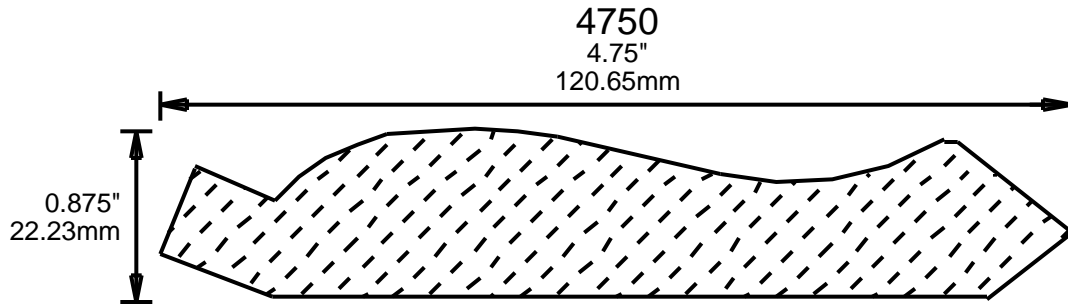

# WEINIG CROWN MOULDING PATTERNS

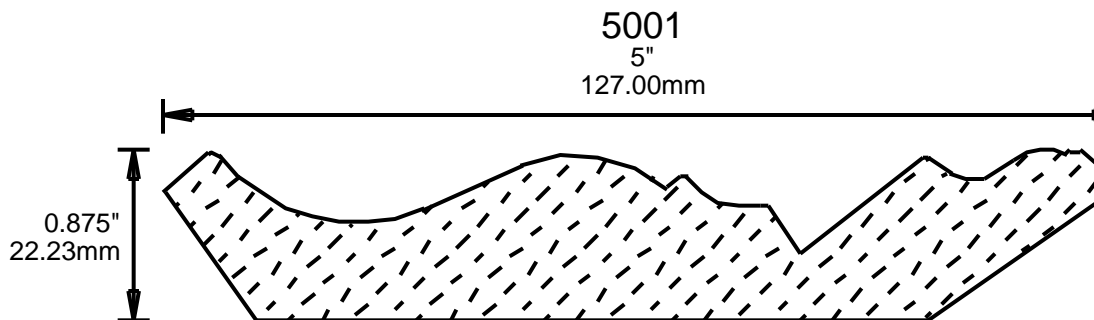
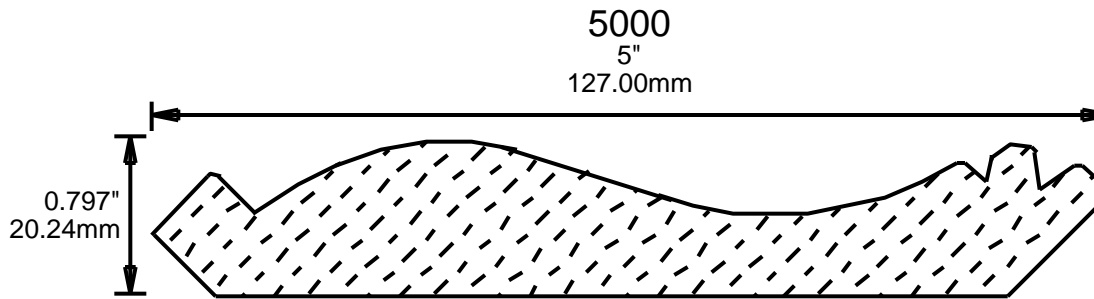
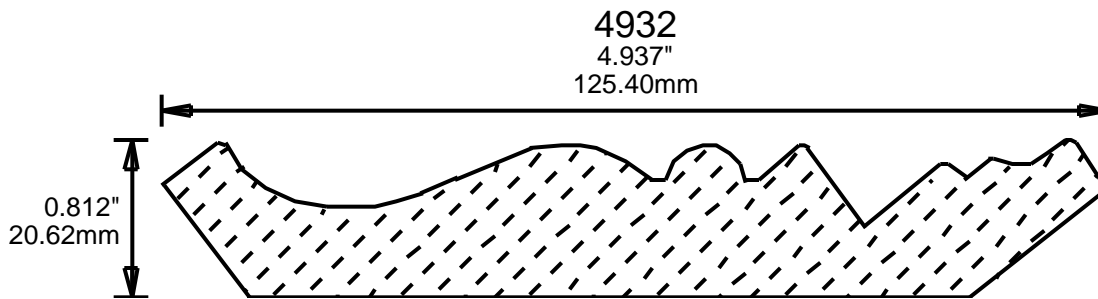
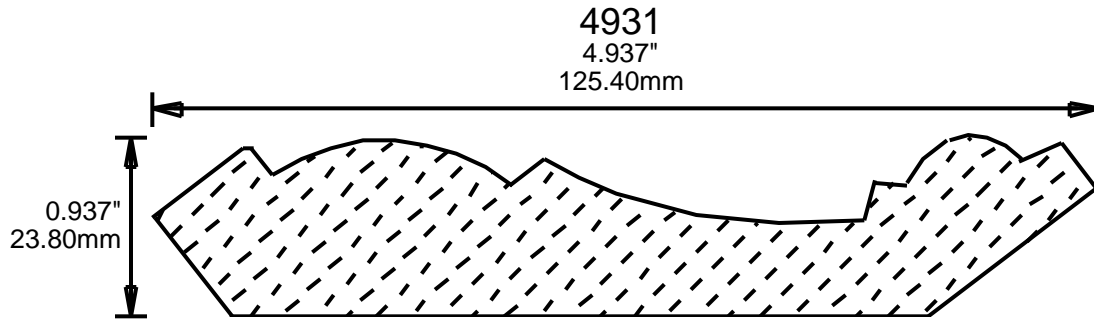
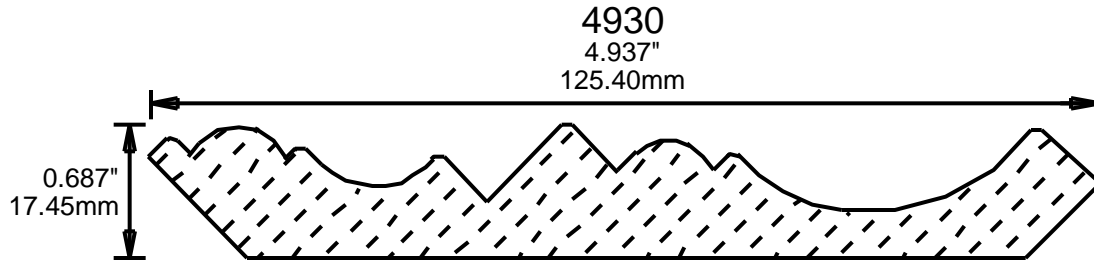

# WEINIG CROWN MOULDING PATTERNS

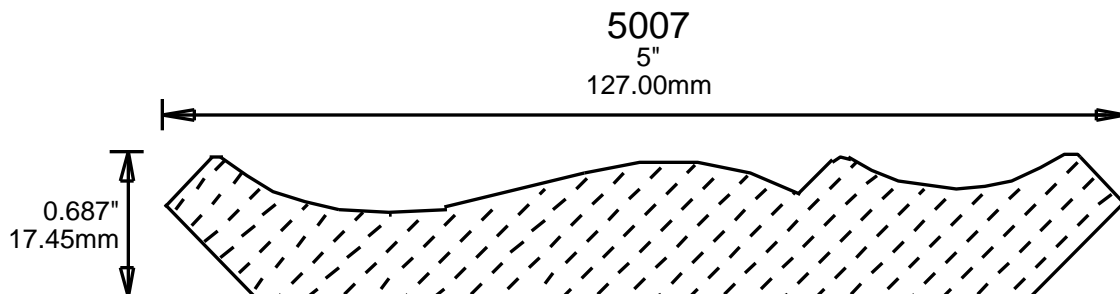
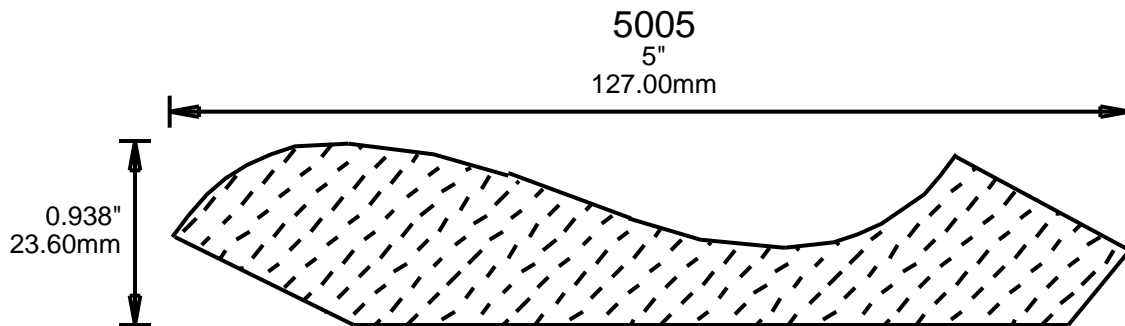
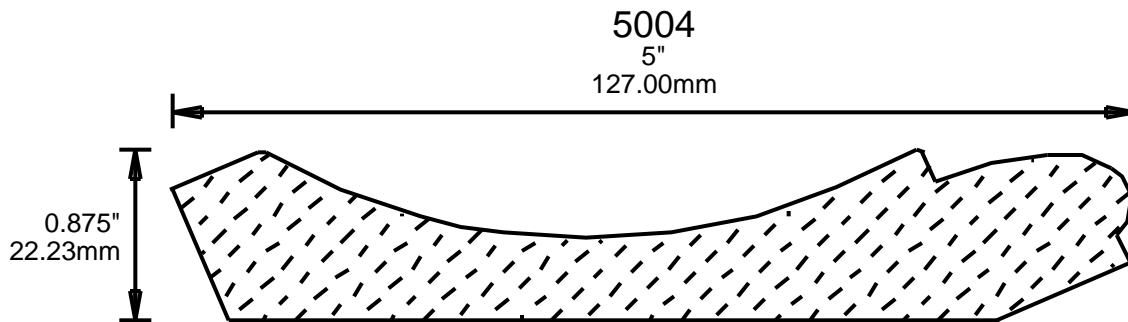
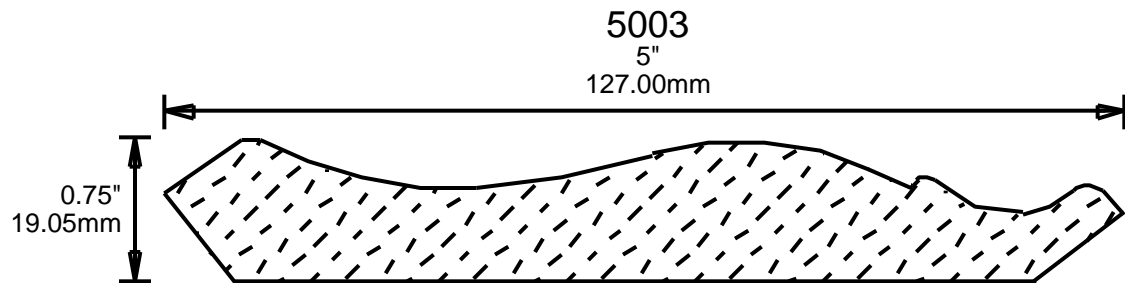
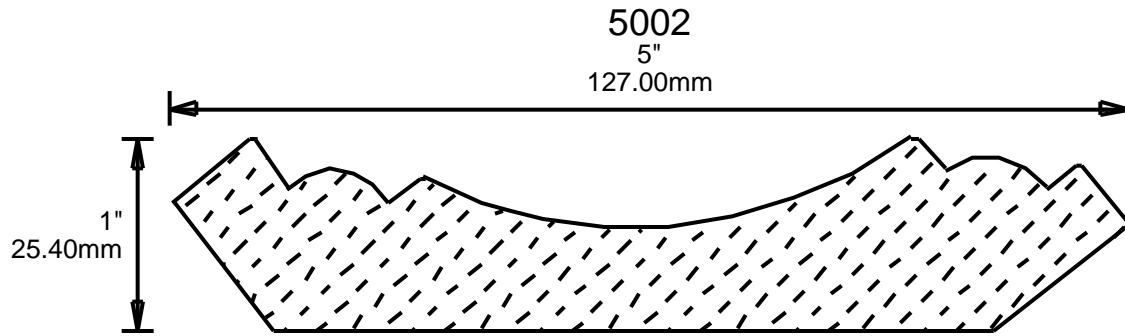

**PRINT  
THIS SECTION**

**RETURN TO  
Table of Contents**

# WEINIG CROWN MOULDING PATTERNS

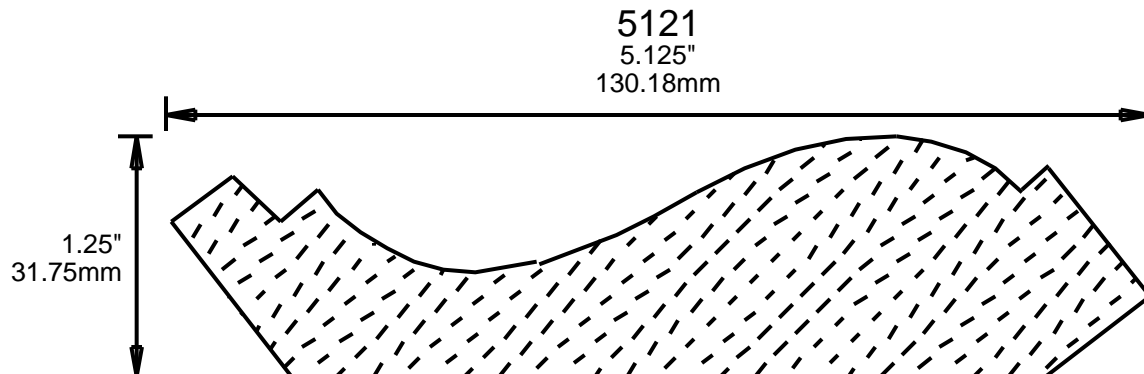
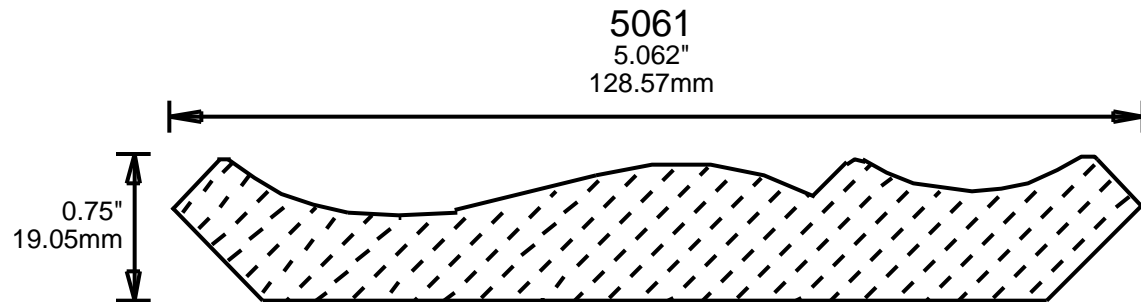
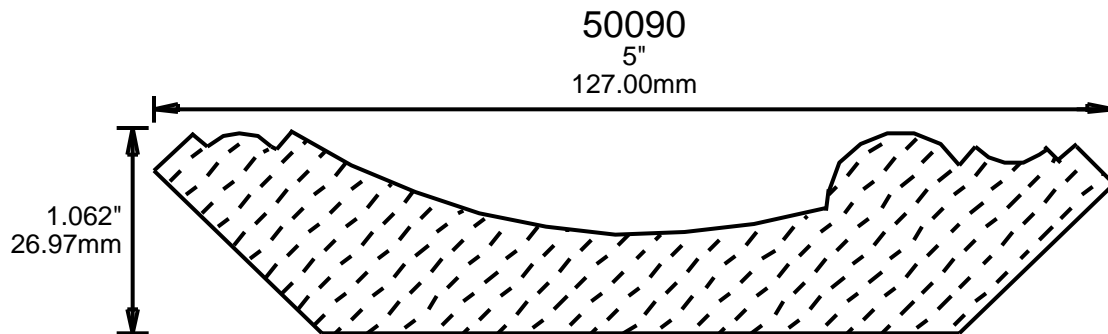
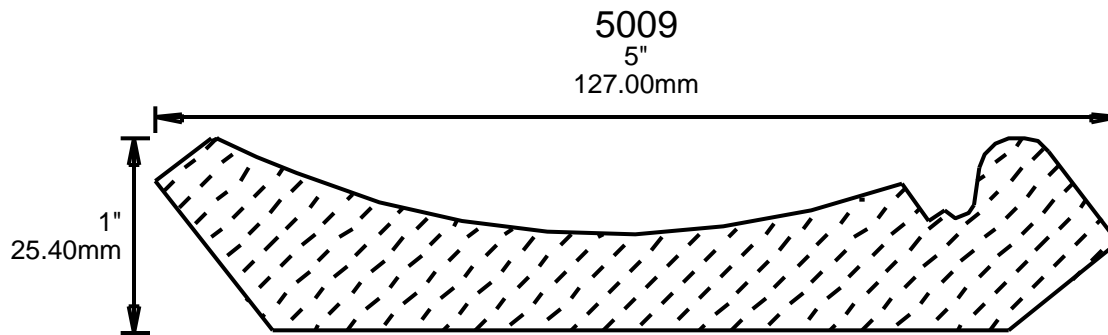
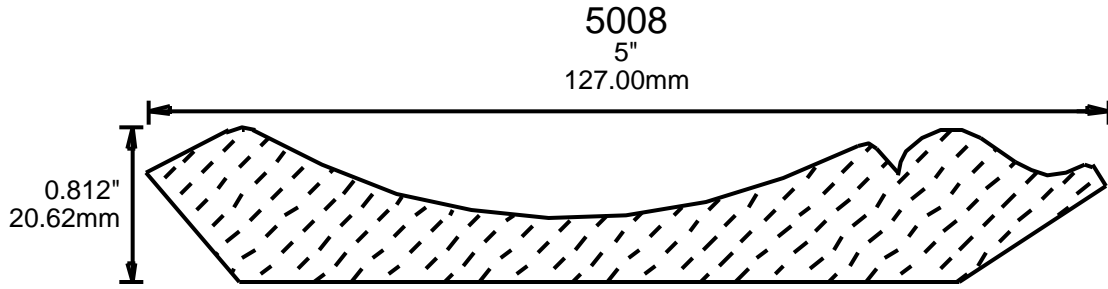

# WEINIG CROWN MOULDING PATTERNS

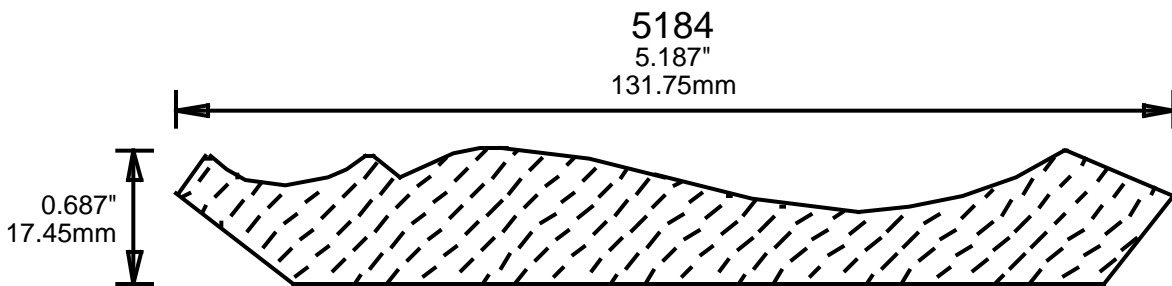
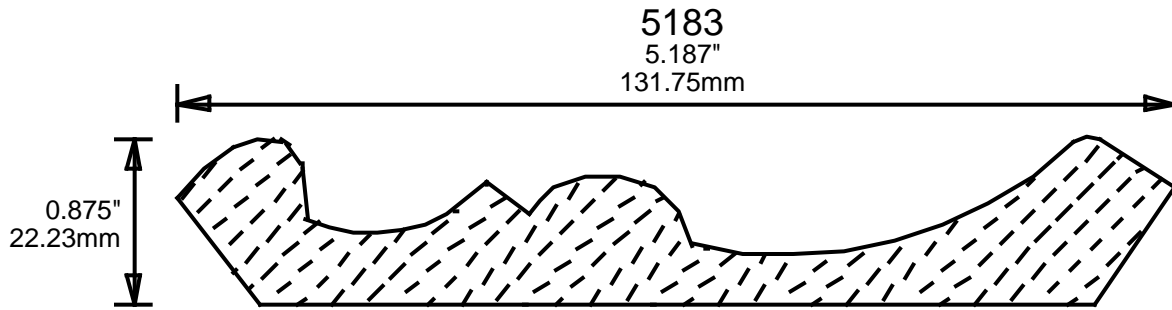
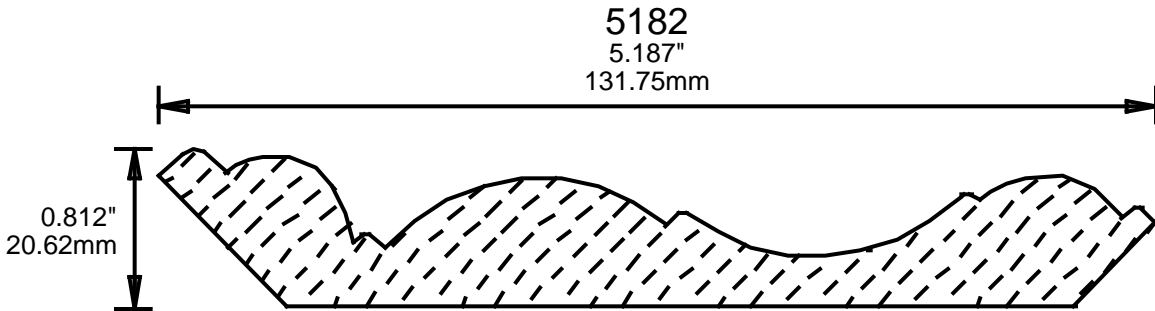
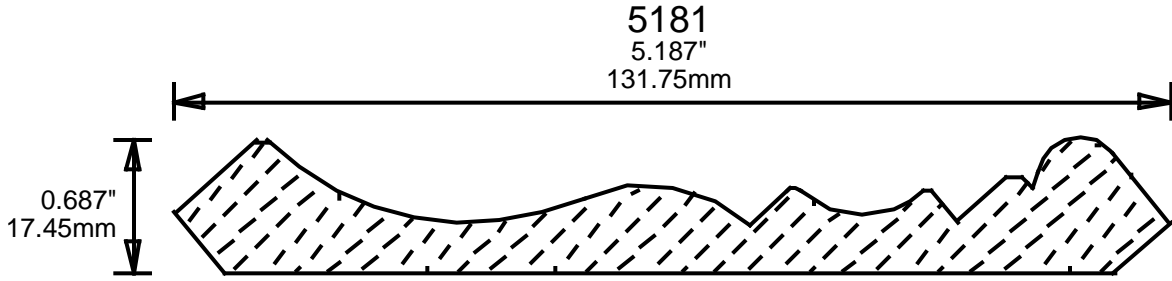

# WEINIG CROWN MOULDING PATTERNS

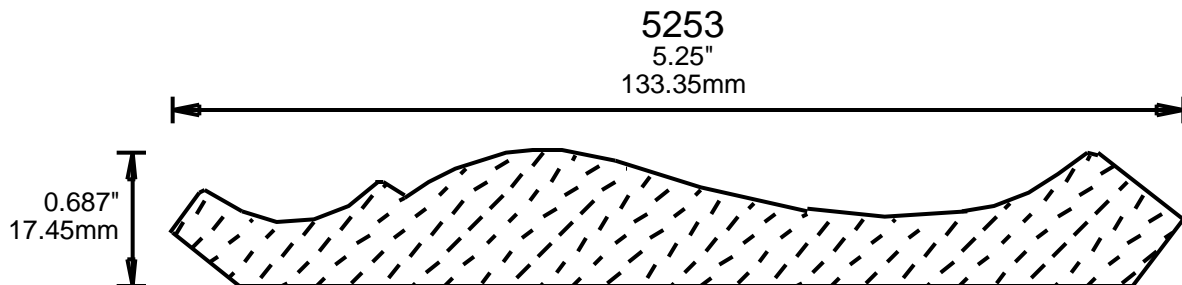
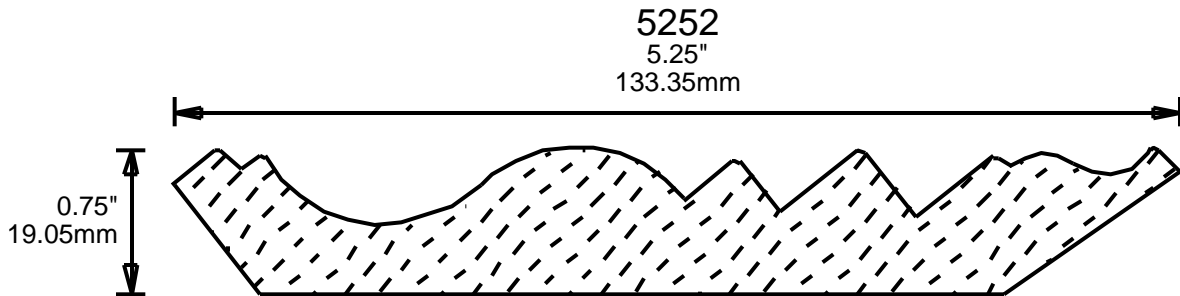
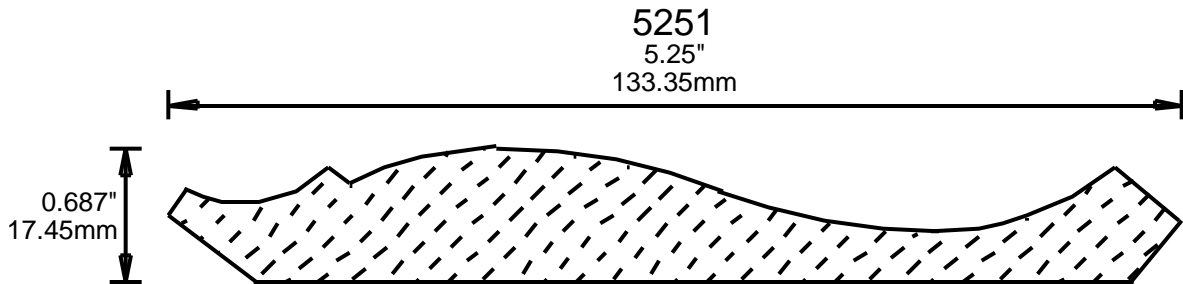
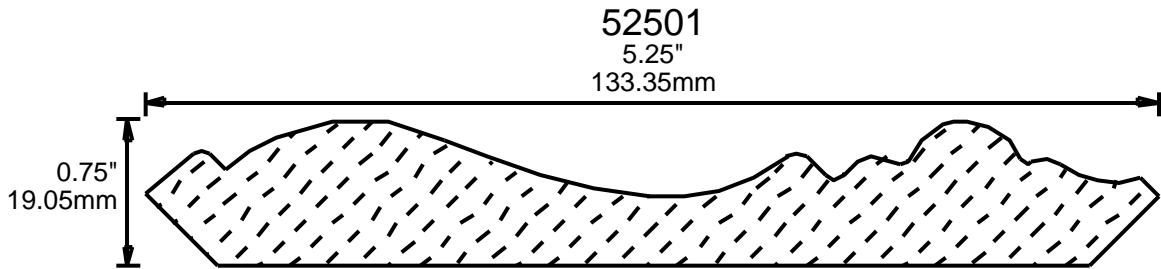
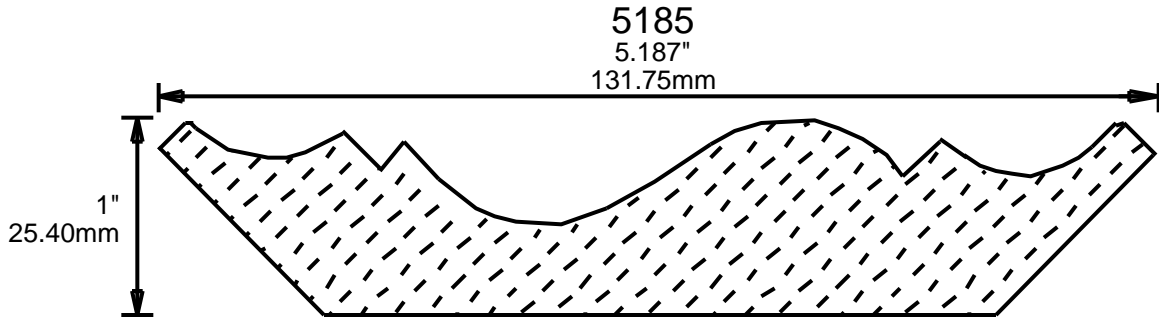

# WEINIG CROWN MOULDING PATTERNS

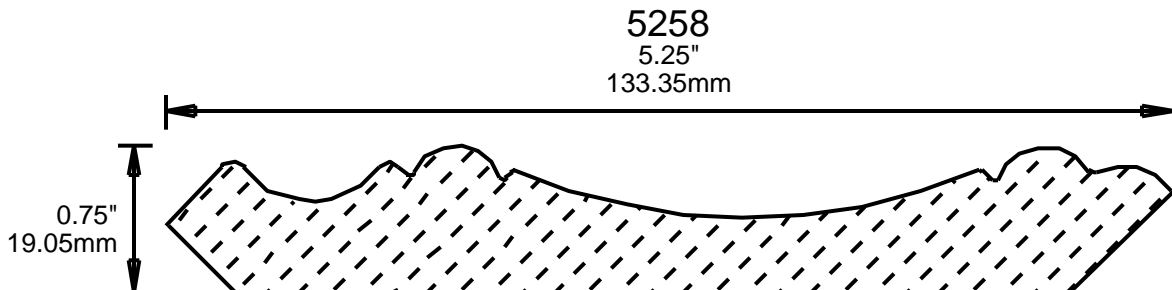
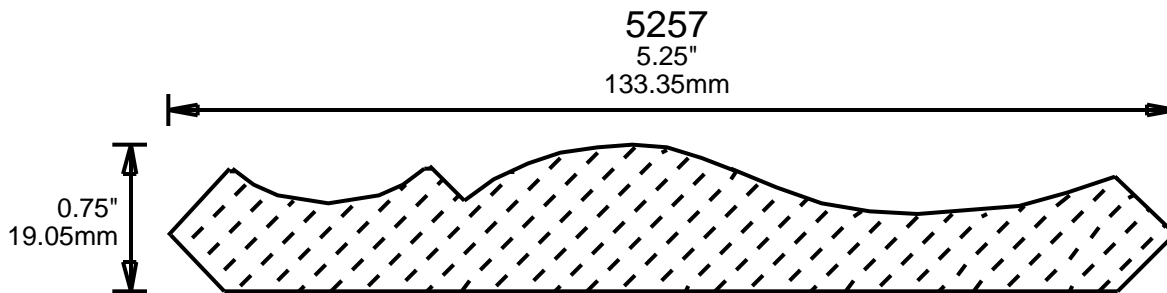
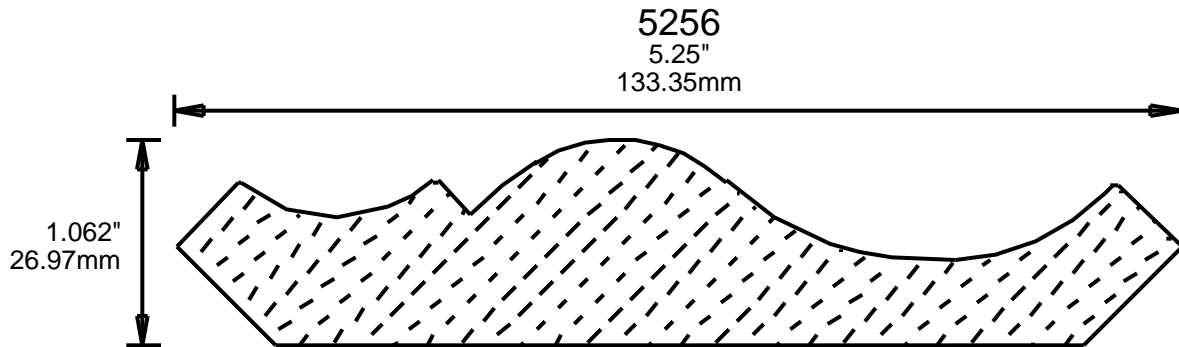
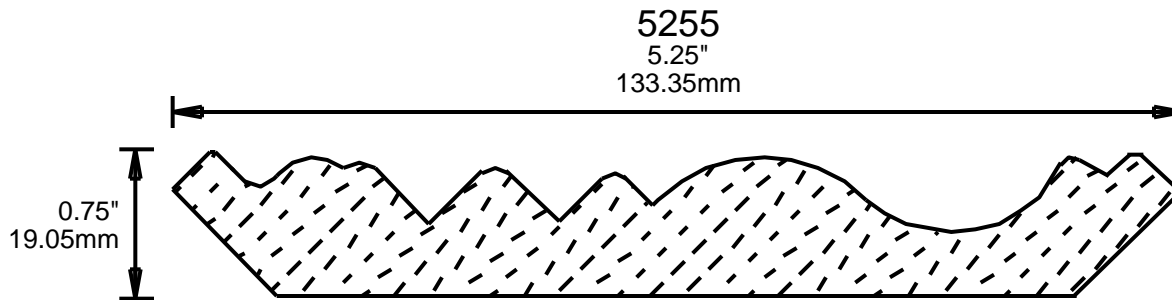
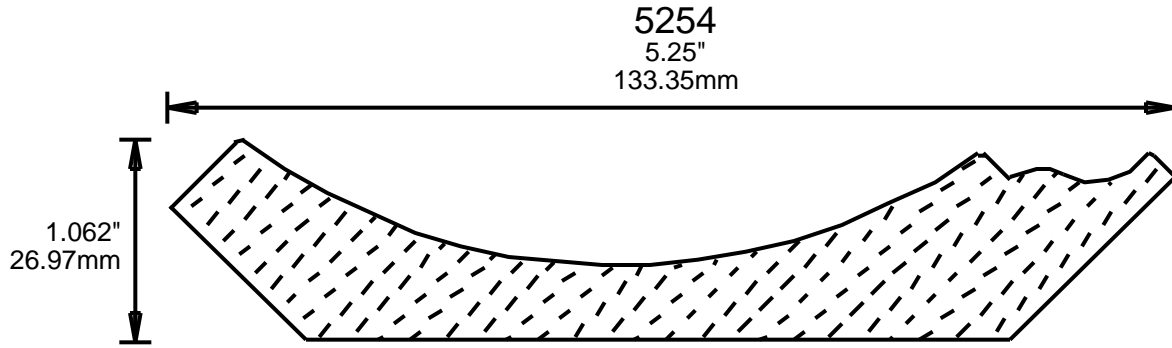

# WEINIG CROWN MOULDING PATTERNS

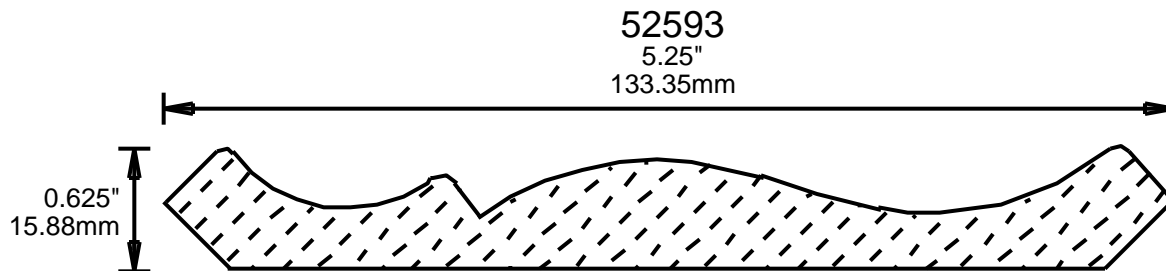
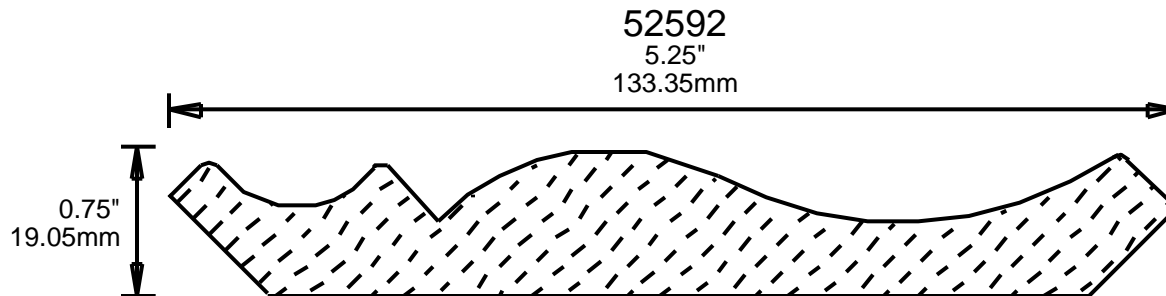
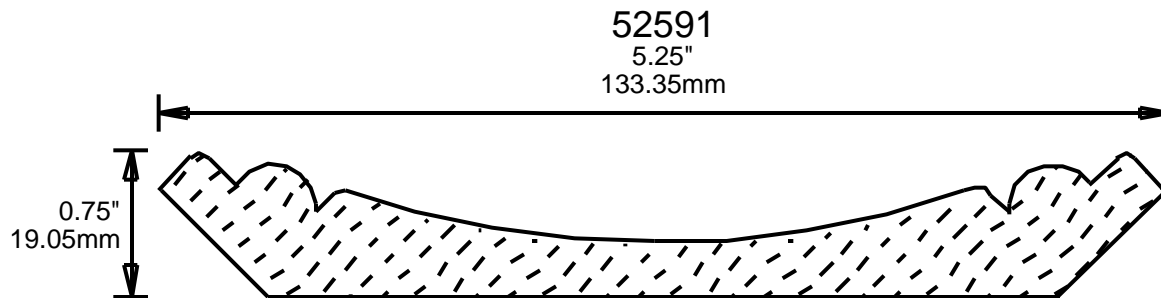
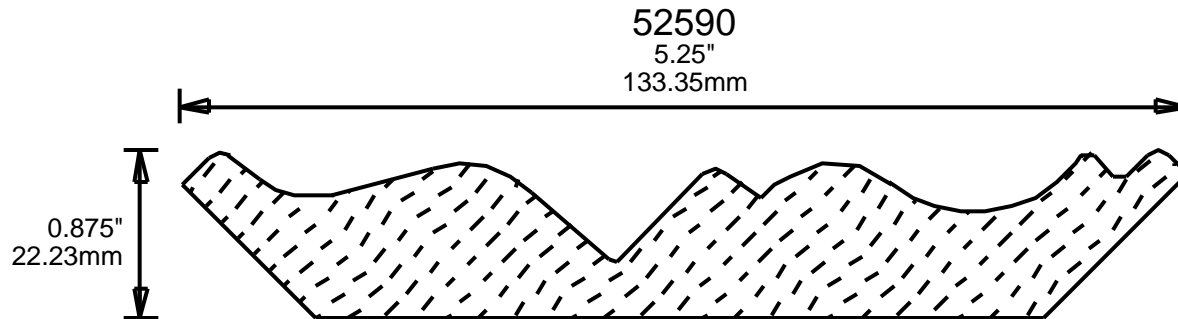
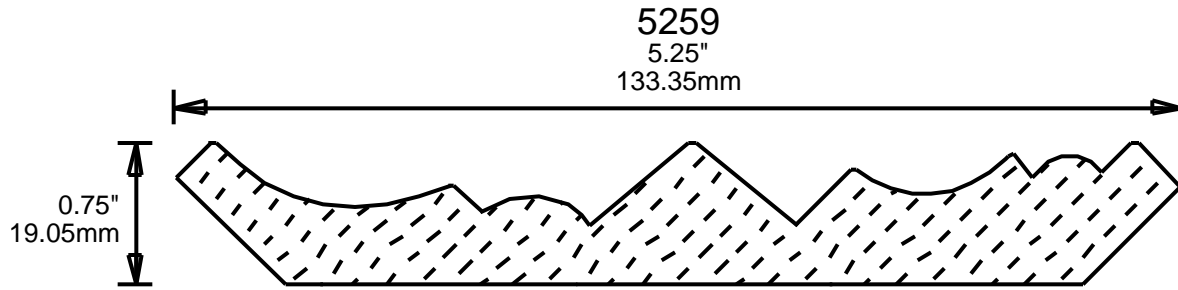



# WEINIG CROWN MOULDING PATTERNS

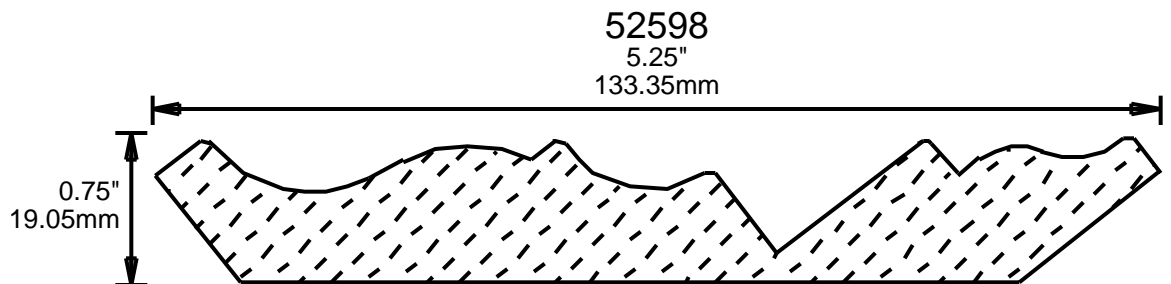
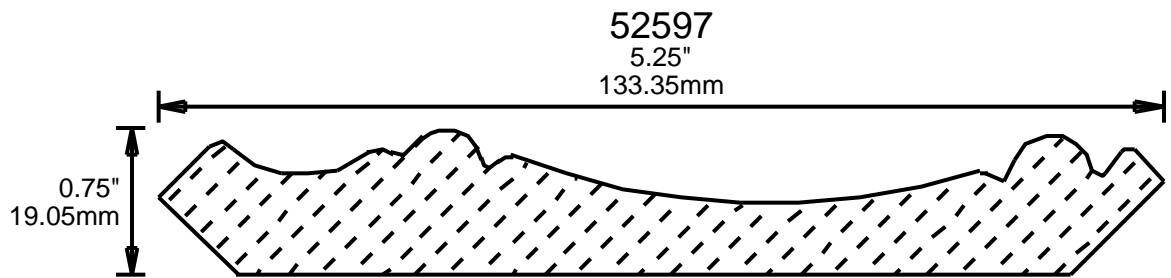
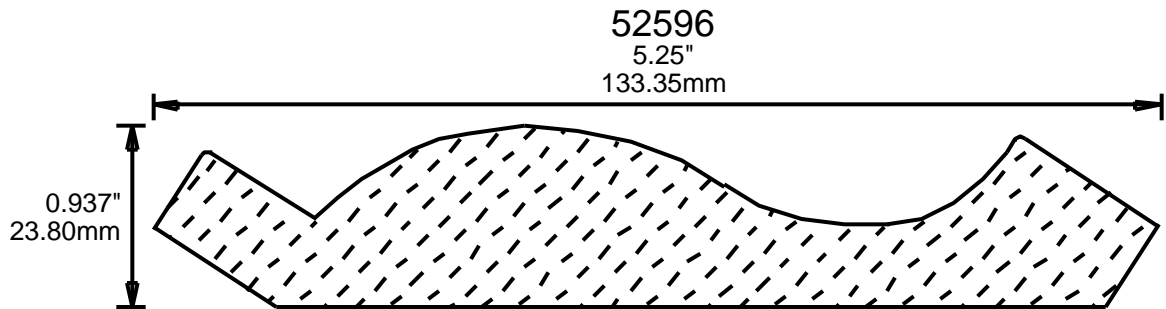
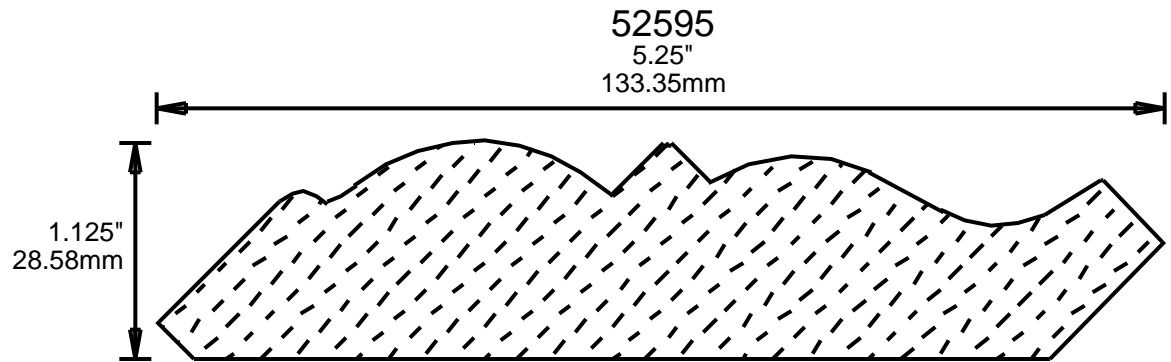
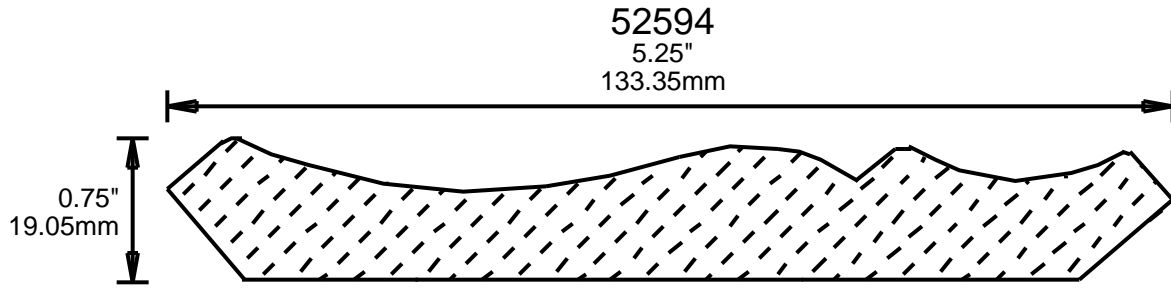

# WEINIG CROWN MOULDING PATTERNS

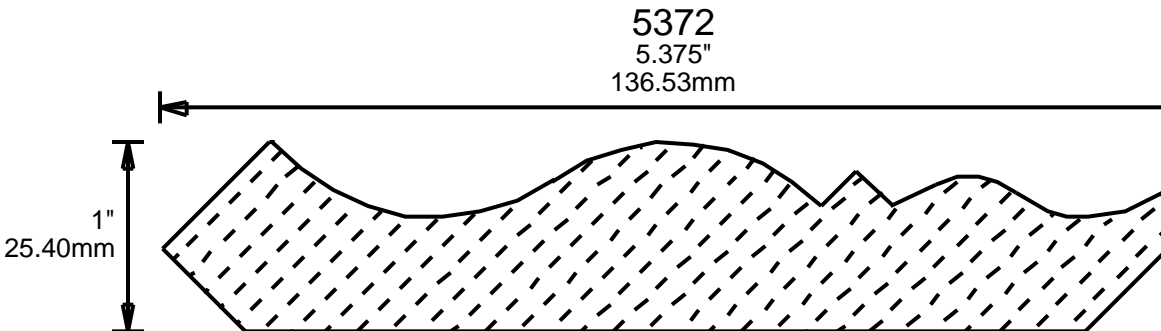
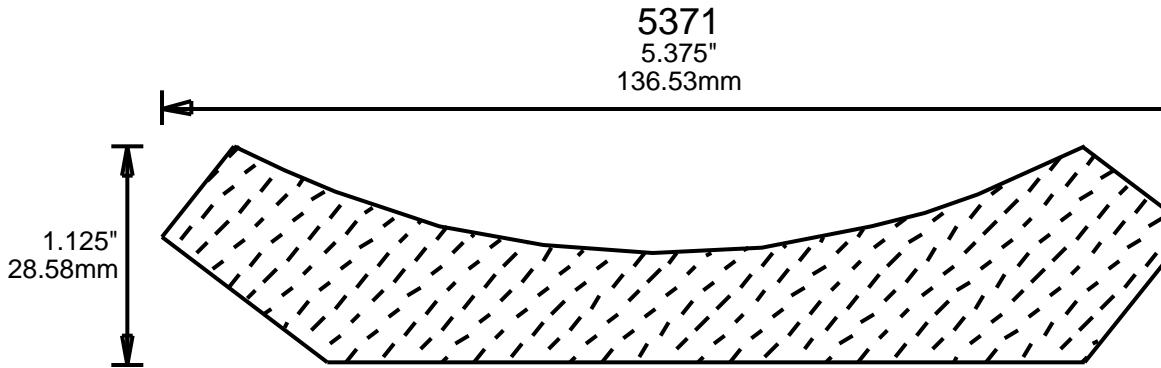
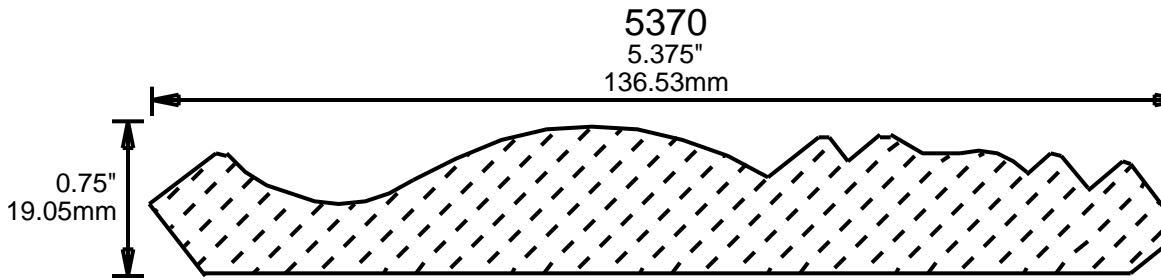
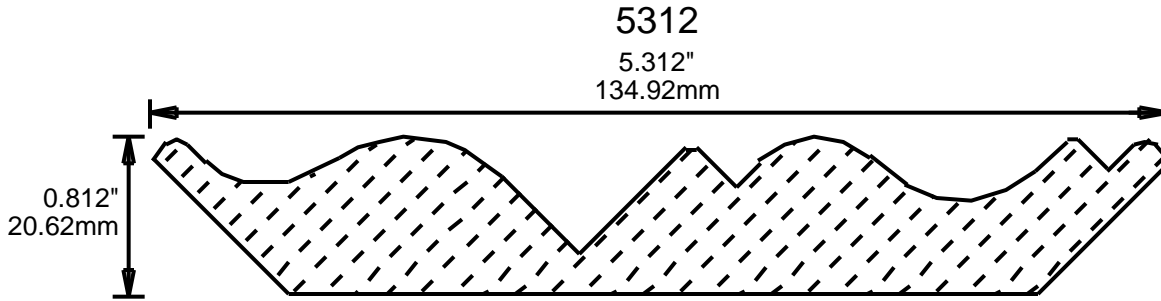
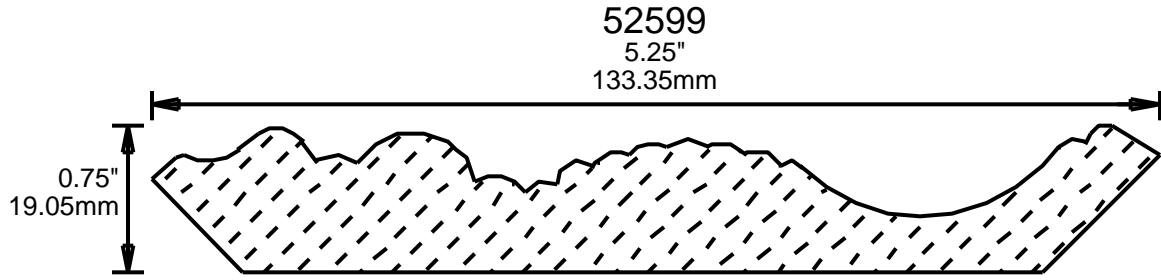

# WEINIG CROWN MOULDING PATTERNS

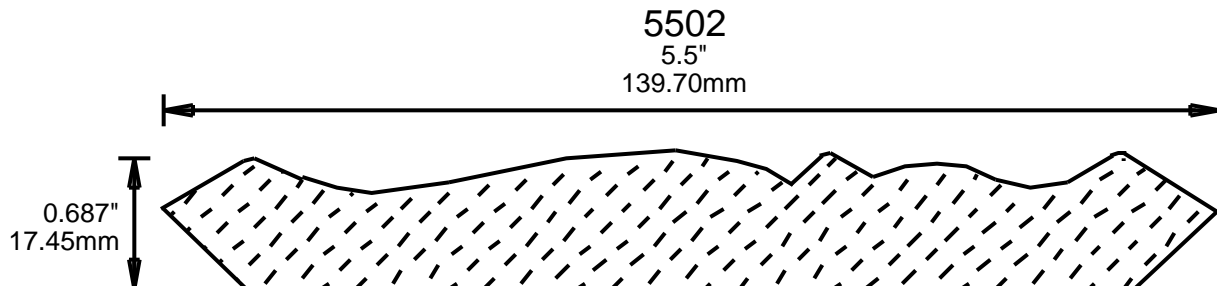
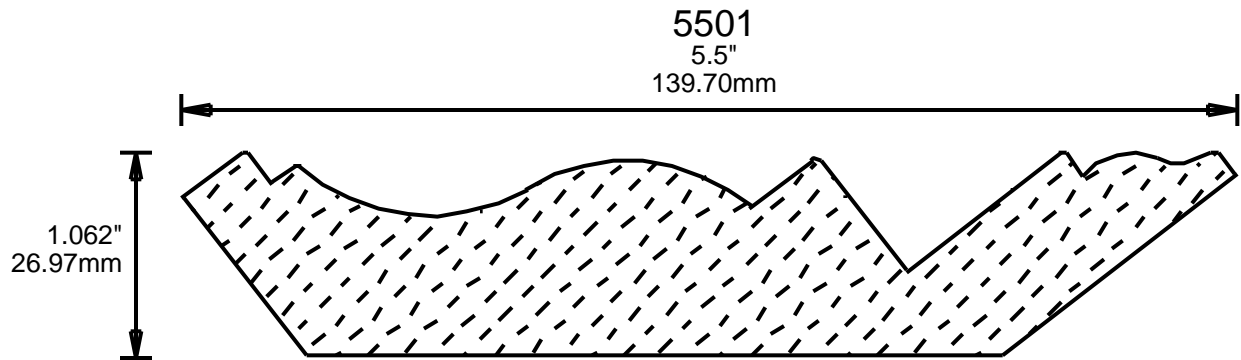
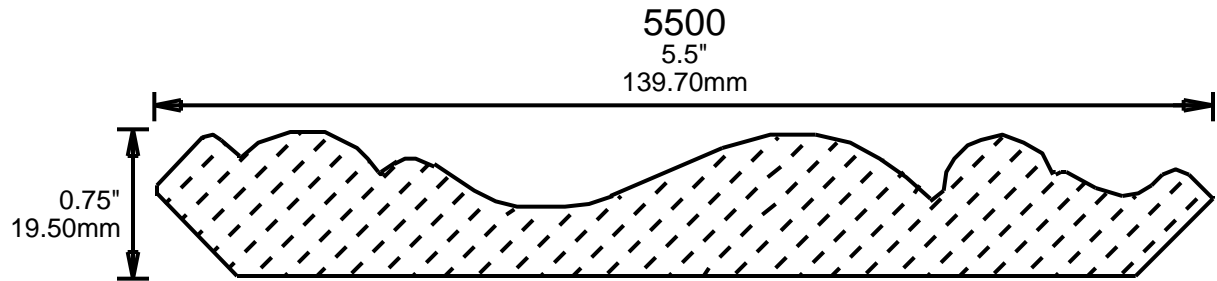
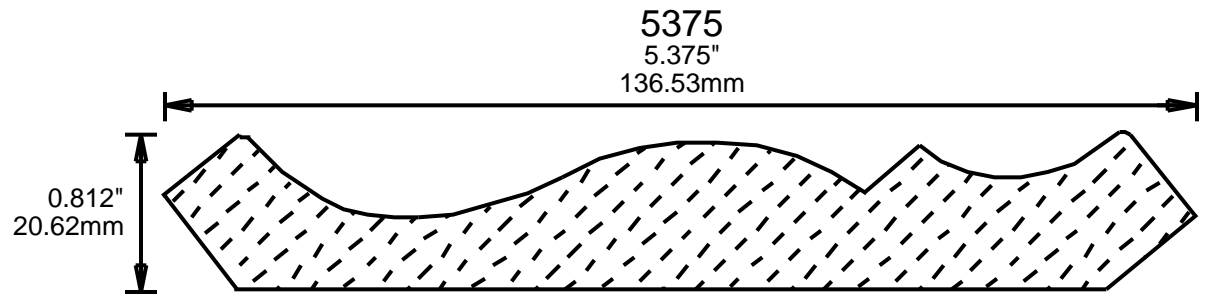
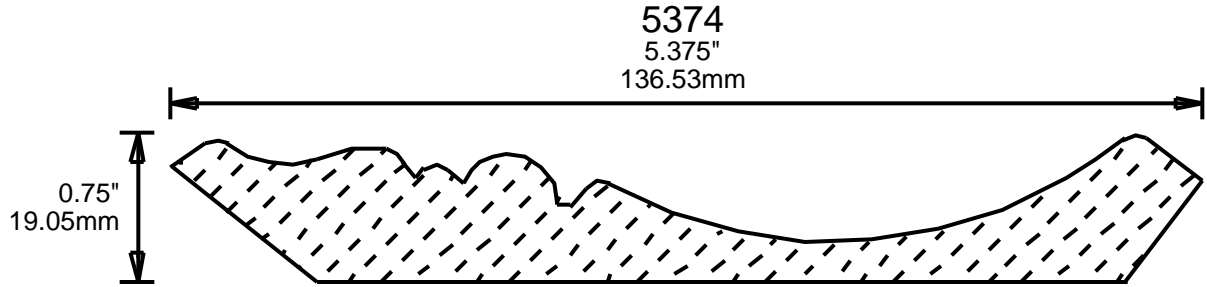

**PRINT  
THIS SECTION**

**RETURN TO  
Table of Contents**

# WEINIG CROWN MOULDING PATTERNS

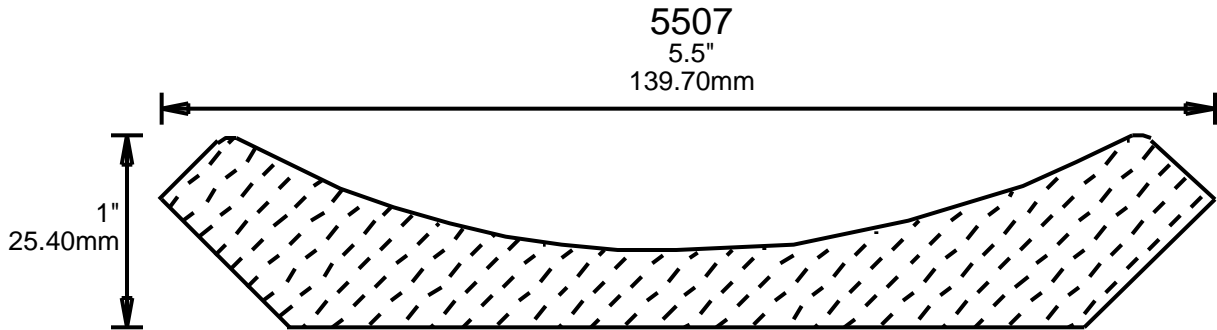
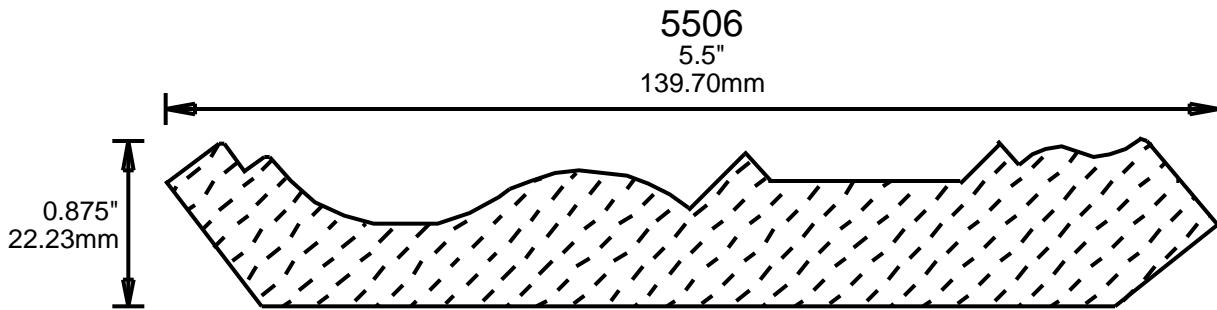
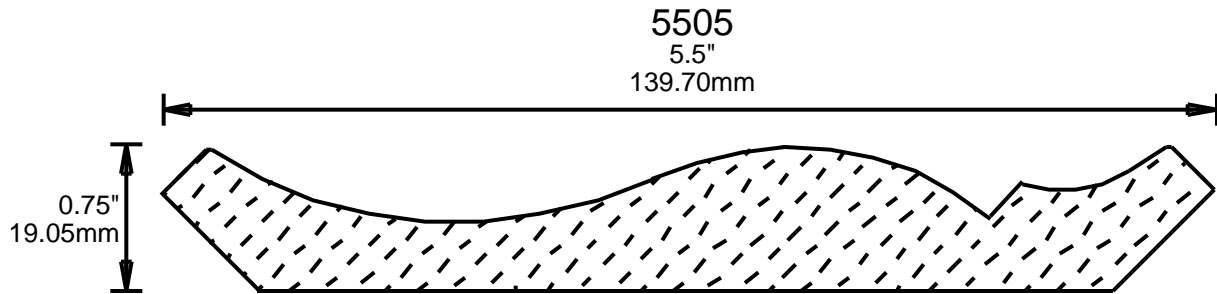
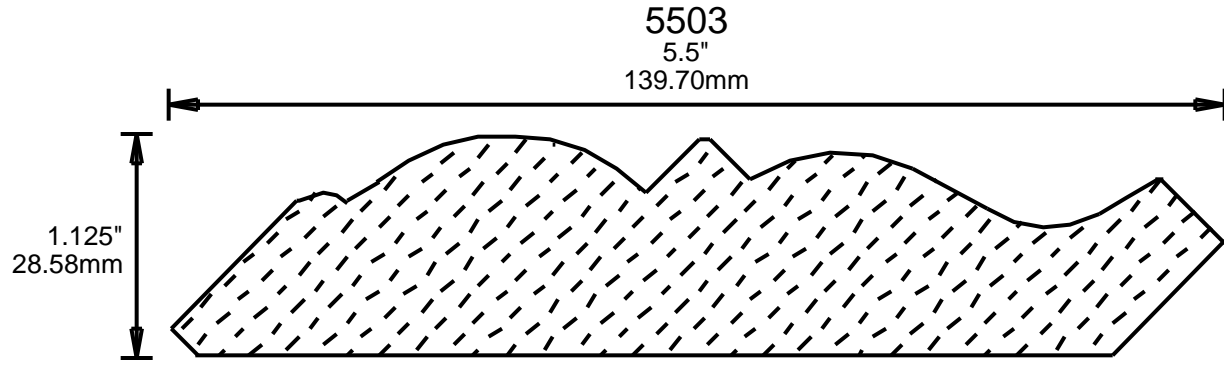

# WEINIG CROWN MOULDING PATTERNS

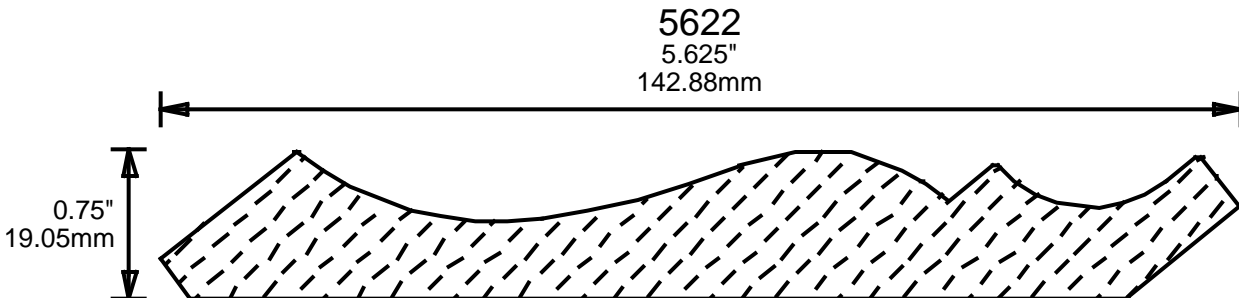
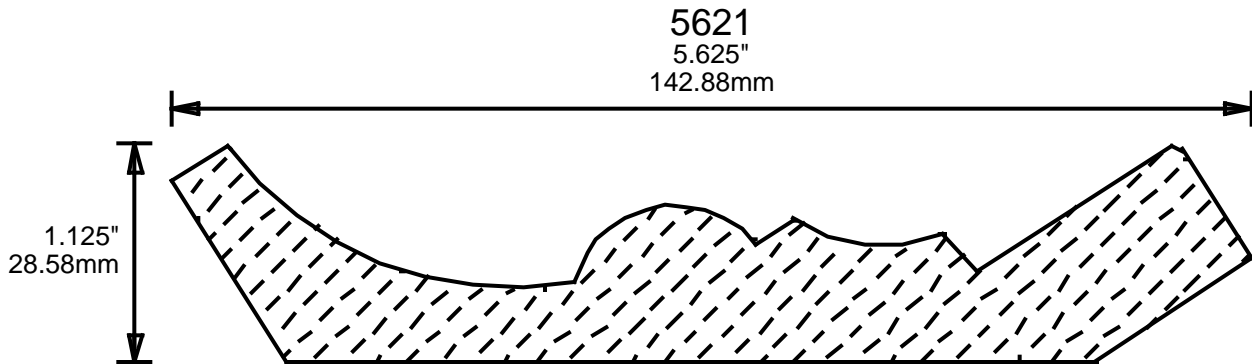
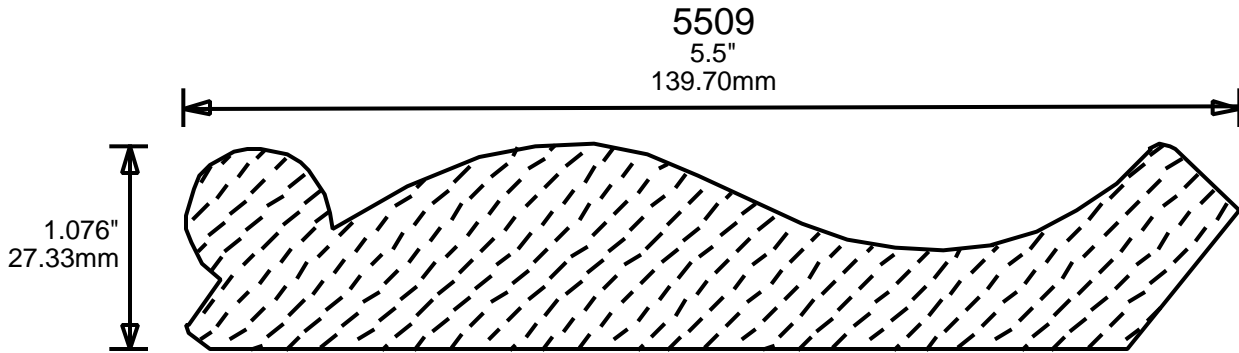
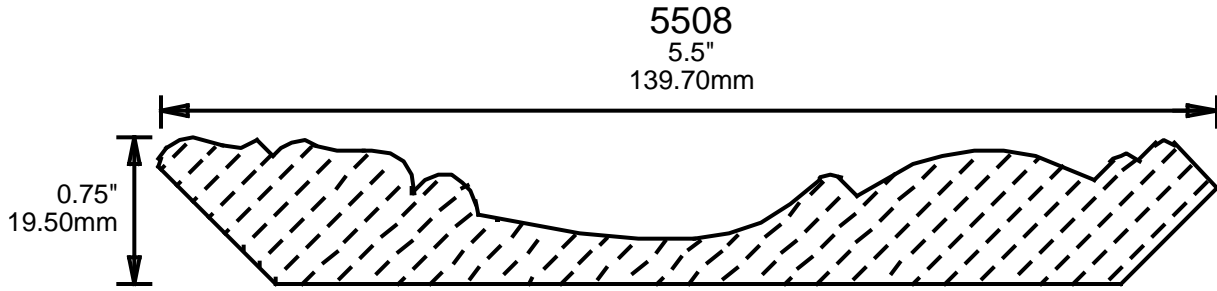

# WEINIG CROWN MOULDING PATTERNS

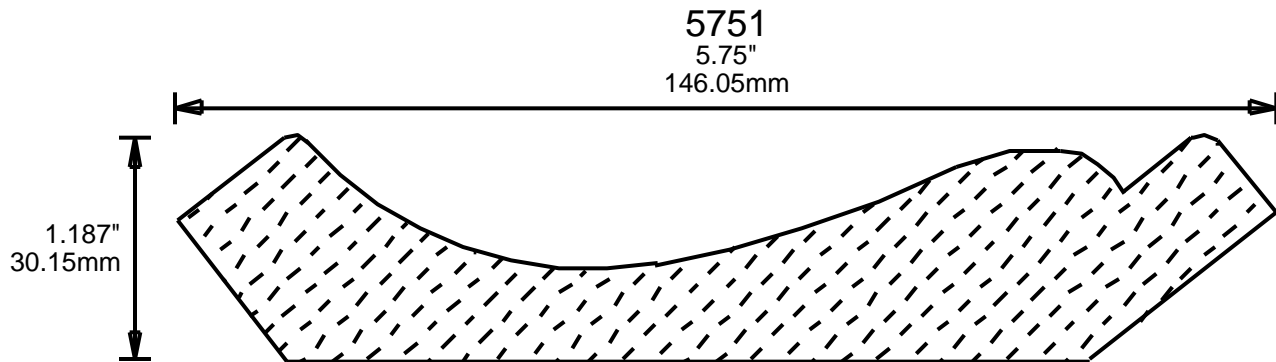
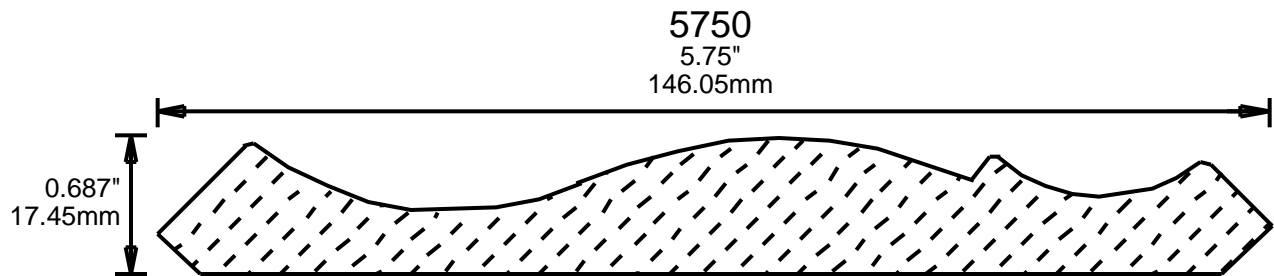
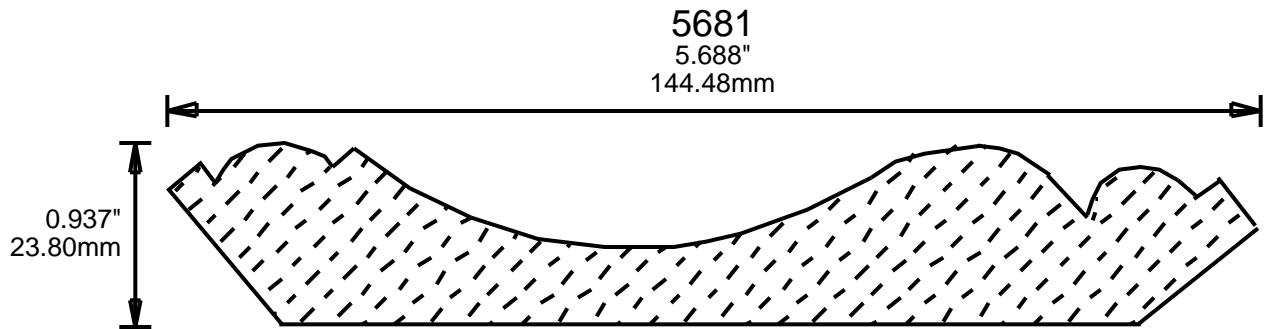
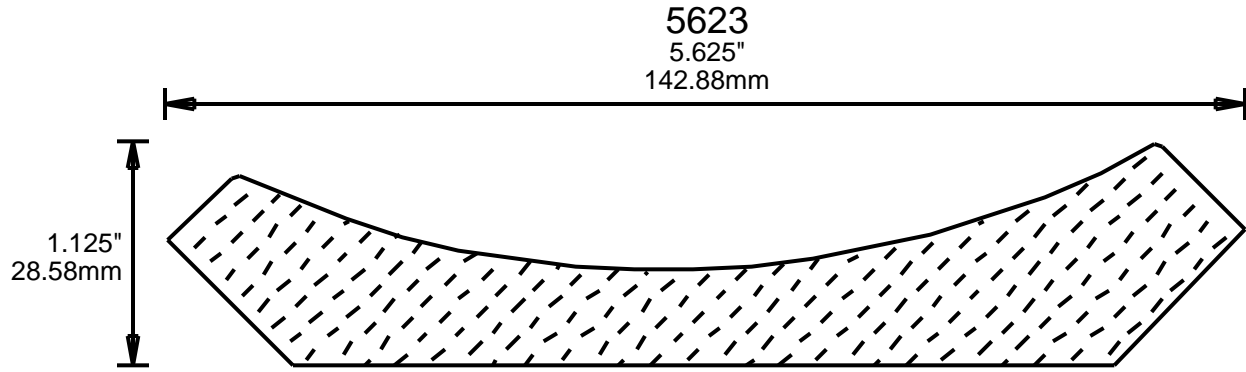

# WEINIG CROWN MOULDING PATTERNS

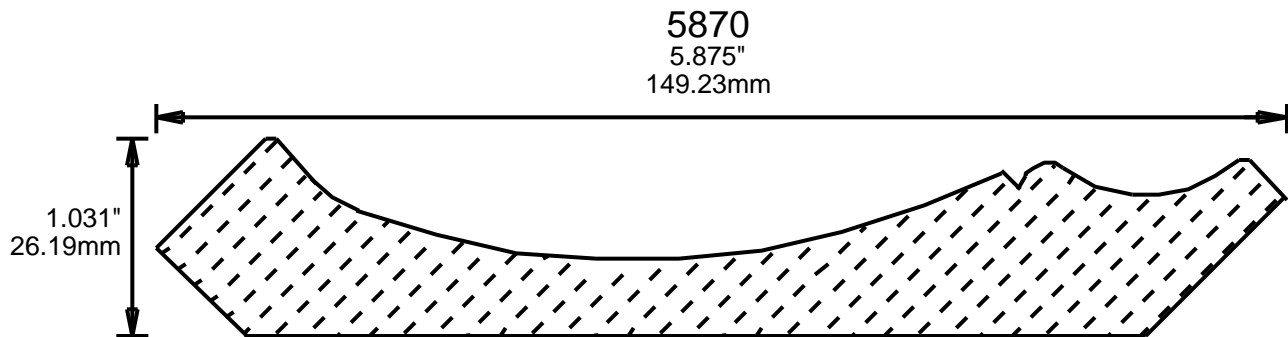
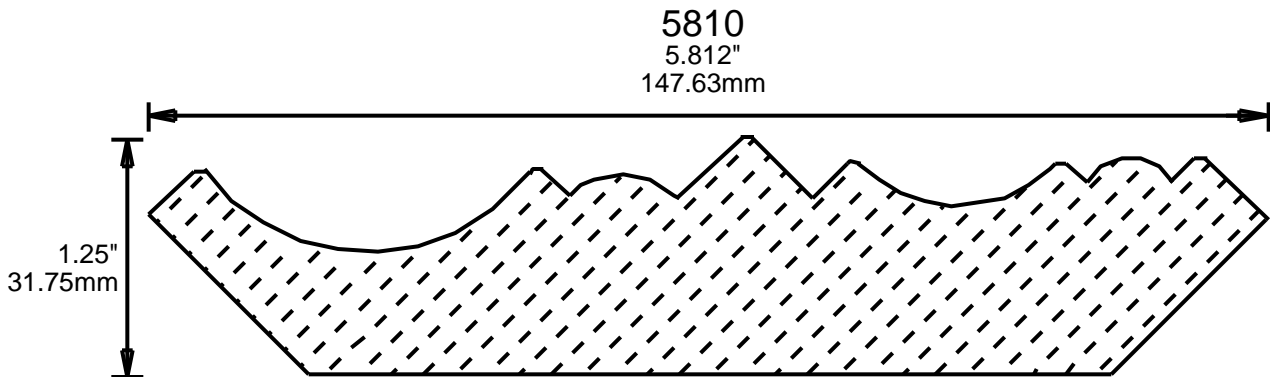
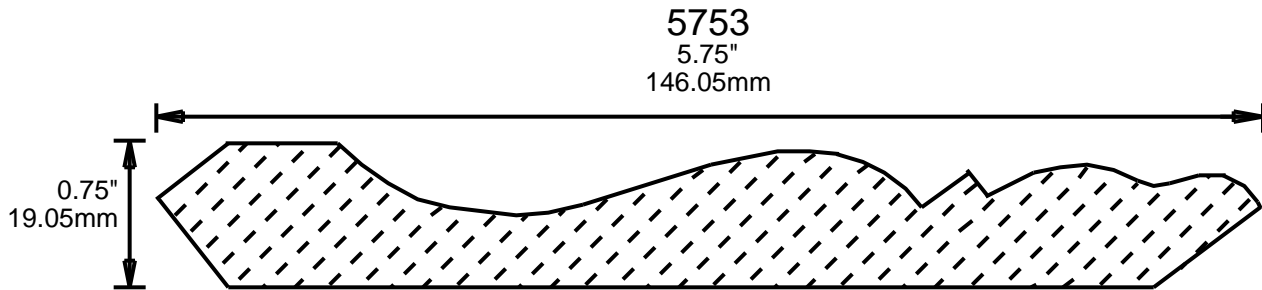
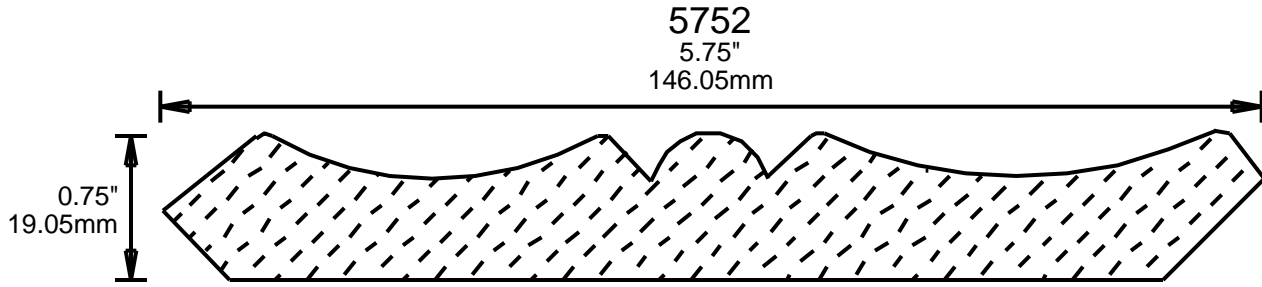

# WEINIG CROWN MOULDING PATTERNS

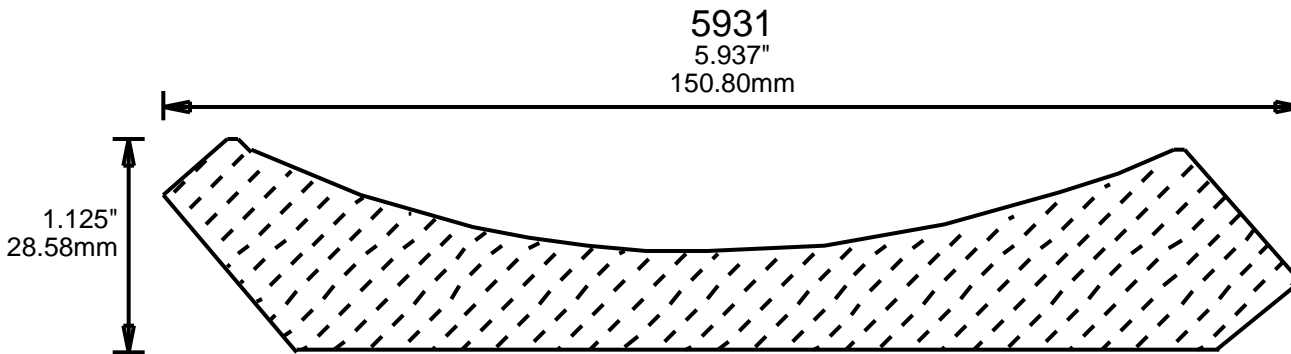
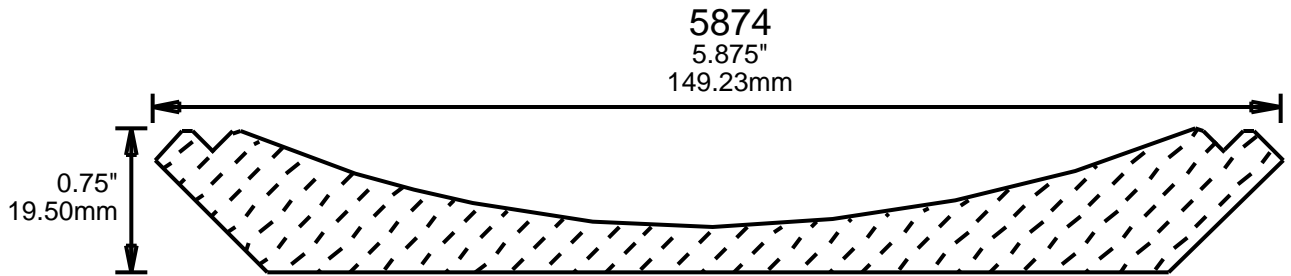
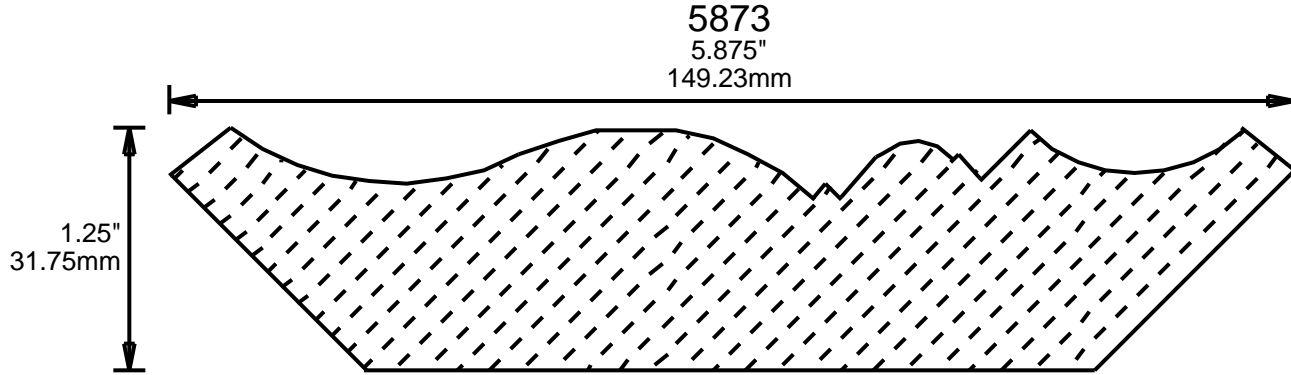
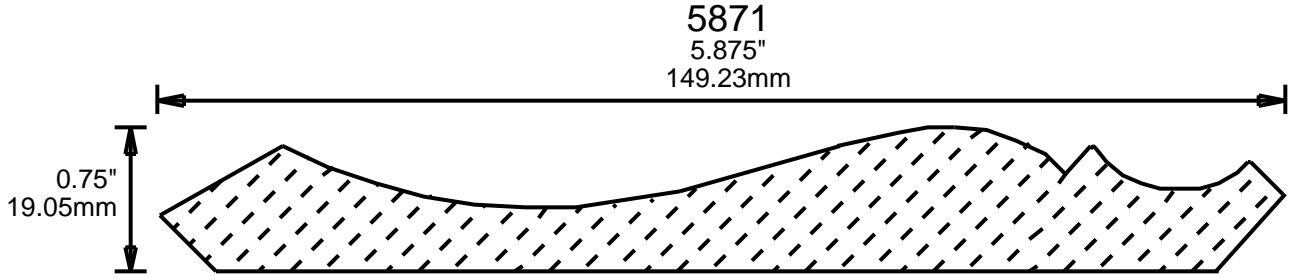



# WEINIG CROWN MOULDING PATTERNS

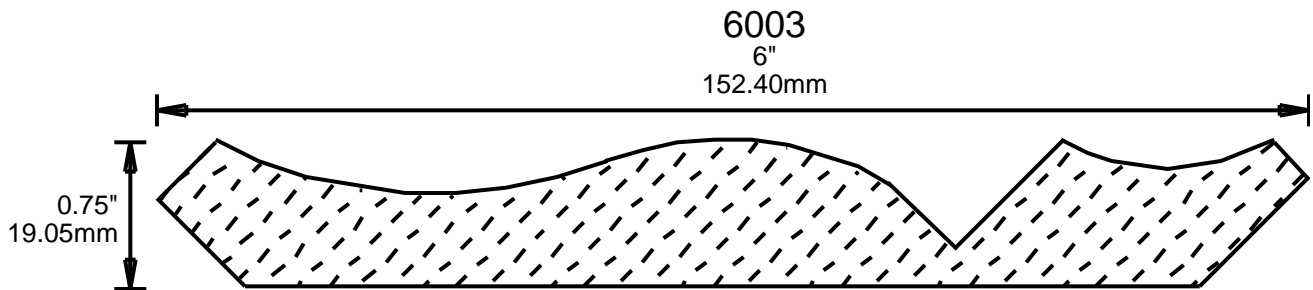
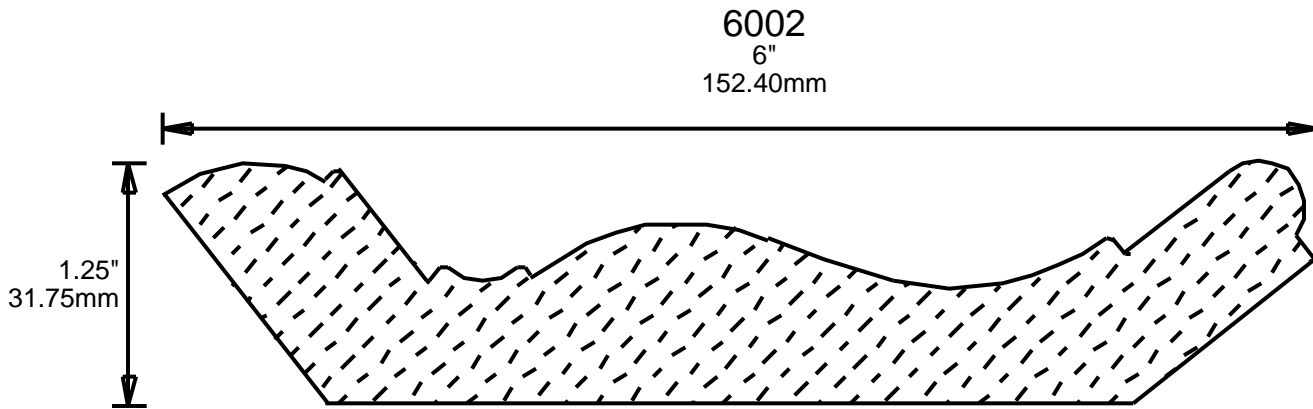
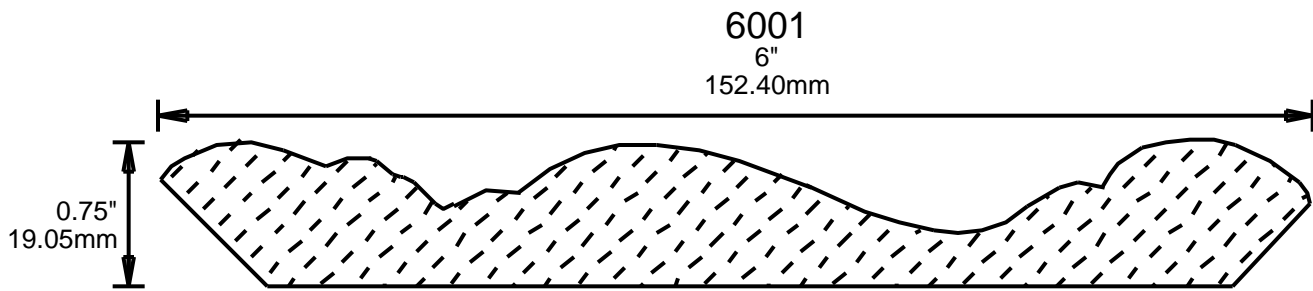
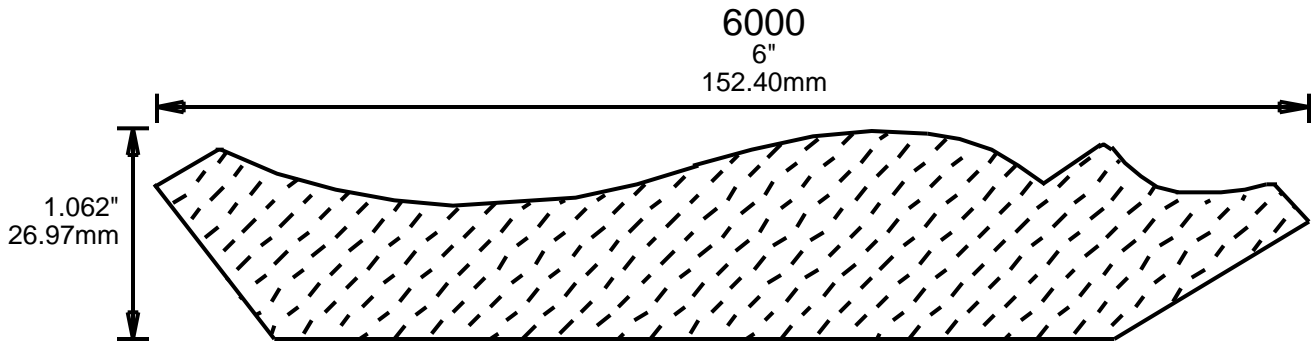

# WEINIG CROWN MOULDING PATTERNS

6004

6"

152.40mm

1.25"  
31.75mm

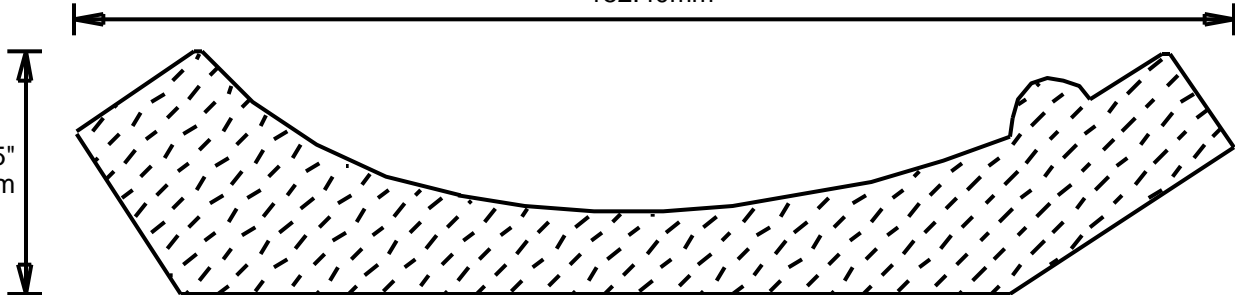

6005

6"

152.40mm

0.812"  
20.62mm

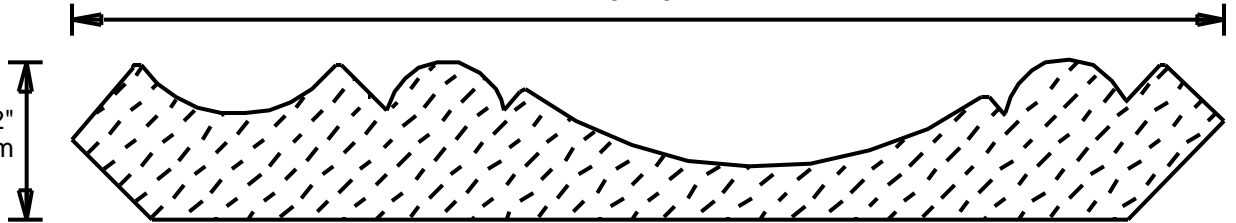

6006

6"

152.40mm

0.75"  
19.05mm

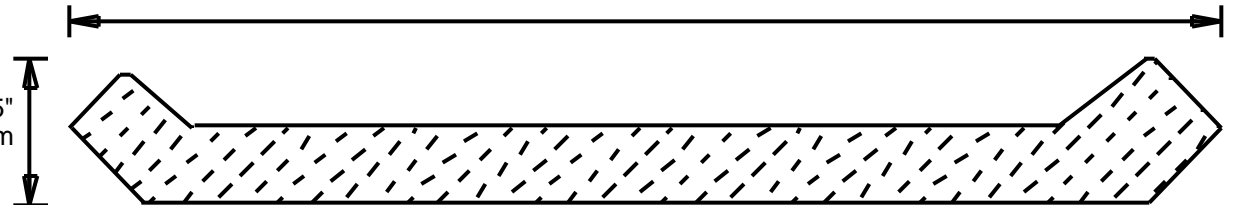

6007

6"

152.40mm

1.125"  
28.58mm

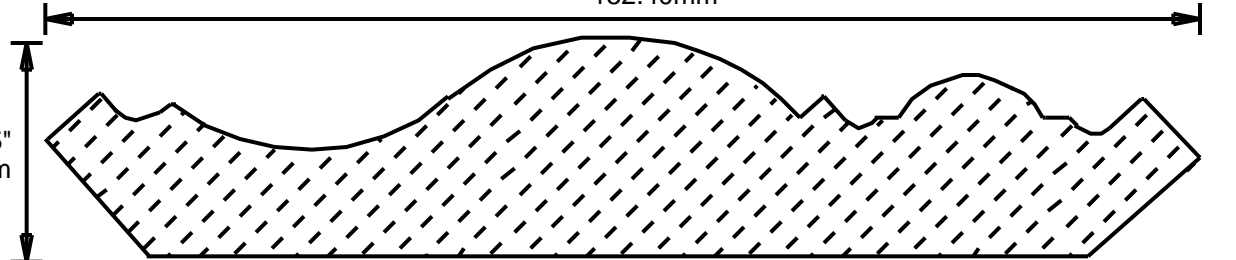

6008

6"

152.40mm

1"  
25.40mm

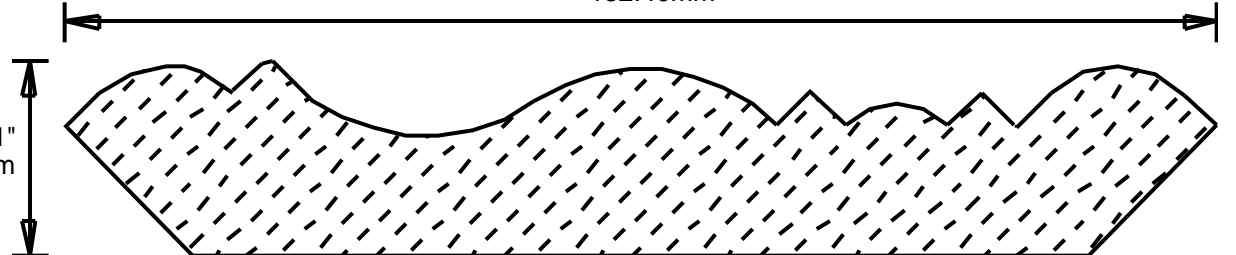

# WEINIG CROWN MOULDING PATTERNS

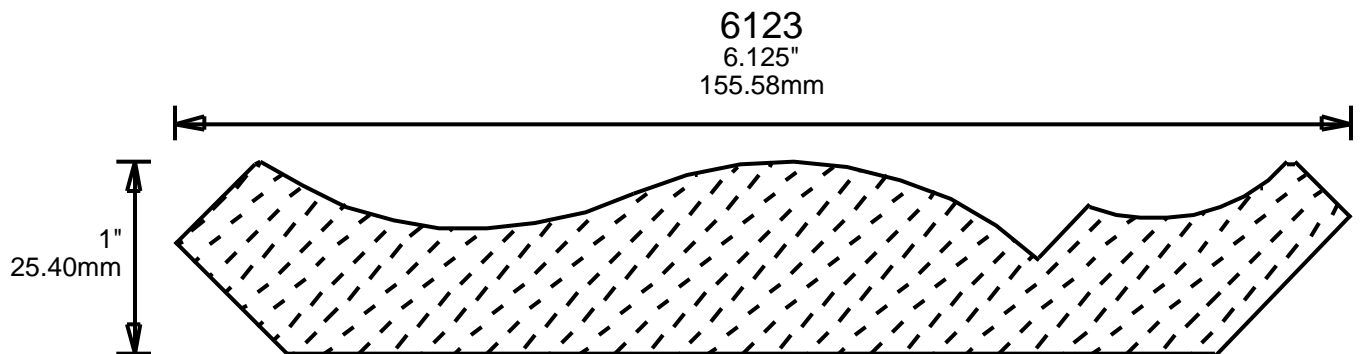
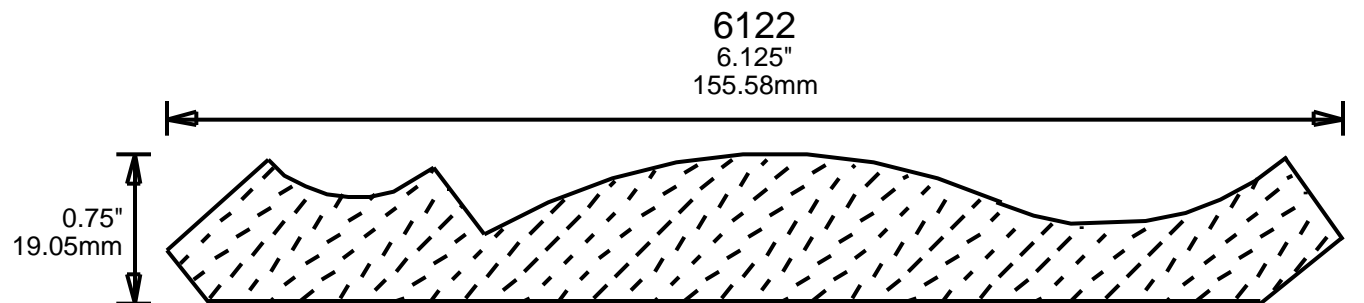
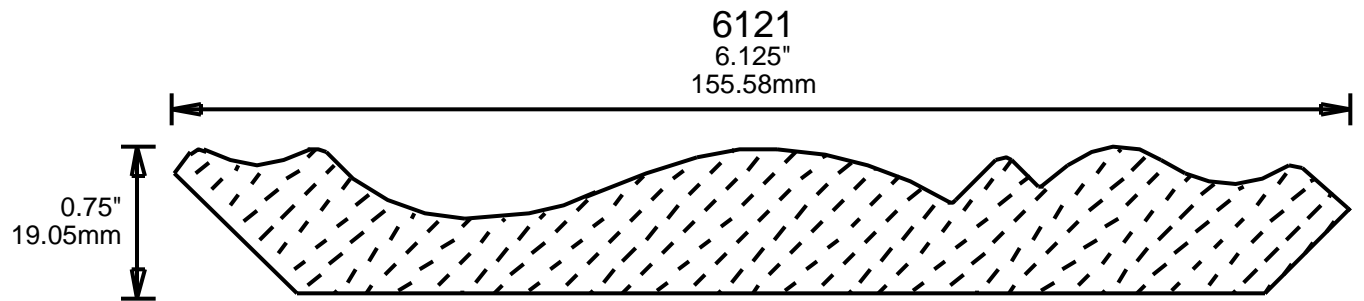
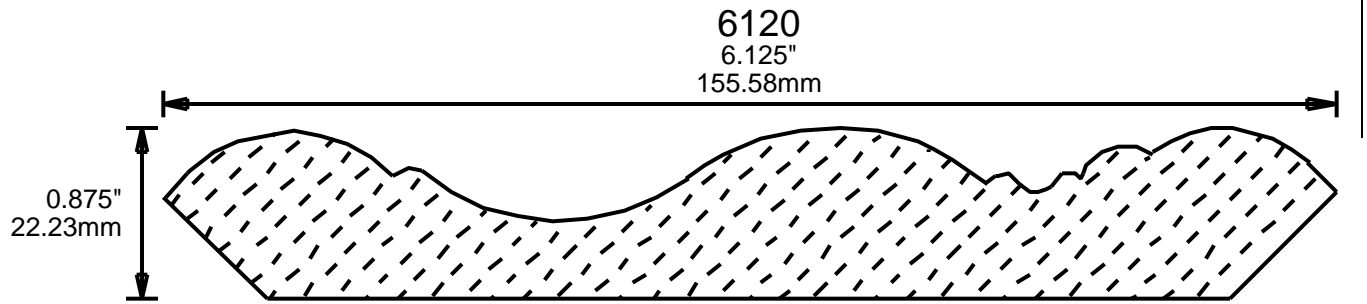
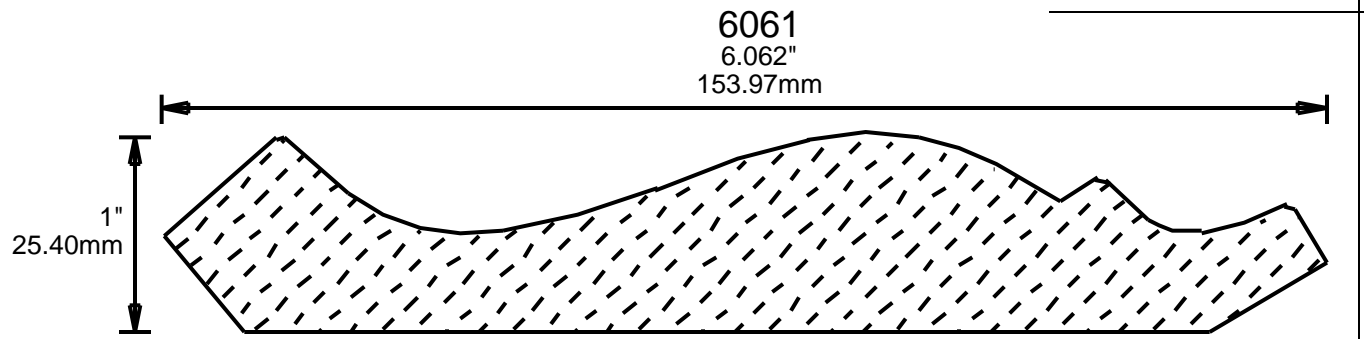

# WEINIG CROWN MOULDING PATTERNS

6124  
6.125"  
155.58mm

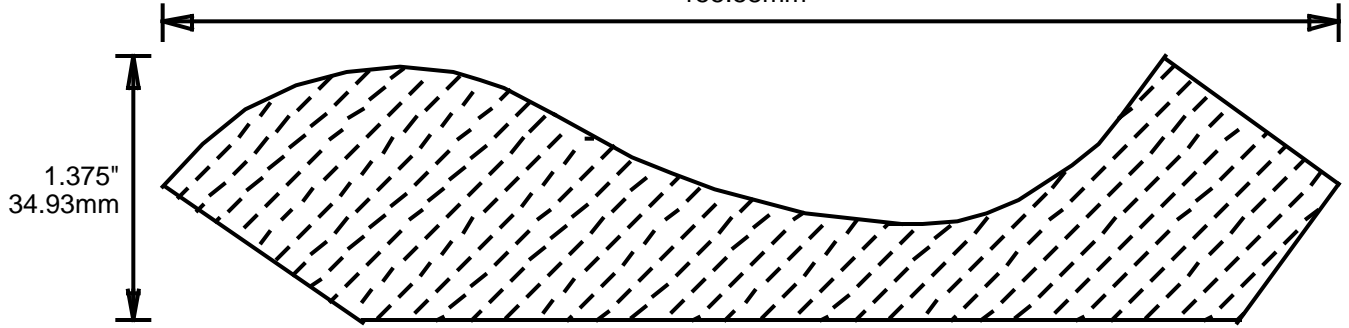

6125  
6.125"  
155.58mm

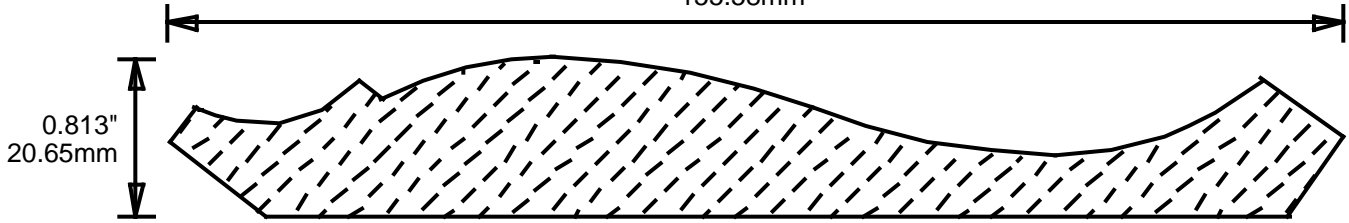

6250  
6.25"  
158.75mm

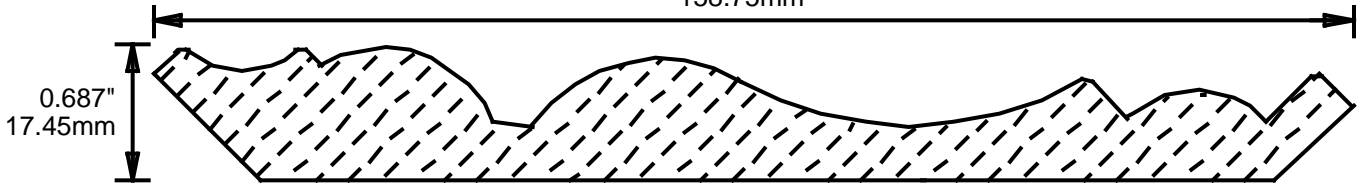

6251  
6.25"  
158.75mm

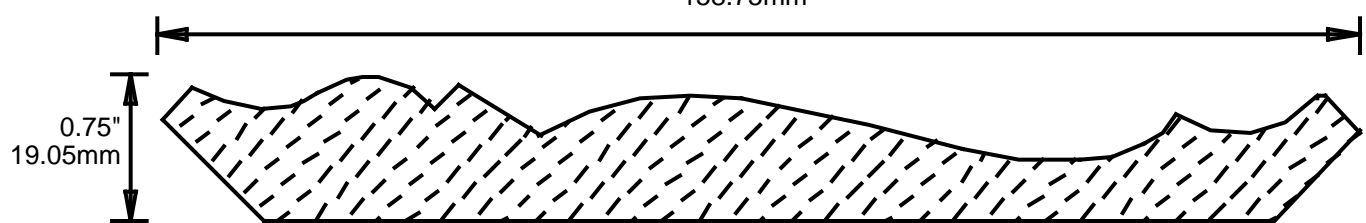

# WEINIG CROWN MOULDING PATTERNS

6252  
6.25"  
158.75mm

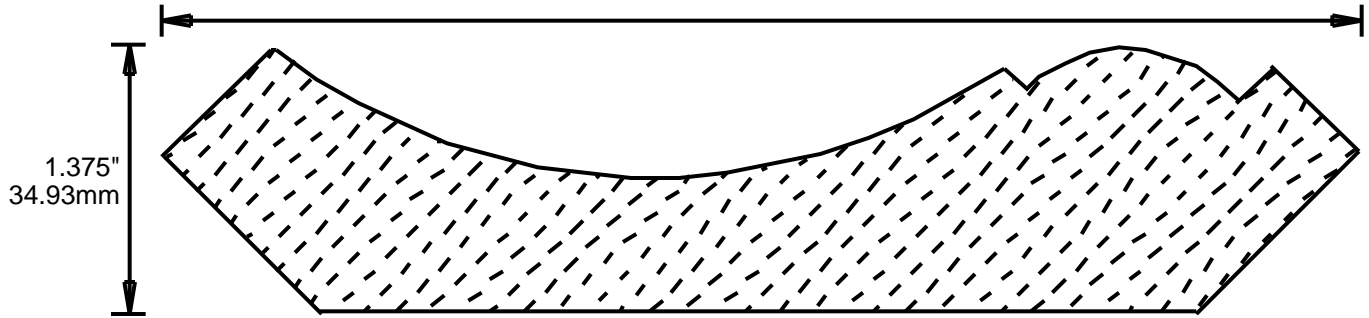

6253  
6.25"  
158.75mm

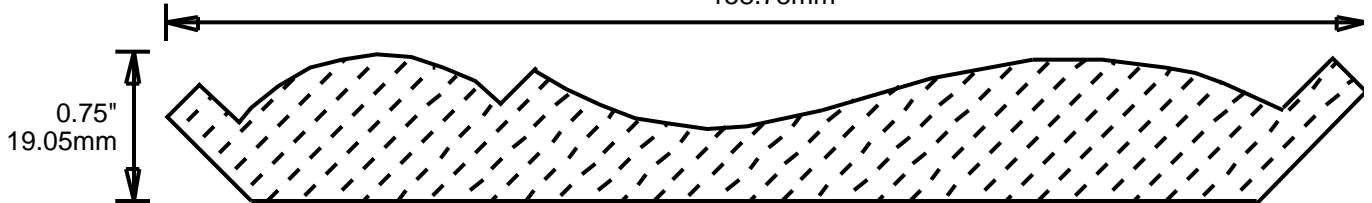

6254  
6.25"  
158.75mm

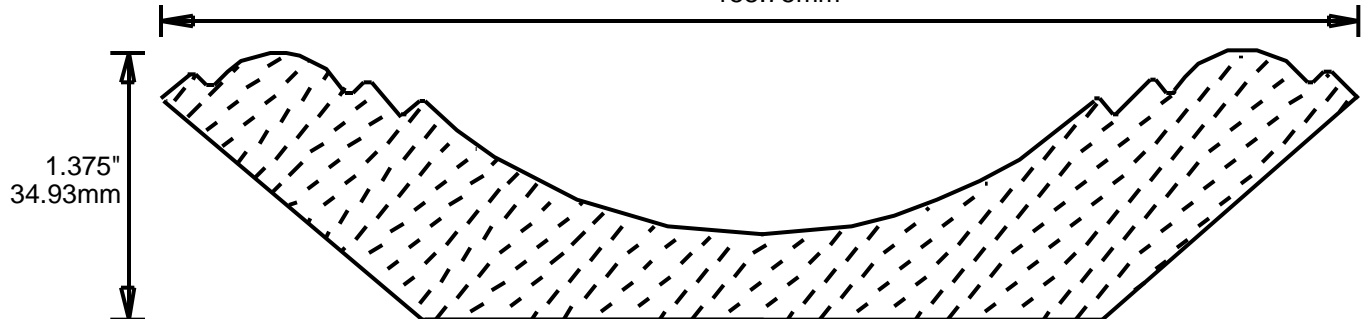

6255  
6.25"  
158.75mm

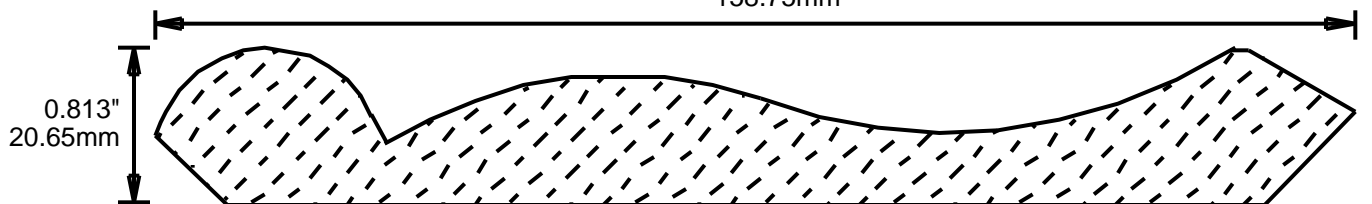

# WEINIG CROWN MOULDING PATTERNS

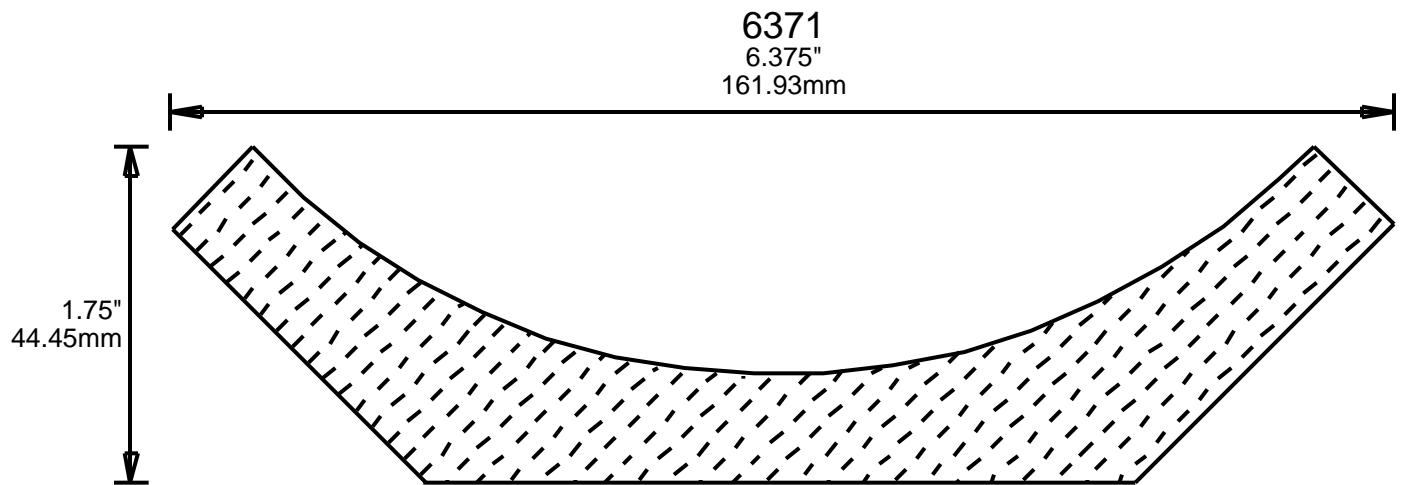
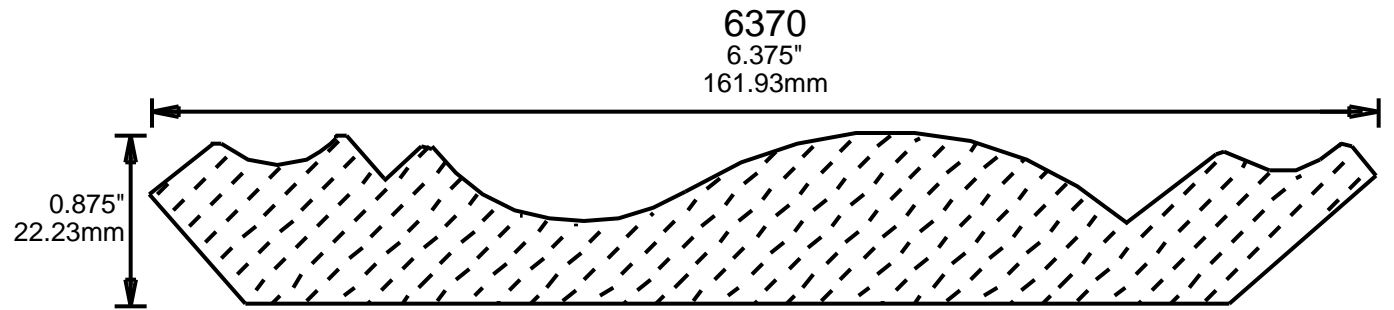
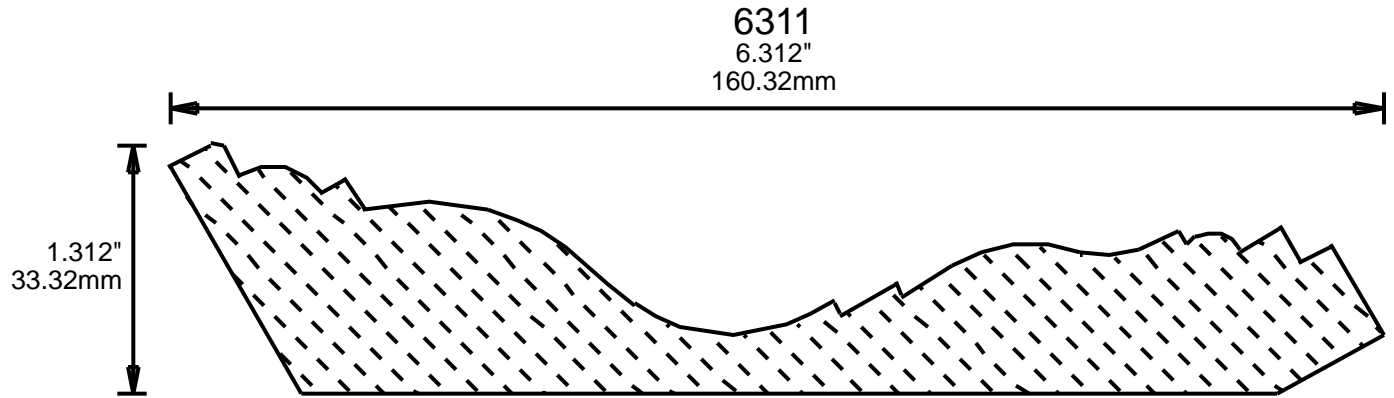
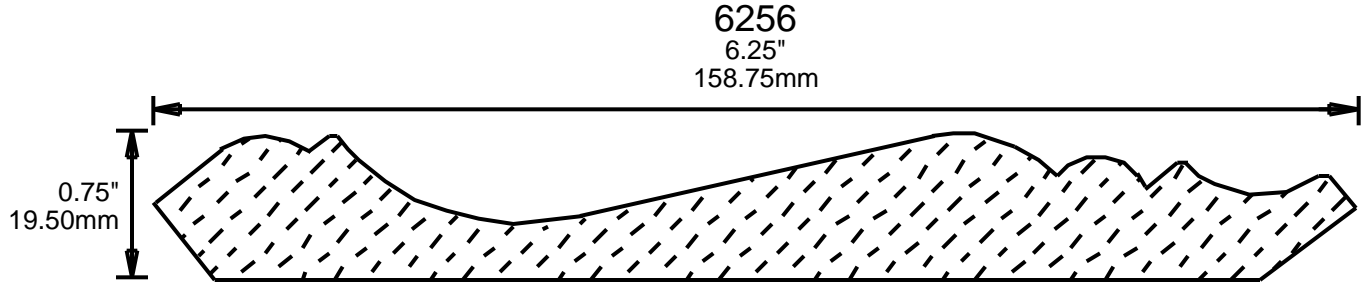

# WEINIG CROWN MOULDING PATTERNS

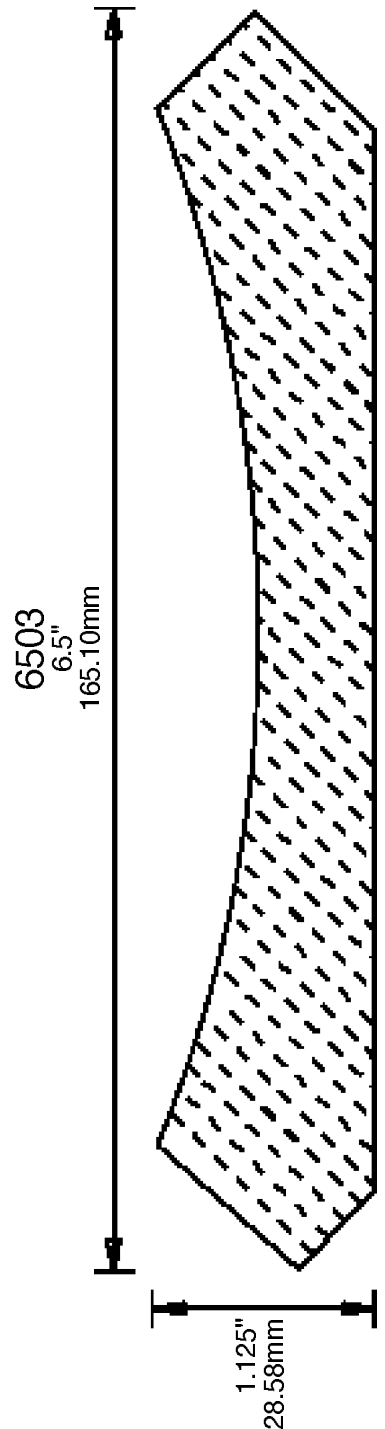
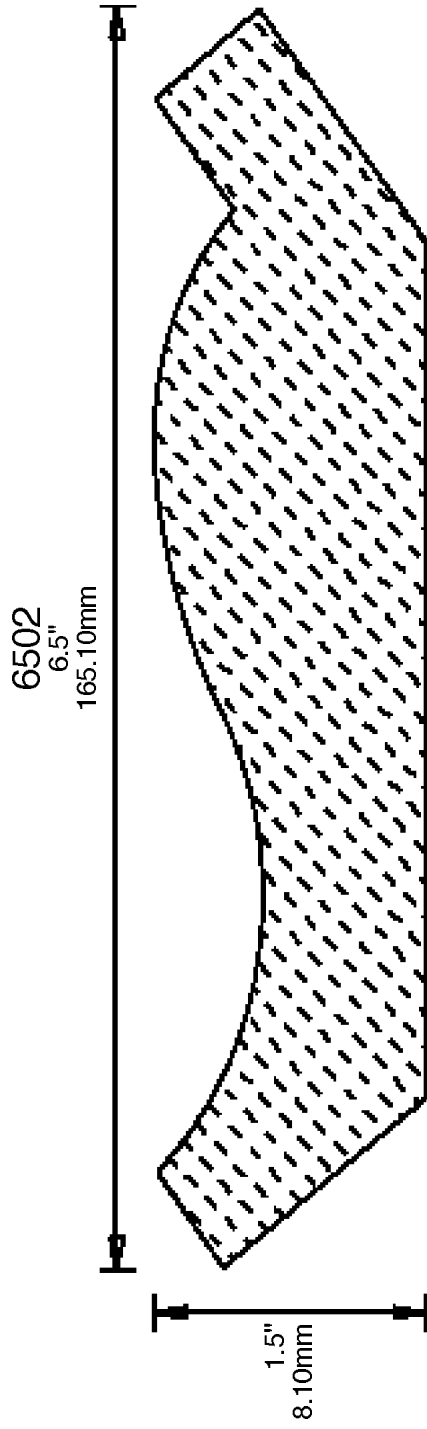
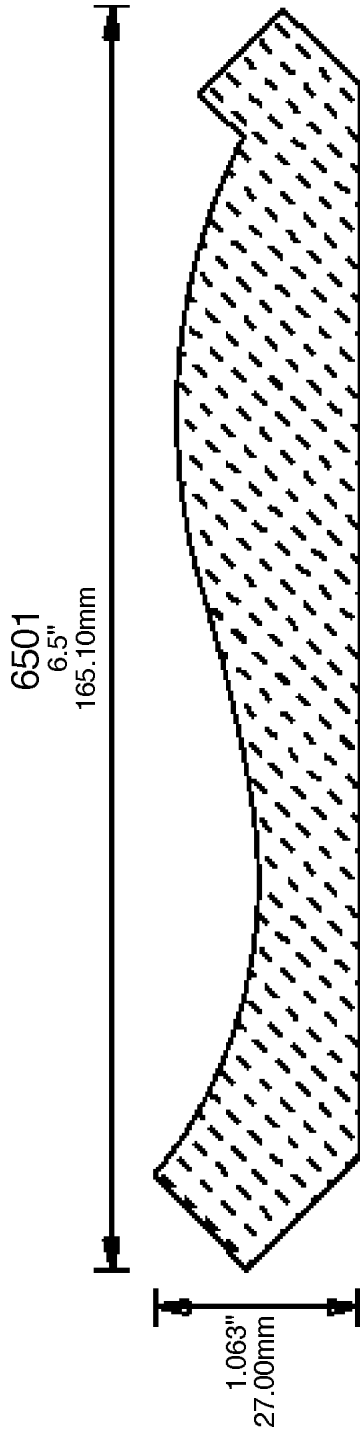
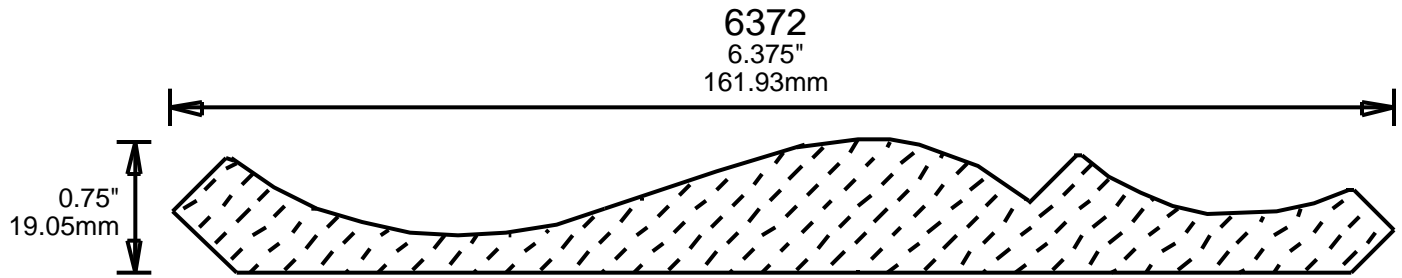

**PRINT  
THIS SECTION**

**RETURN TO  
Table of Contents**

# WEINIG CROWN MOULDING PATTERNS

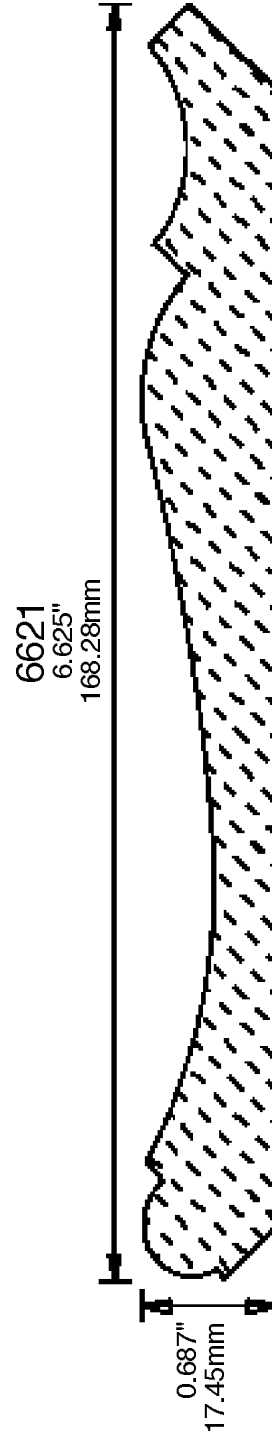
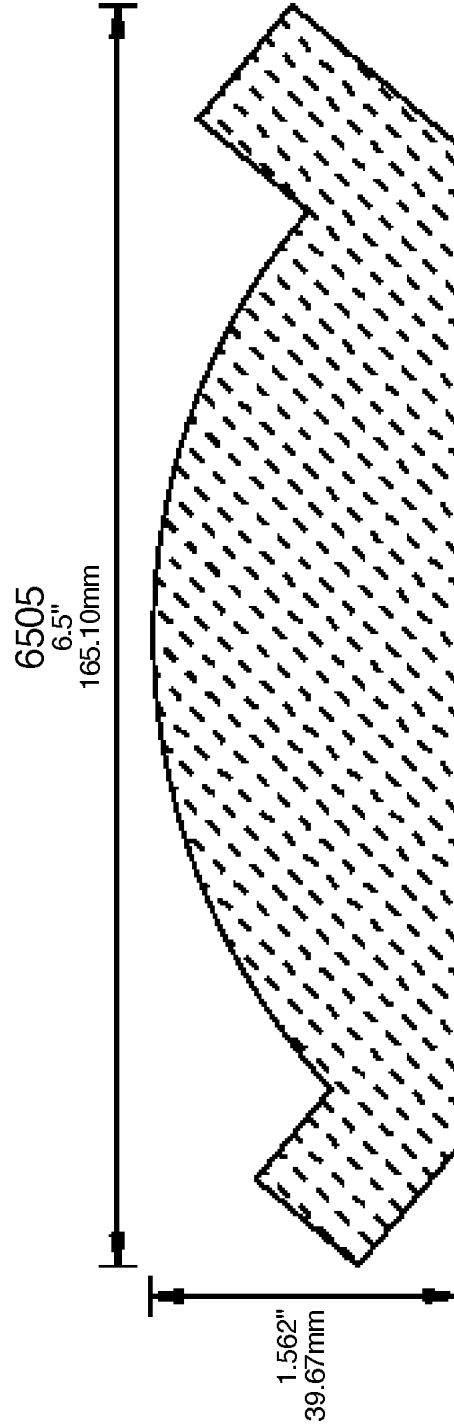
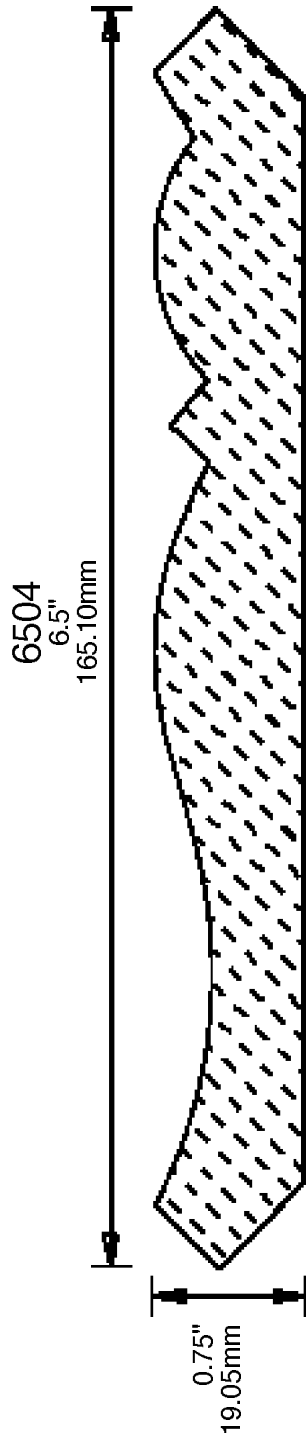



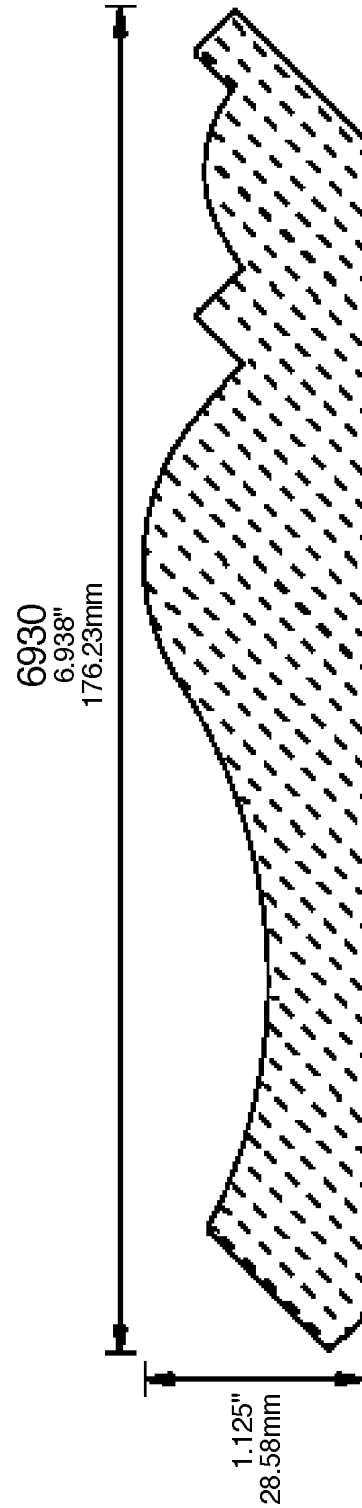
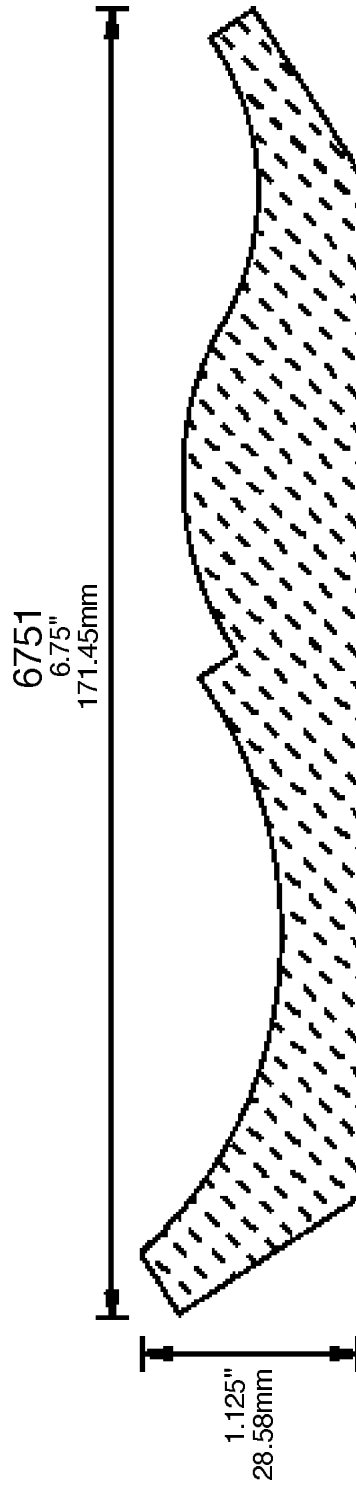
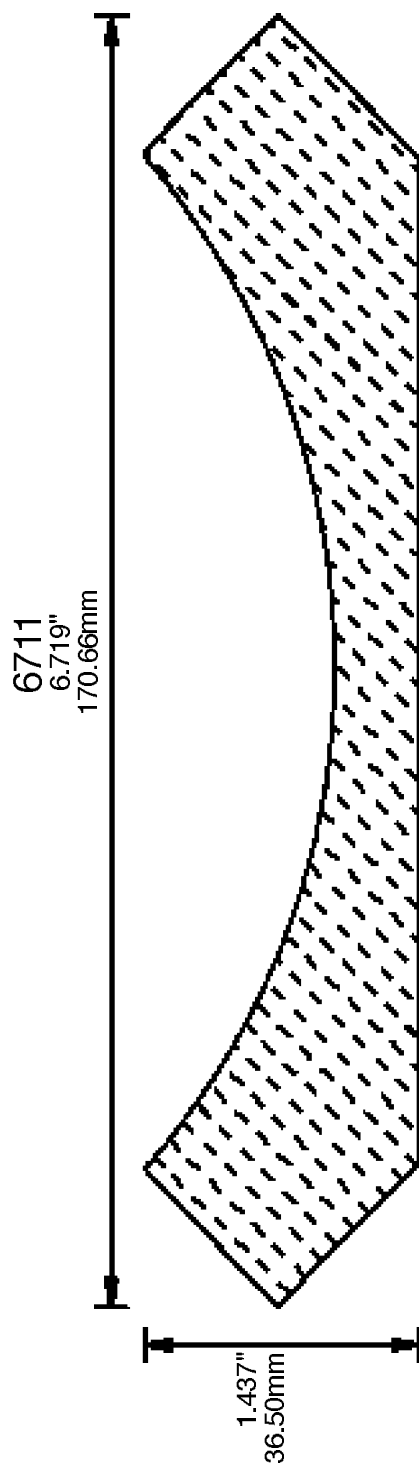

# WEINIG CROWN MOULDING PATTERNS

6931  
6.938"  
176.23mm

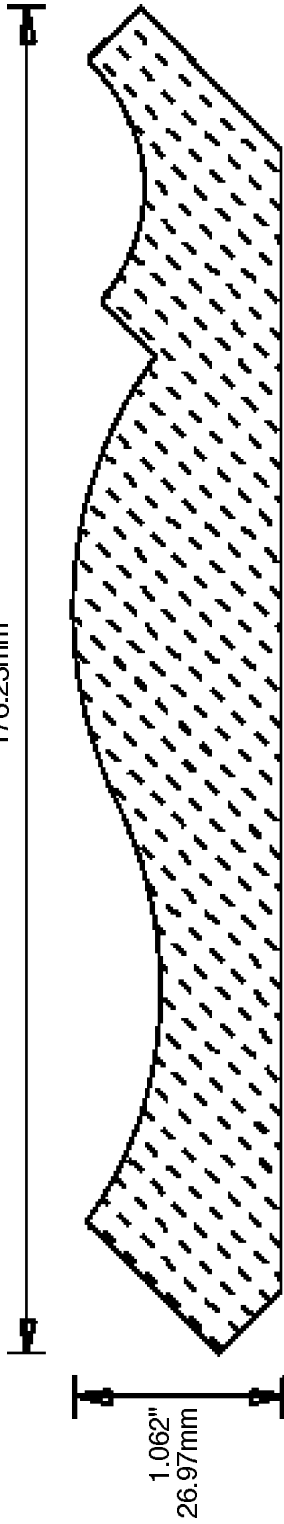

7000  
7"  
177.80mm

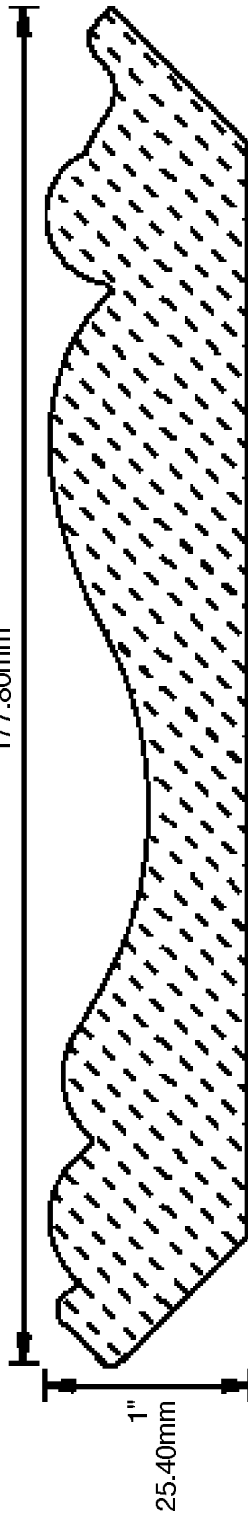

7001  
7"  
177.80mm

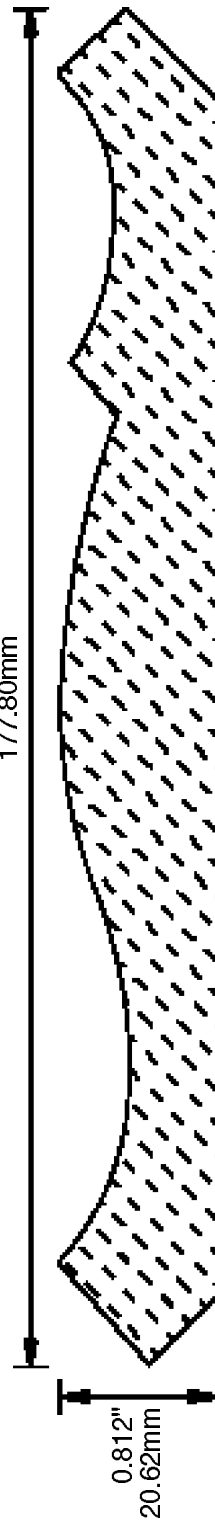

7002  
7"  
177.80mm

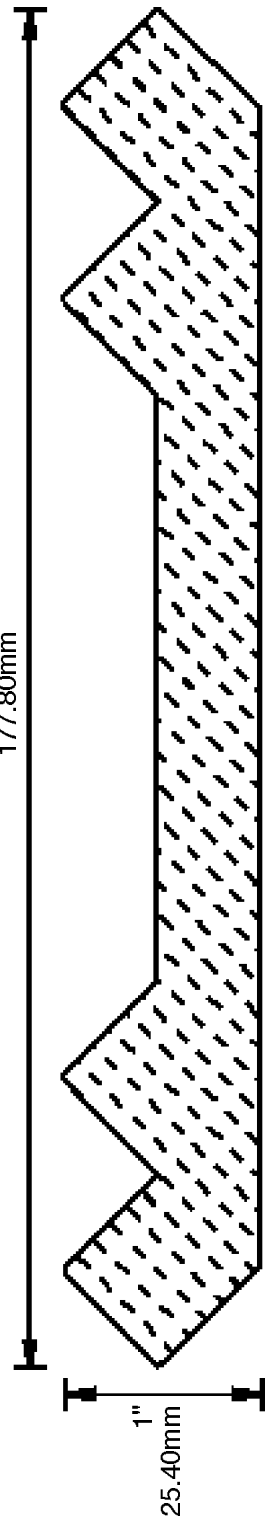

# WEINIG CROWN MOULDING PATTERNS

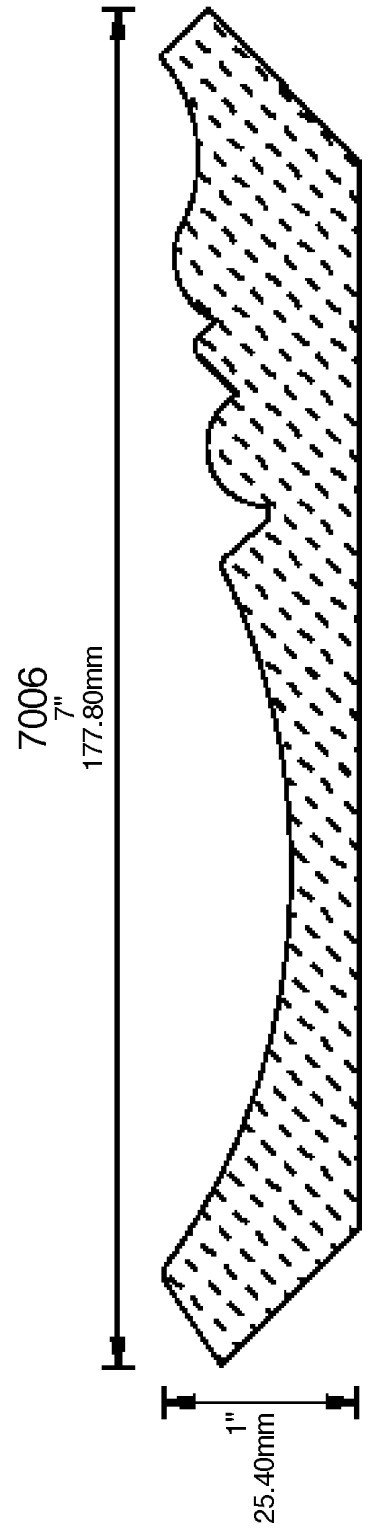
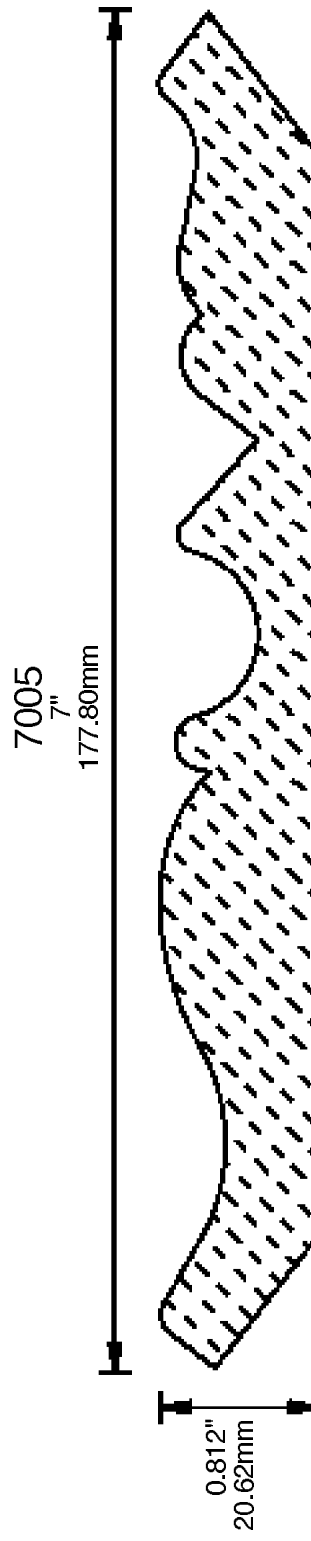
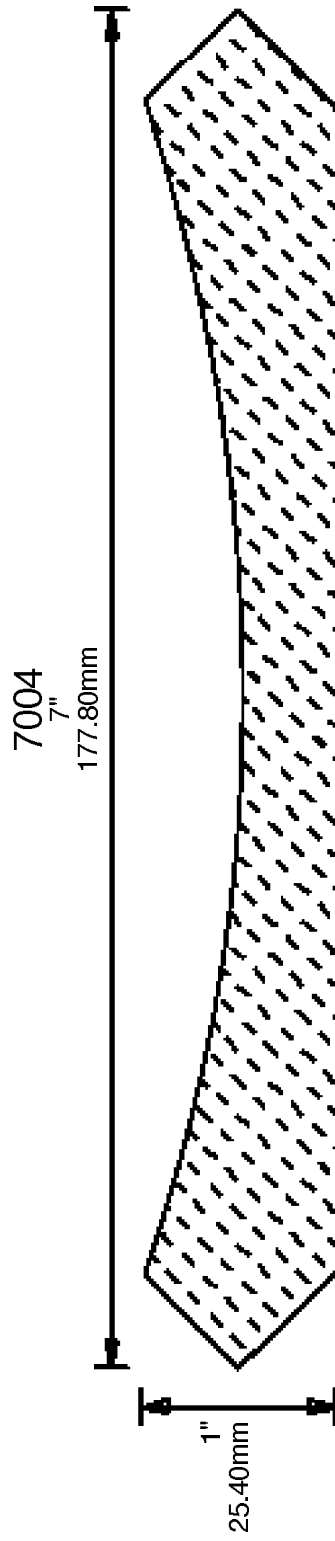
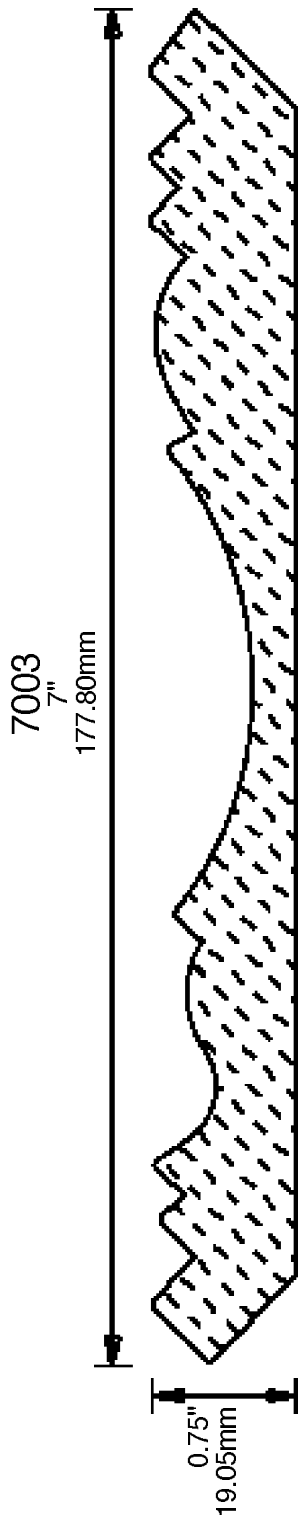

# WEINIG CROWN MOULDING PATTERNS

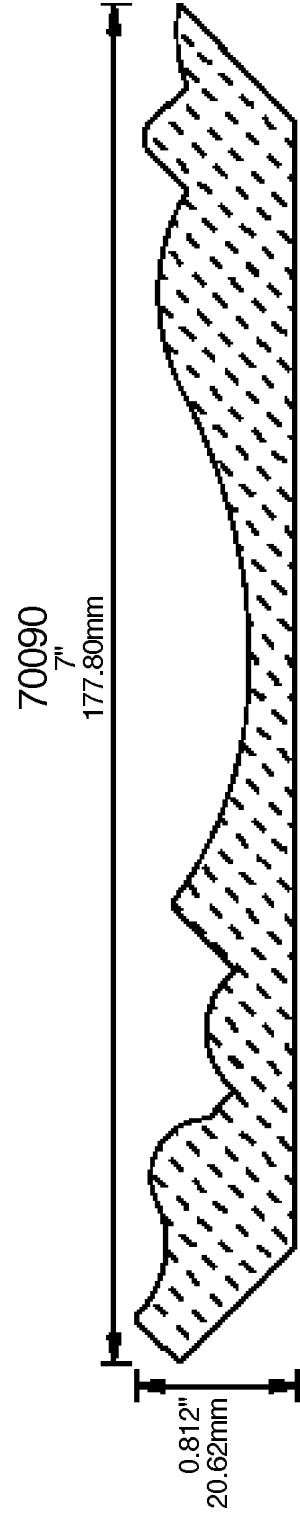
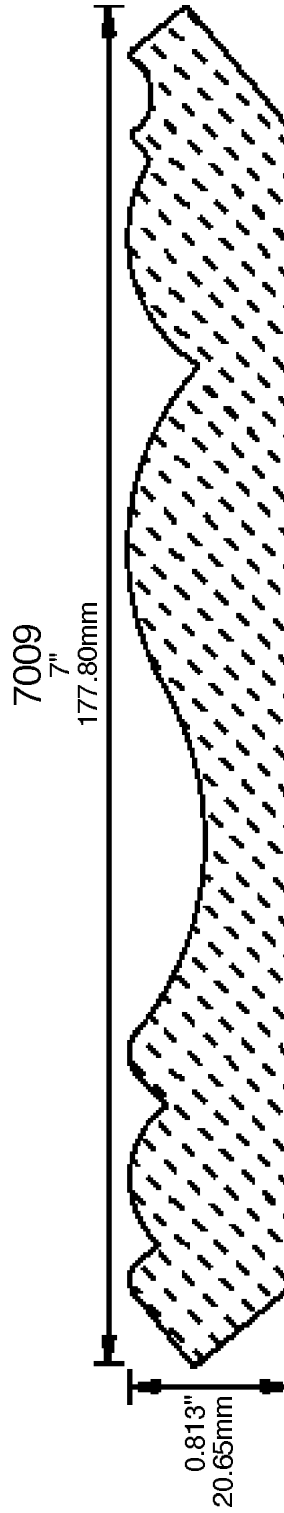
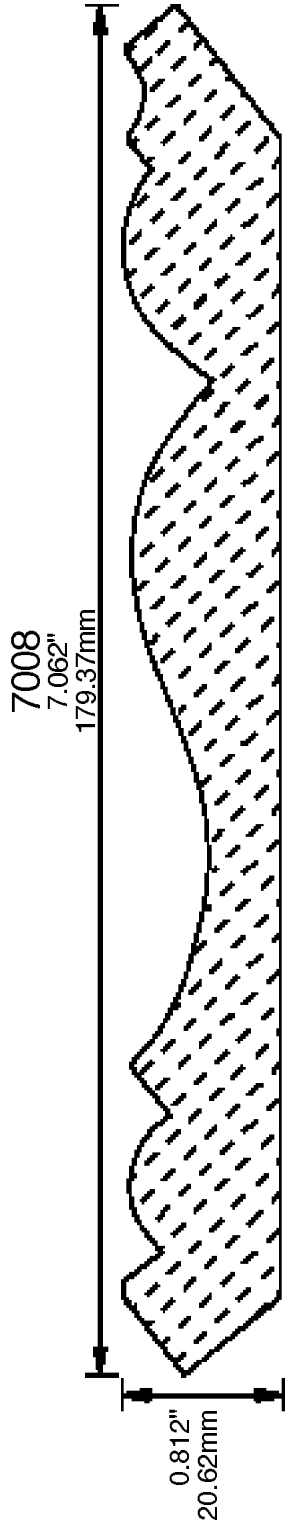
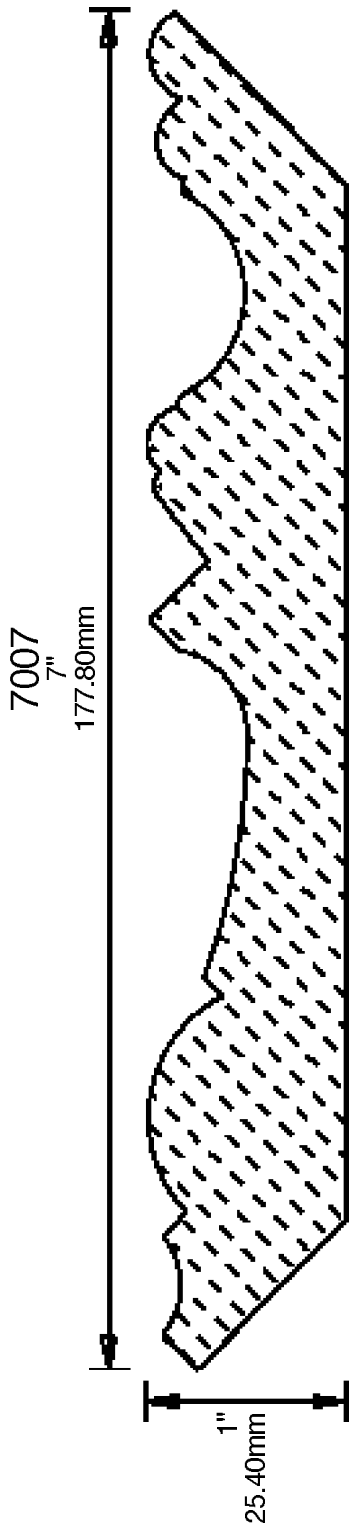

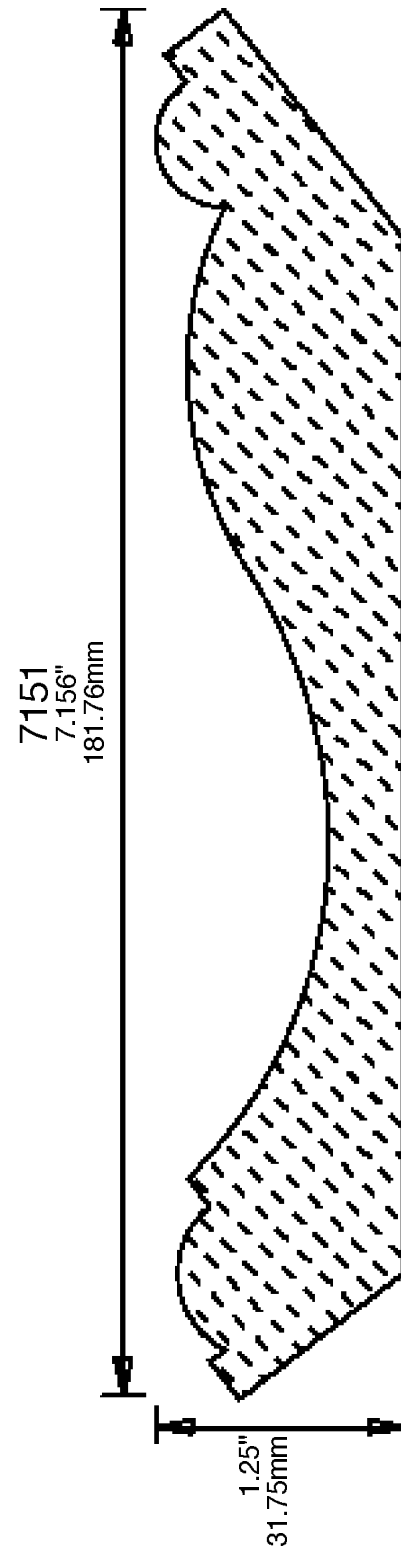
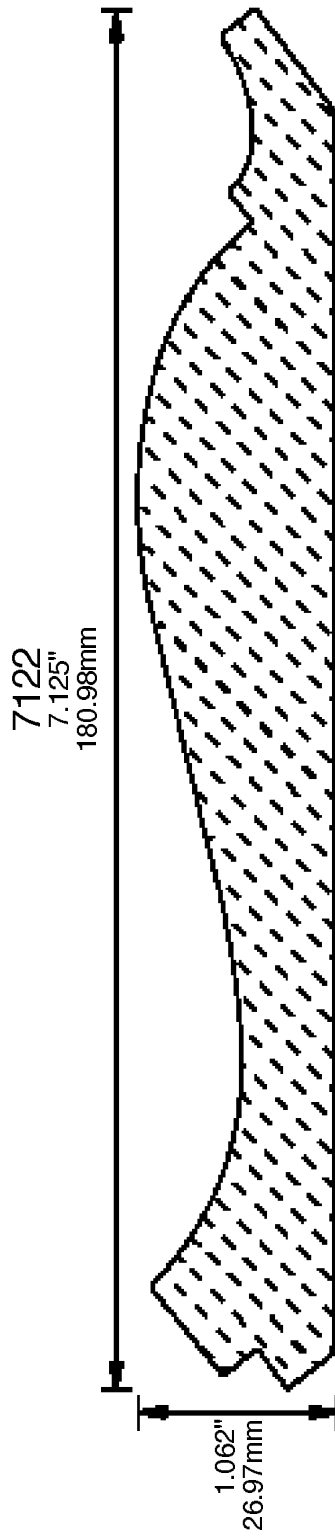
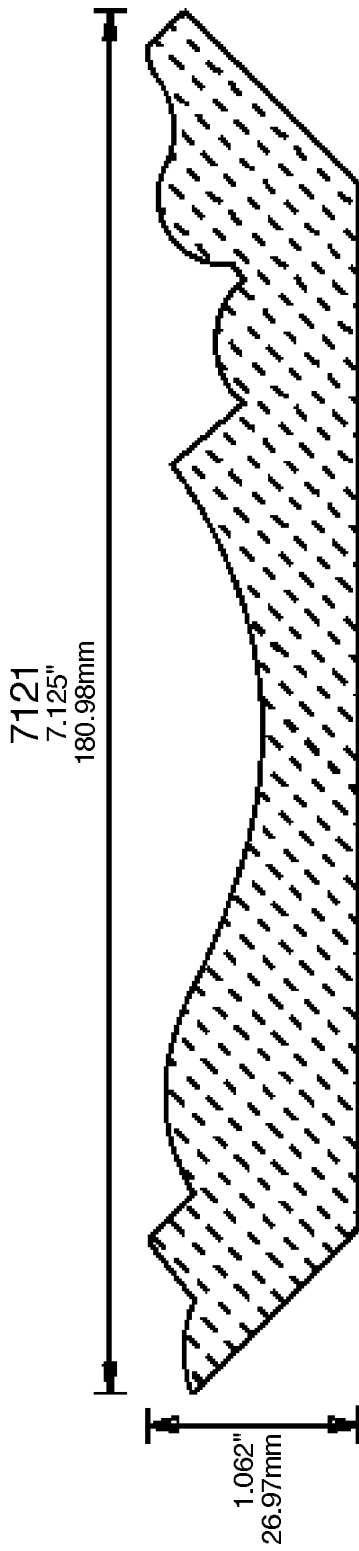

# WEINIG CROWN MOULDING PATTERNS

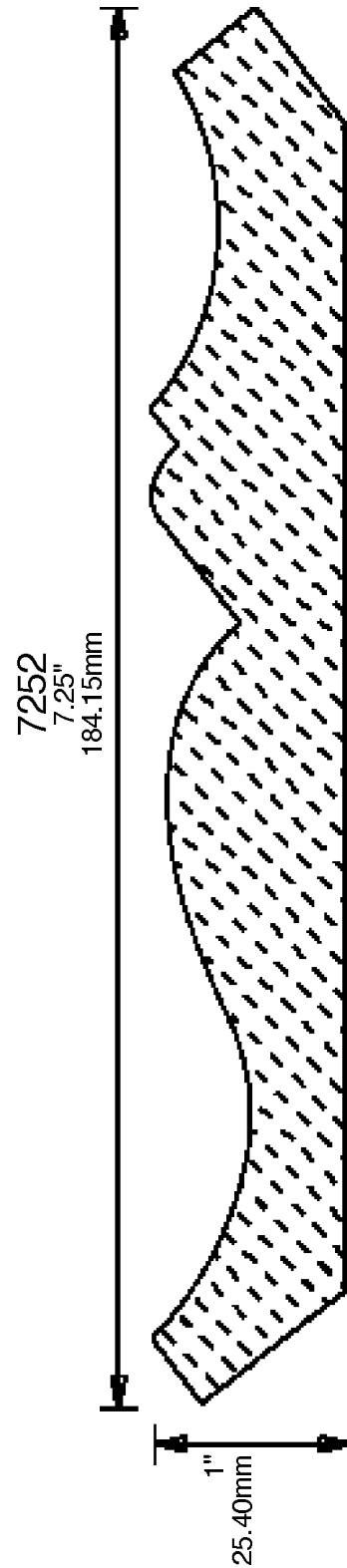
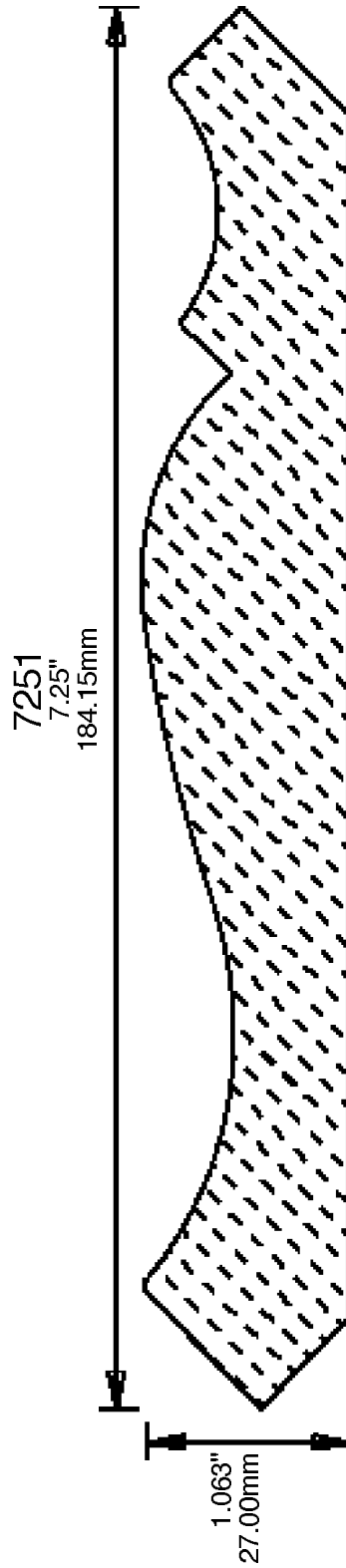
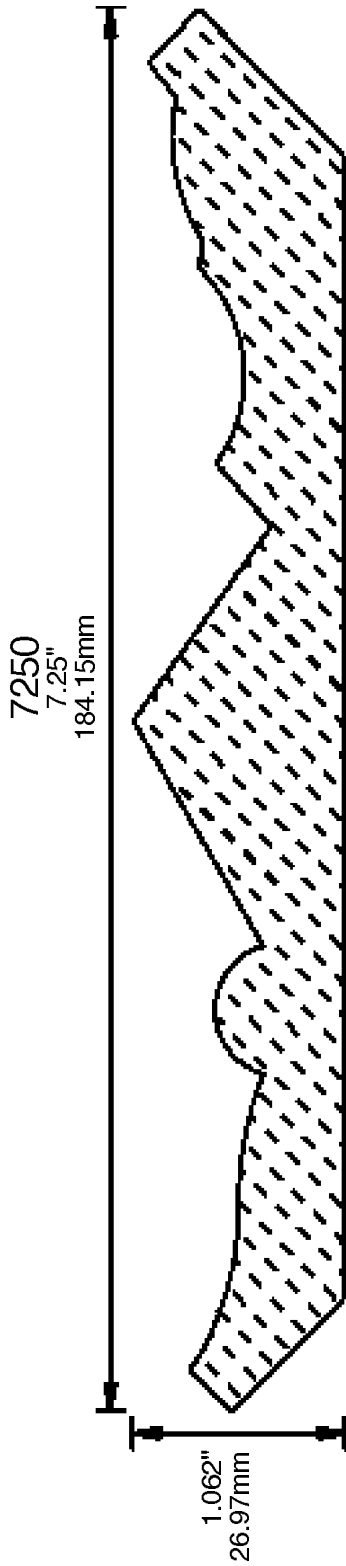

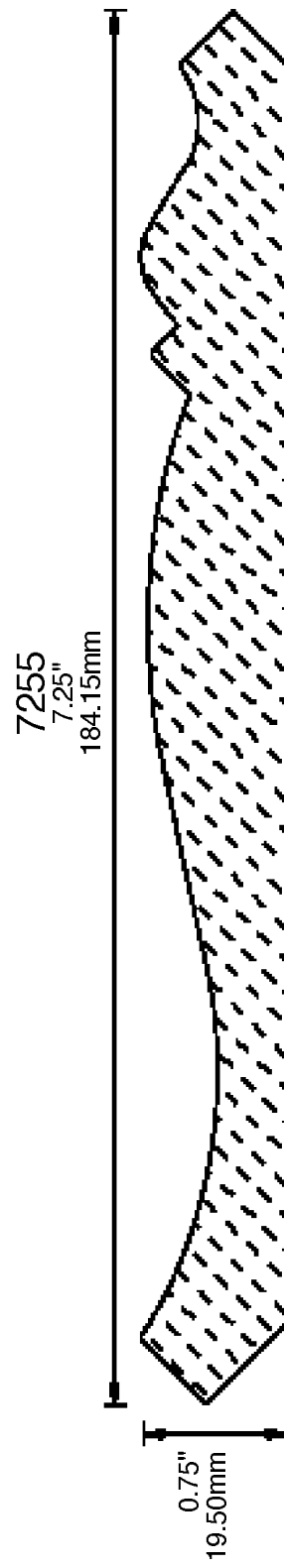
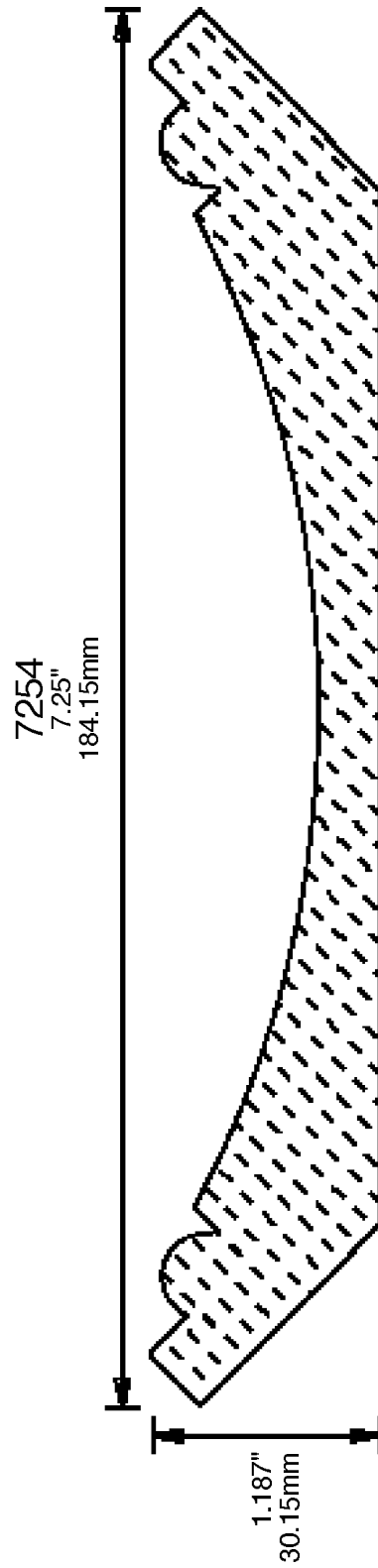
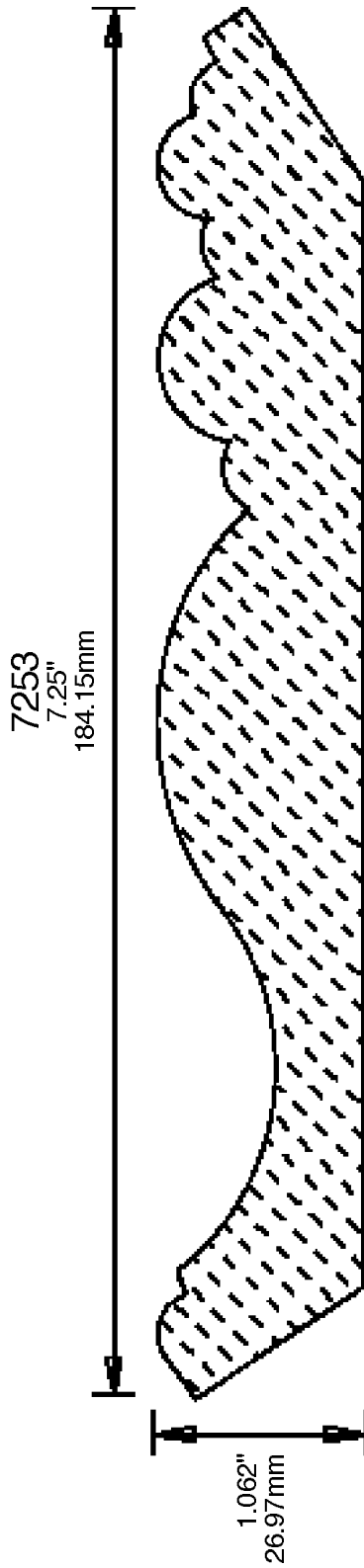

# WEINIG CROWN MOULDING PATTERNS

7256  
7.25"  
184.15mm

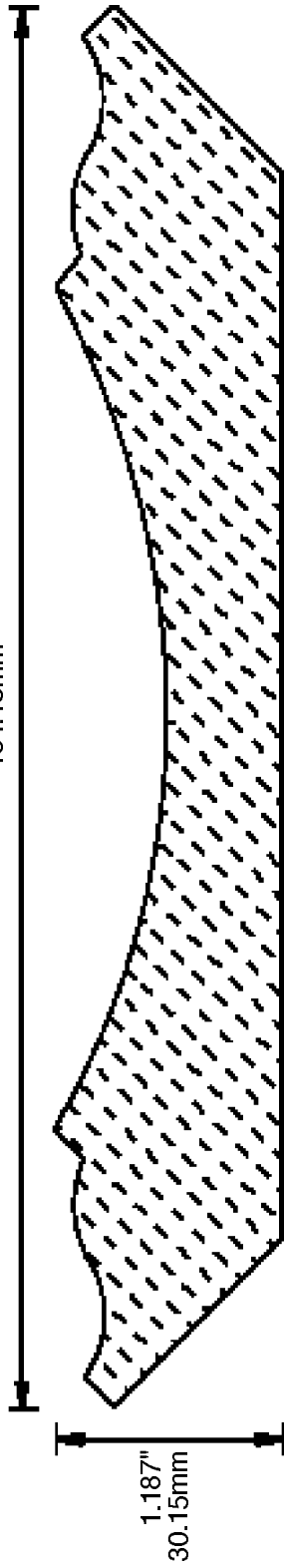

7371  
7.375"  
187.33mm

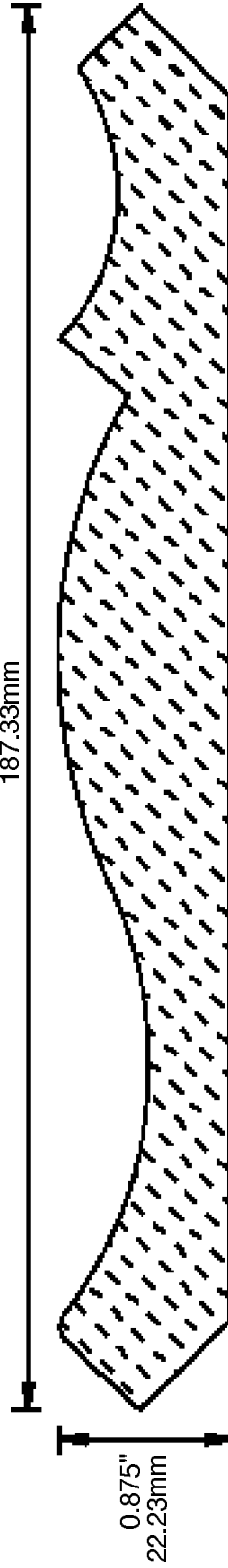

7372  
7.375"  
187.33mm

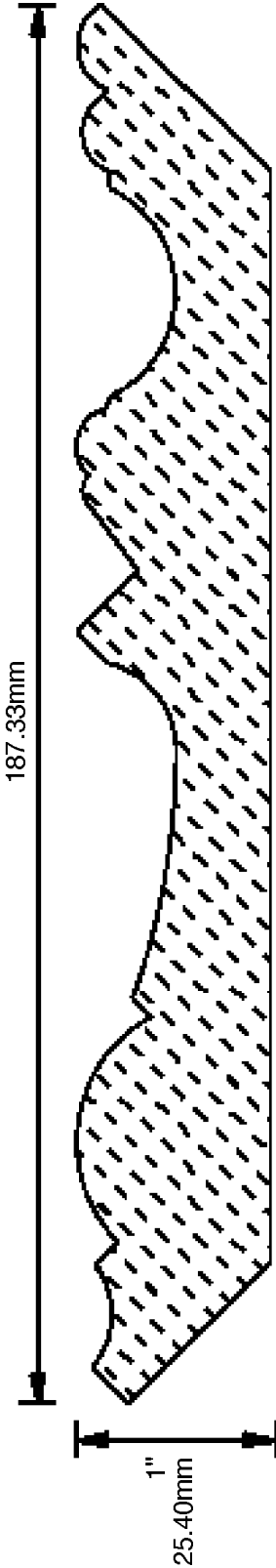



# WEINIG CROWN MOULDING PATTERNS

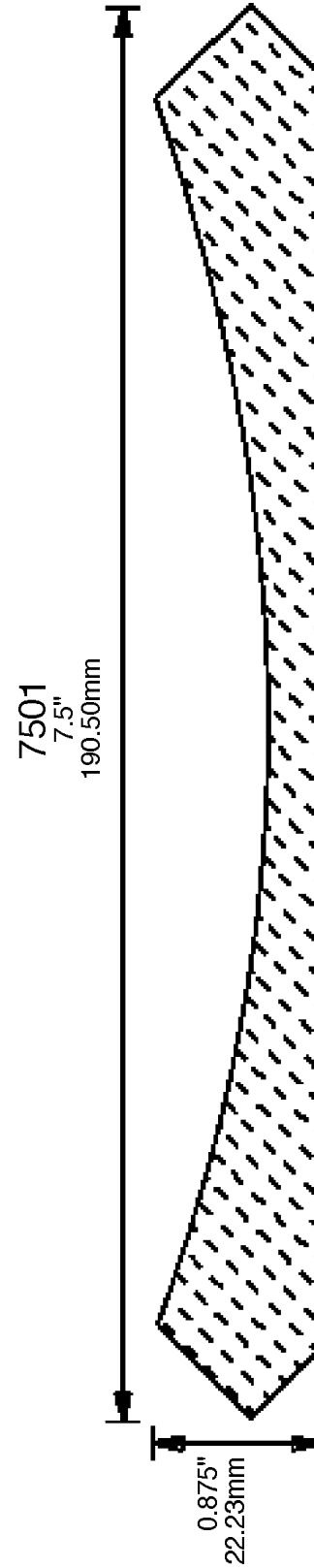
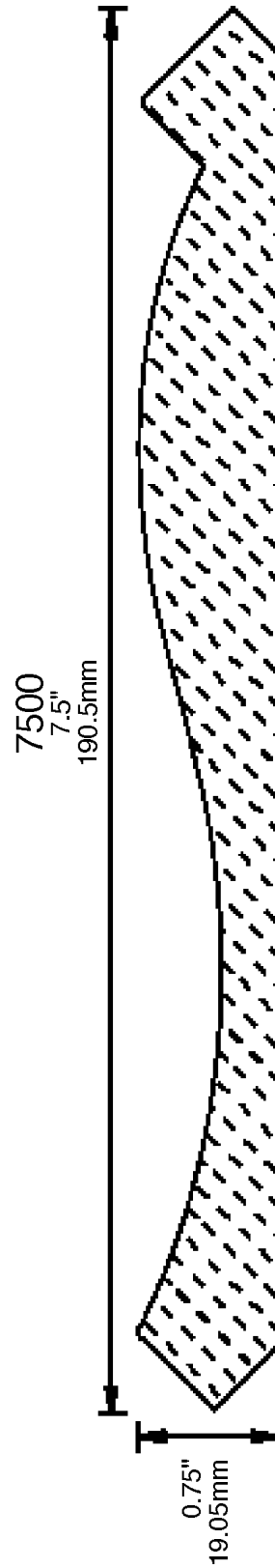
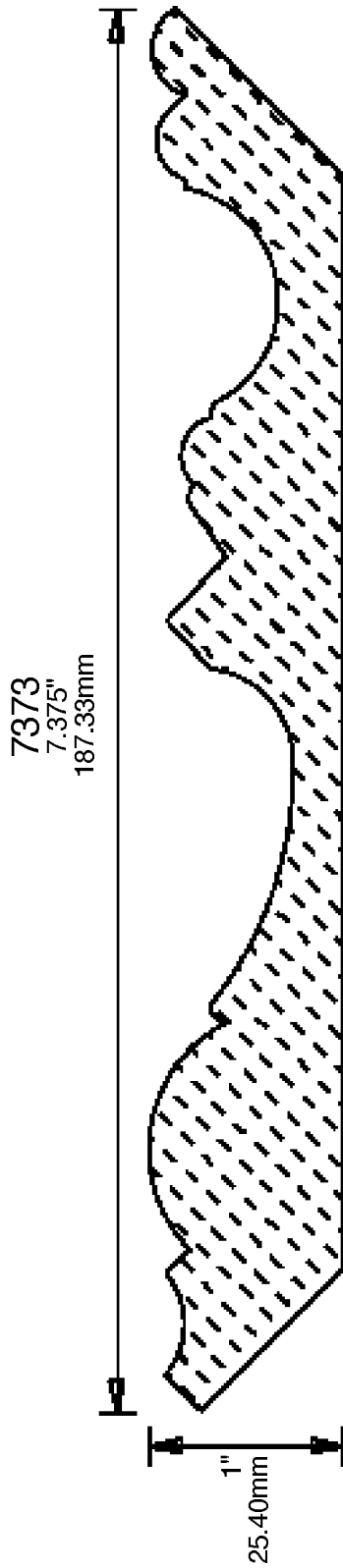

**PRINT  
THIS SECTION**

**RETURN TO  
Table of Contents**

# WEINIG CROWN MOULDING PATTERNS

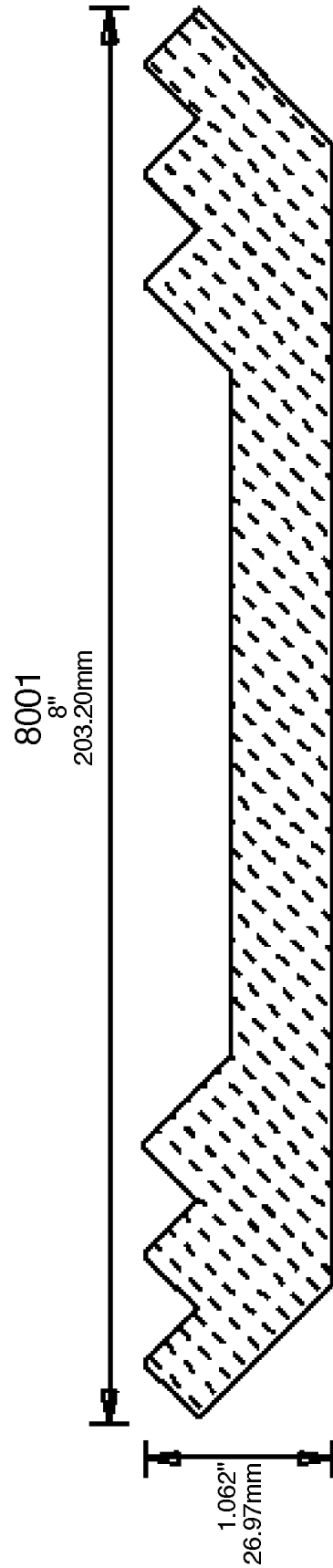
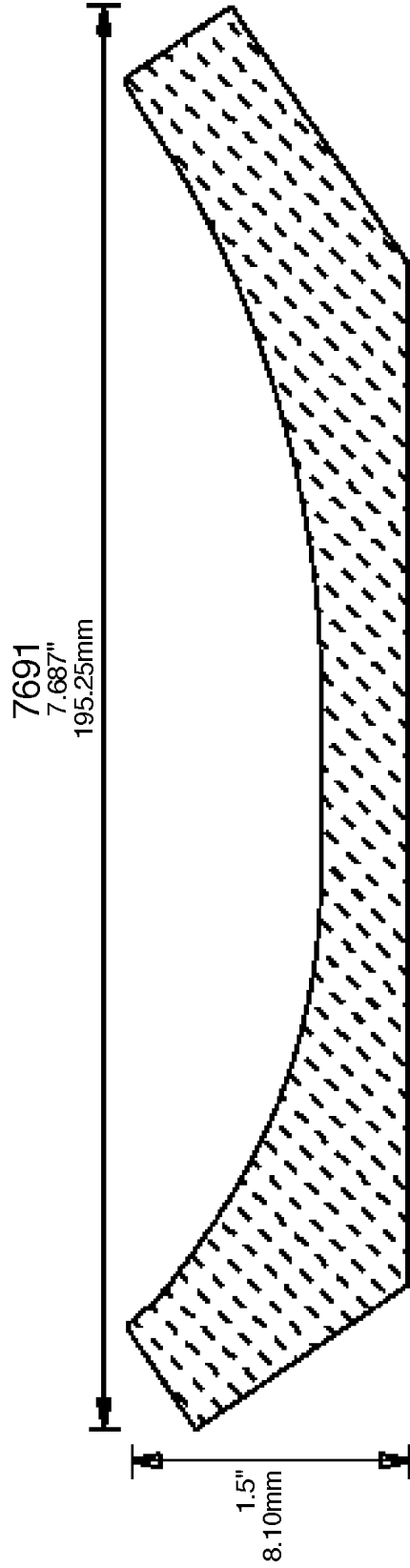
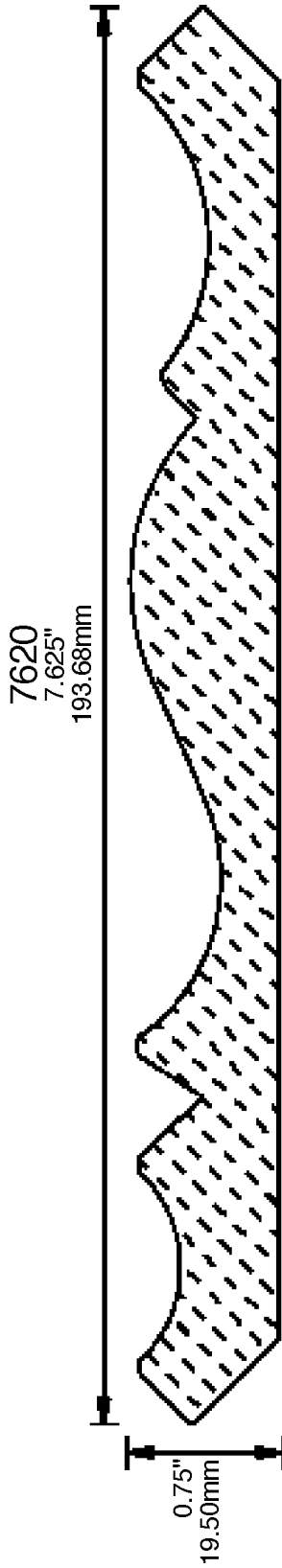

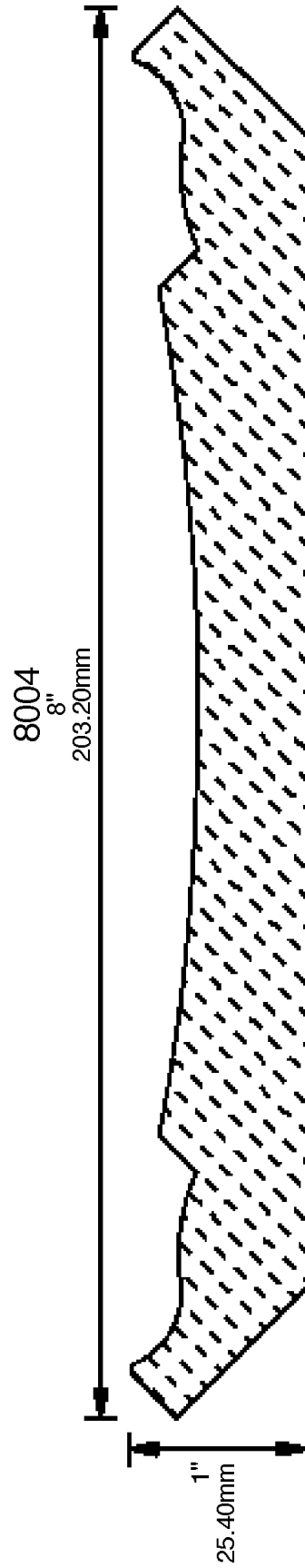
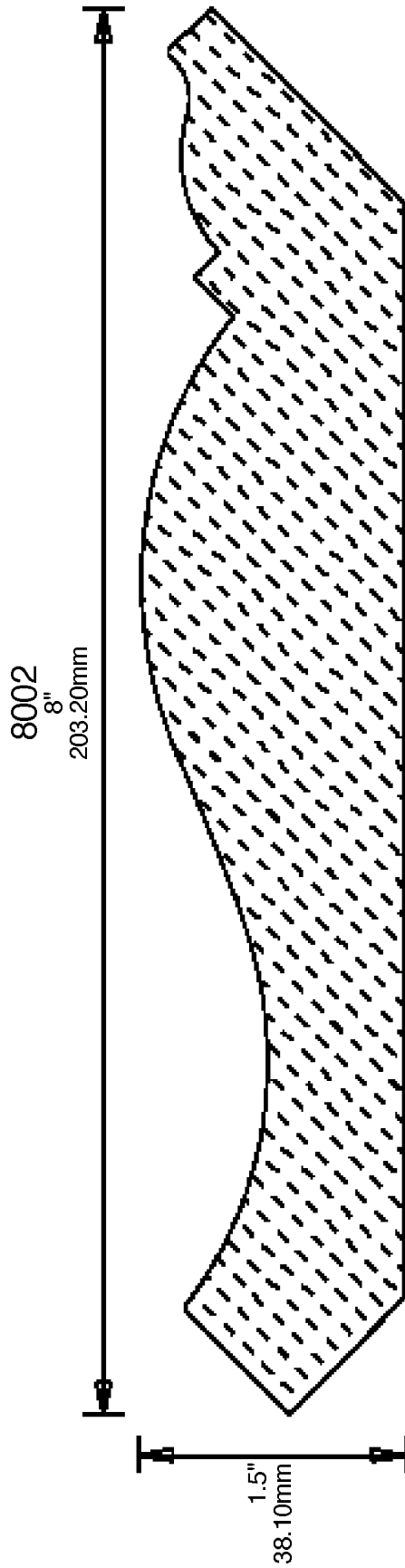

# WEINIG CROWN MOULDING PATTERNS

8005

8"

203.20mm

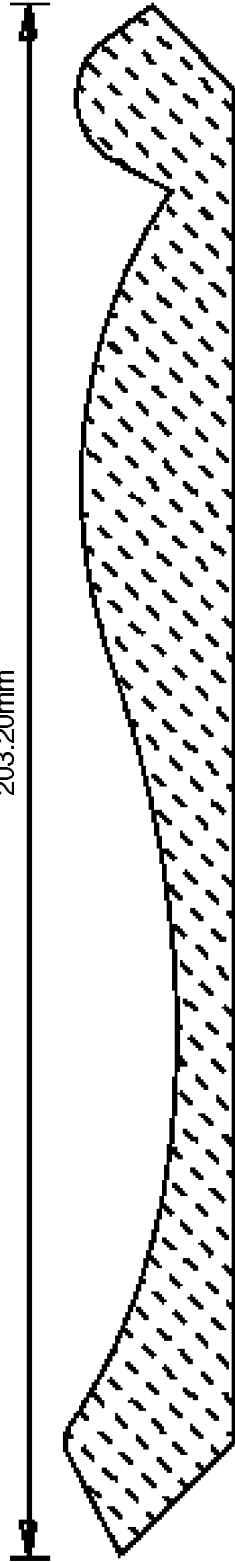

0.875"

22.23mm

8121

8.125"

206.38mm

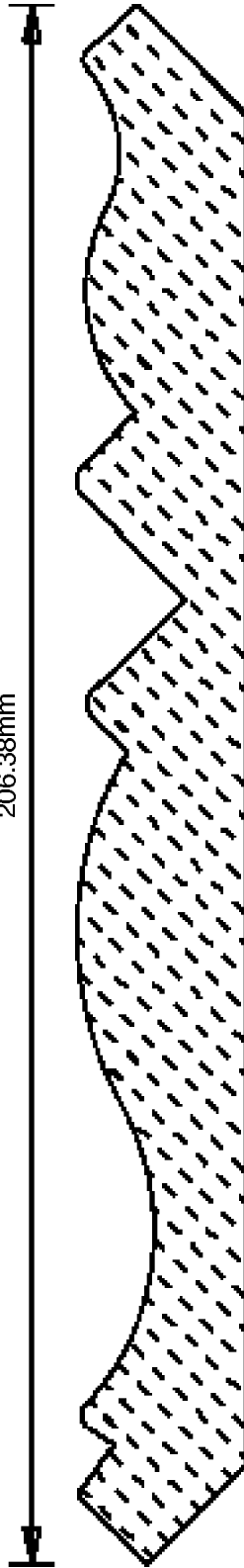

0.875"

22.23mm

8371

8.375"

212.73mm

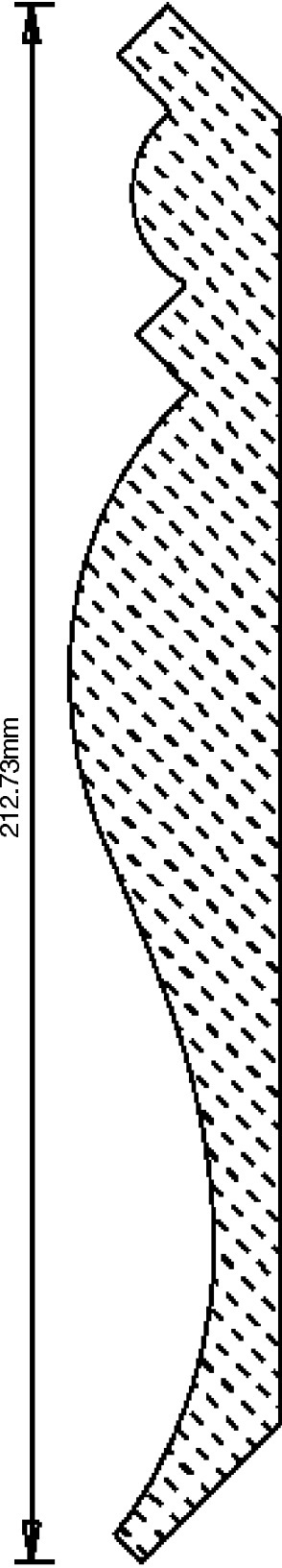

1.125"

28.58mm

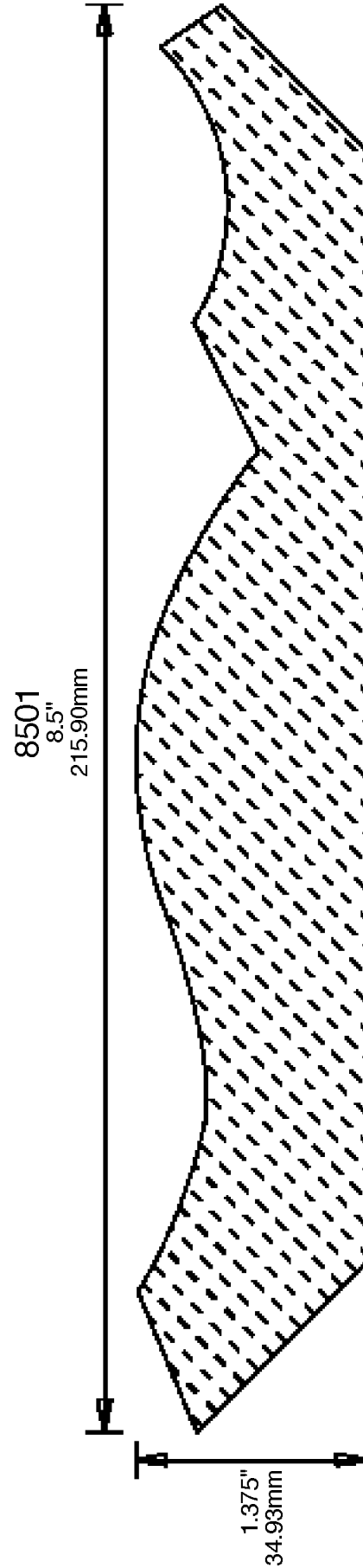
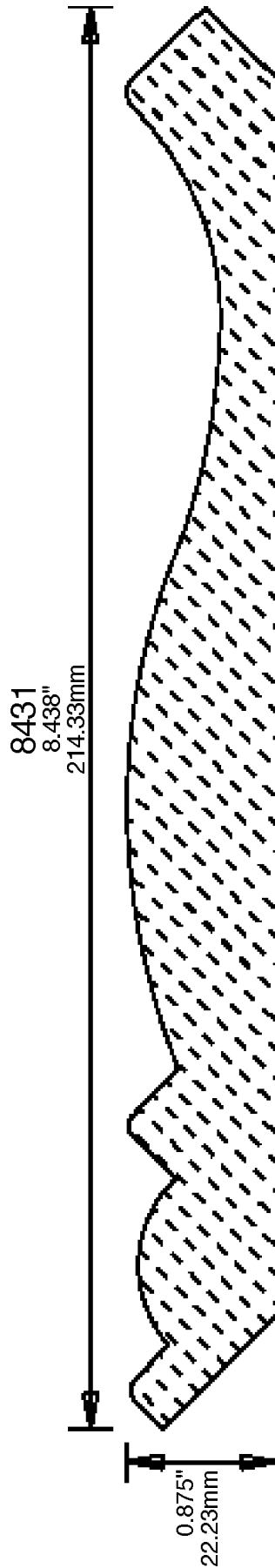

# WEINIG CROWN MOULDING PATTERNS

8502

8.5"

215.90mm

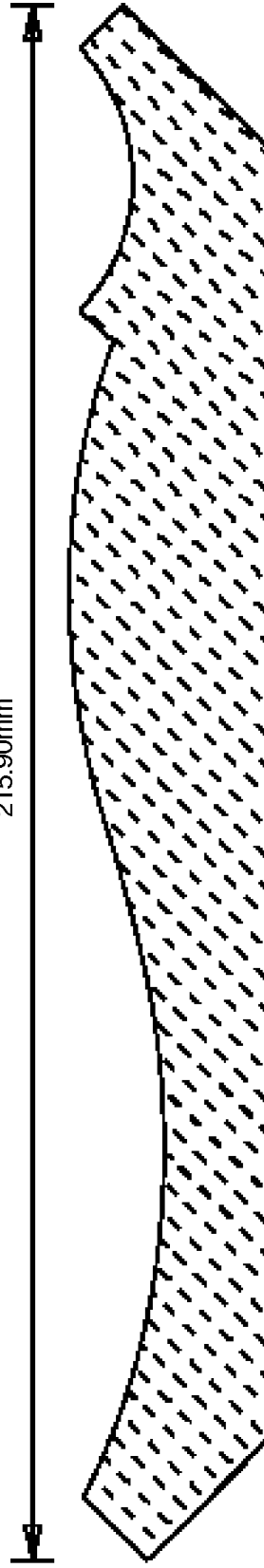

1.062"  
26.97mm

8503

8.5"

215.90mm

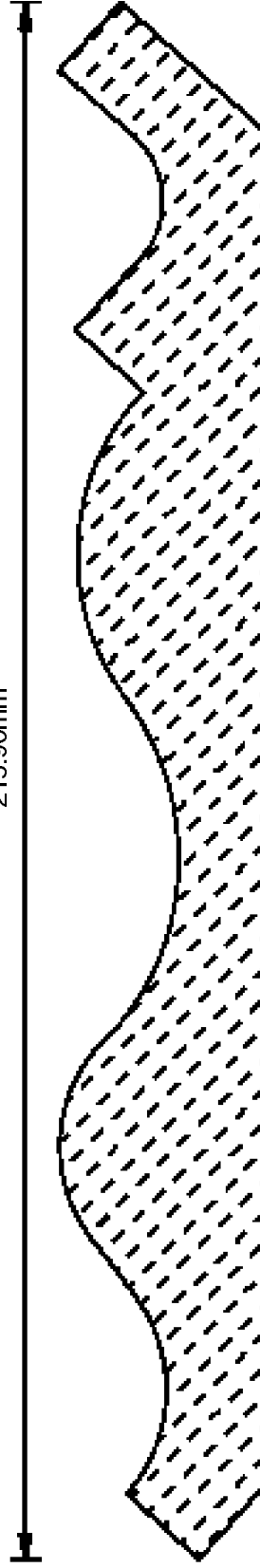

1.125"  
28.58mm

# WEINIG CROWN MOULDING PATTERNS

8750  
8.75"  
222.25mm

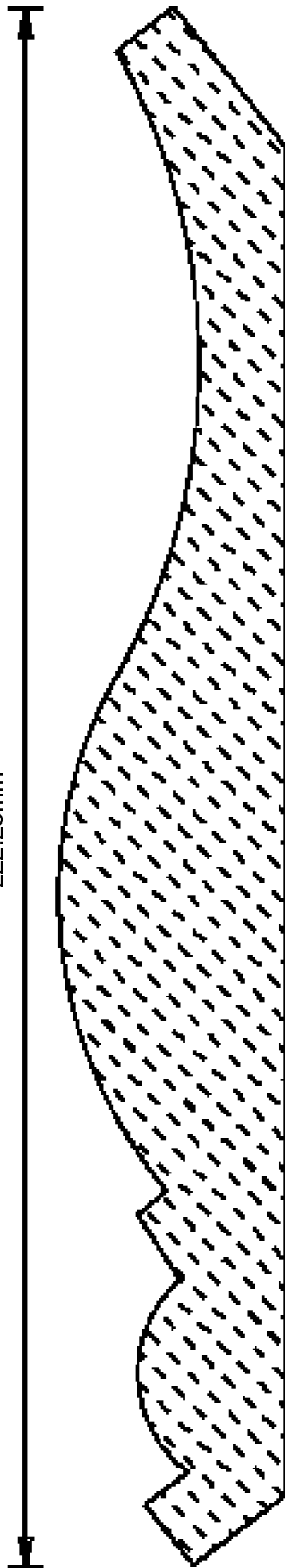

1.25"  
31.75mm

8751  
8.75"  
222.25mm

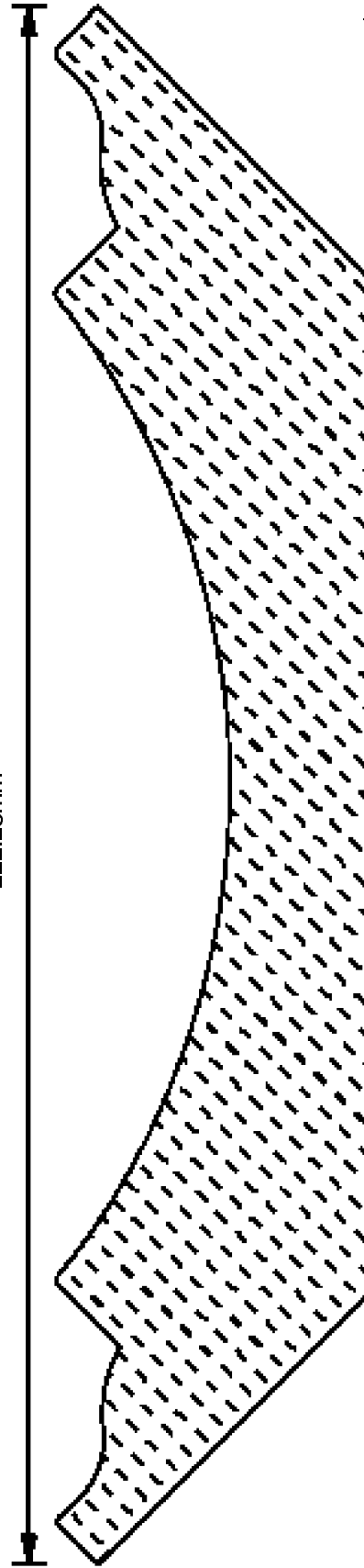

1.75"  
44.45mm

**PRINT  
THIS SECTION**

**RETURN TO  
Table of Contents**

# WEINIG CROWN MOULDING PATTERNS

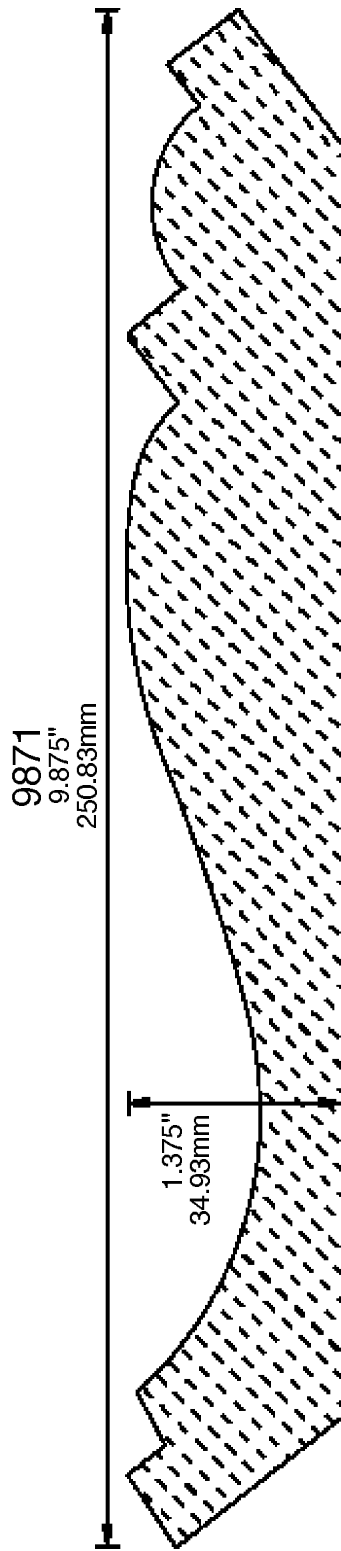

Not to Scale

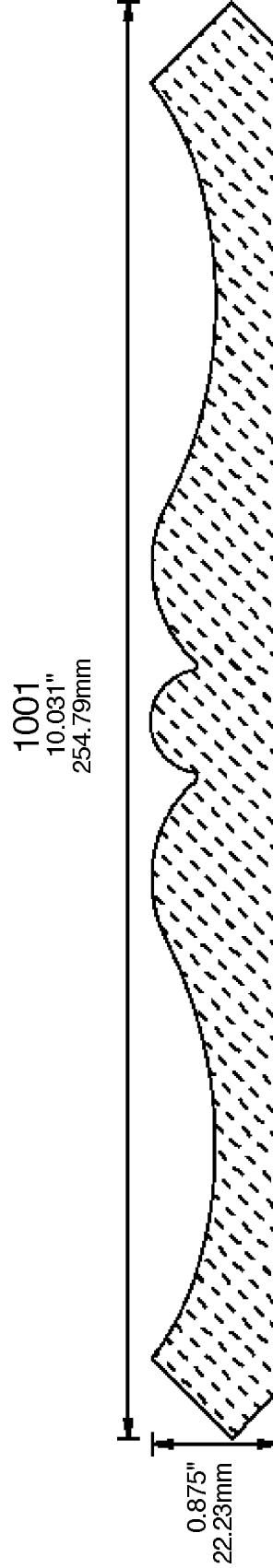

Not to Scale



# WEINIG CROWN MOULDING PATTERNS

12-372  
12.375"  
314.33mm

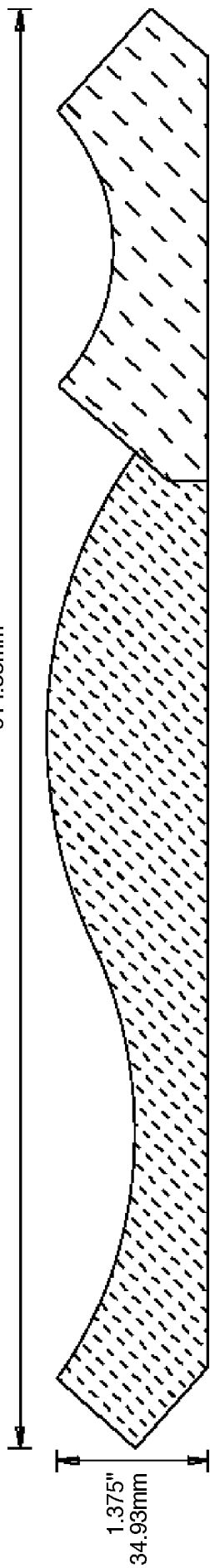

Not to Scale

1401  
14.757"  
374.83mm

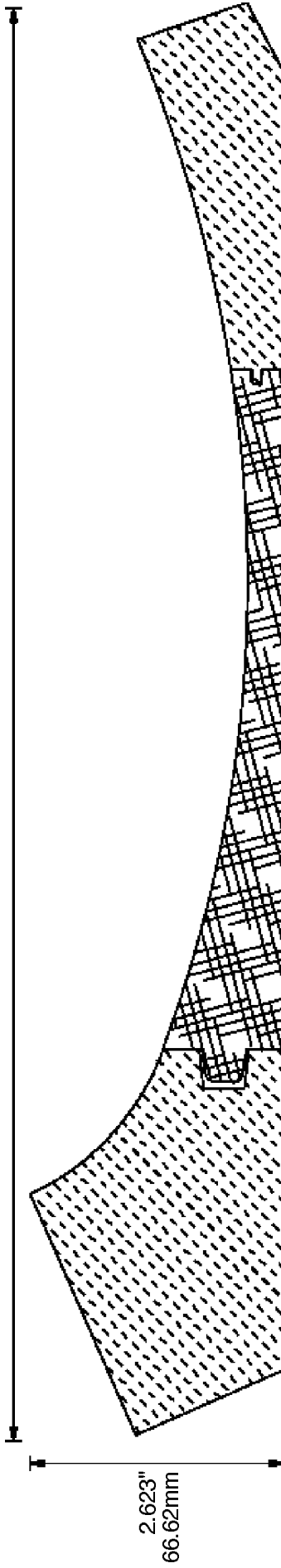

Not to Scale

**PRINT  
THIS SECTION**

**RETURN TO  
Table of Contents**

# WEINIG CASING AND BASE PATTERNS

Templates for all the casing and base patterns shown in this book are available through Weinig Custom Grinding Service.

In addition to these stock templates, Weinig Custom Grinding Service also will make custom-profile templates specifically for your needs. Each computer-generated template is made using the Michael Weinig Axial Constant System. We also offer the option of producing a hardened steel template.

Casing and base patterns are grouped together in this section. However, since some patterns can be used in a variety of ways, reference should also be made to chair rails, found in the section on Rail Moulding Patterns on page 3005. In the section on Casing and Base Patterns, refer also to fluted casings, which come with beads, coves, or both beads and coves.

## CASING AND BASE PATTERNS

Example:   CB 150 43 01

- CB   Identifies the product as a Michael Weinig Casing/Base Profile Pattern
- 150   Width of the profile as first 3 decimals. Many of the base patterns can be stretched or modified to alter the width. Often the same template can be used to run a variety of widths.
- 43   Thickness as first 2 decimals.
- 01   Profile number

Select the width of your Casing and Base Pattern from one of the following:

UP TO 2.5"

FROM 3.562" TO 4.25"

FROM 2.562" TO 3.25"

FROM 4.25" TO 4.875"

FROM 3.312" TO 3.5"

FROM 5" TO 5.5"

FROM 5.5" TO 9"

FLUTED CASINGS

# WEINIG CASING AND BASE PATTERNS

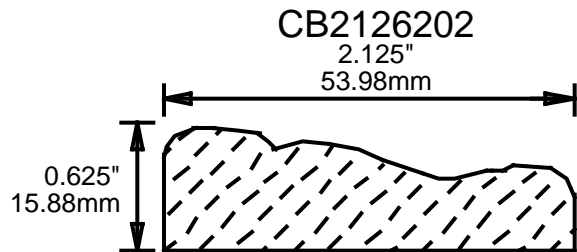
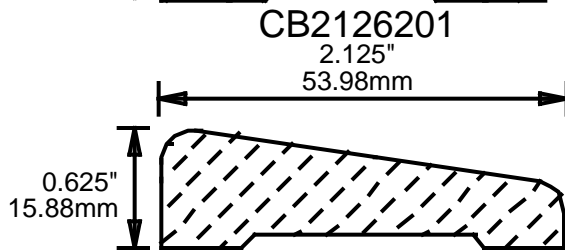
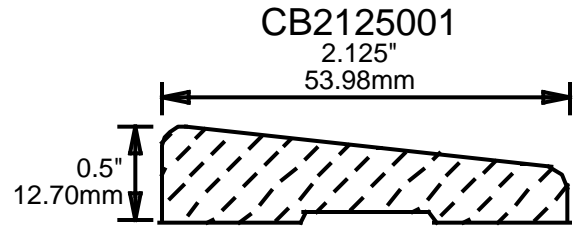
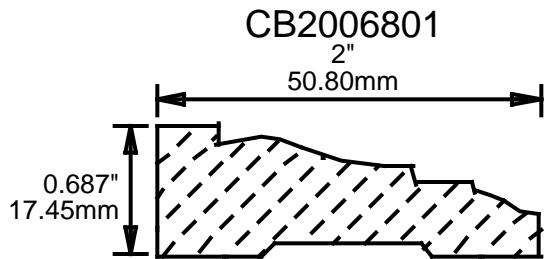
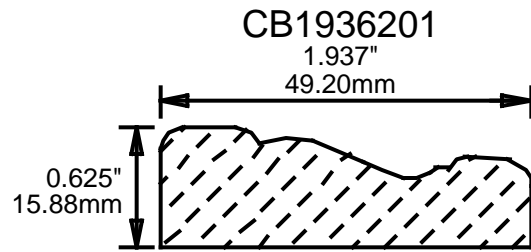
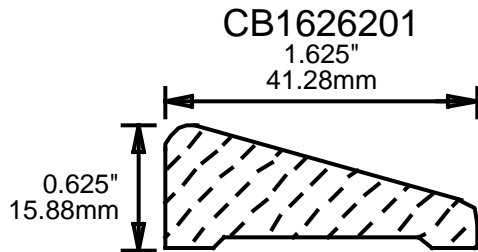
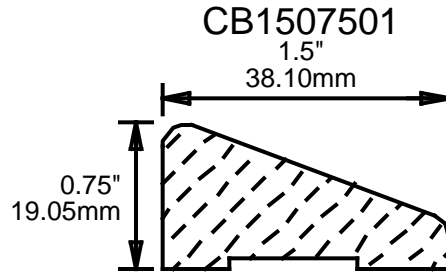
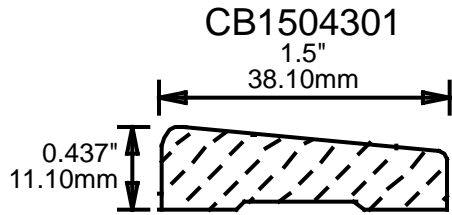

# WEINIG CASING AND BASE PATTERNS

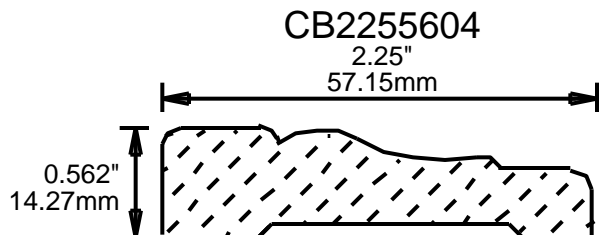
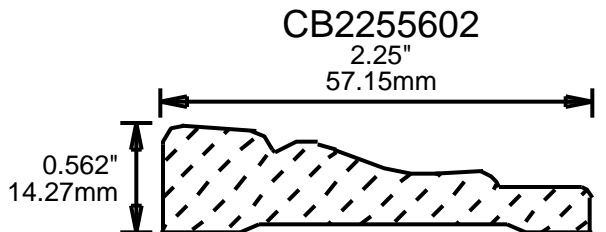
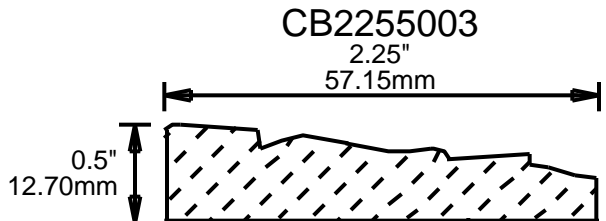
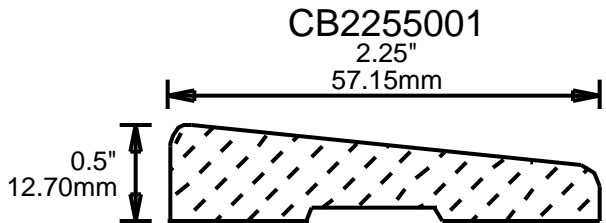
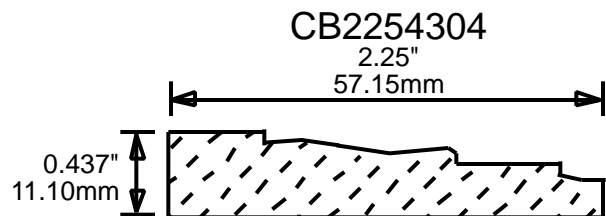
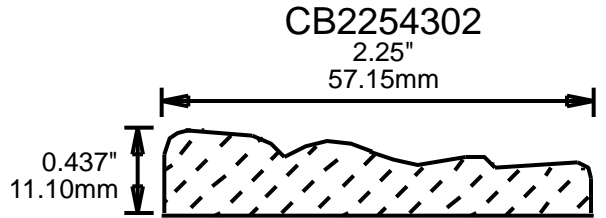
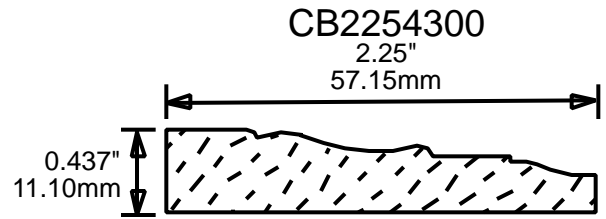
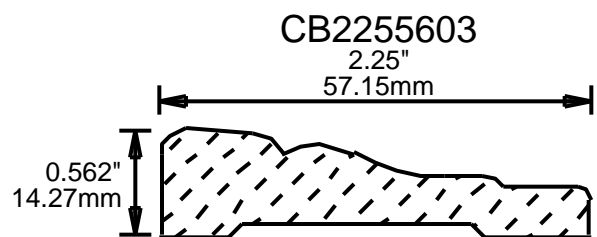
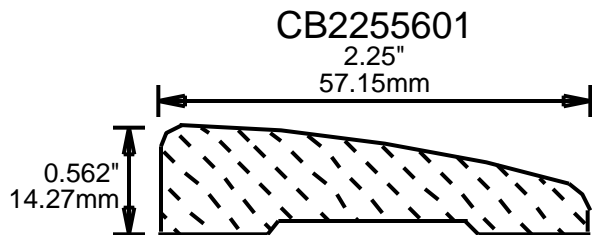
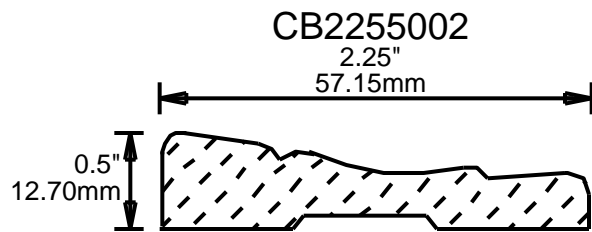
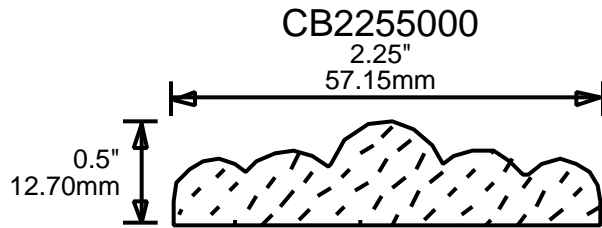
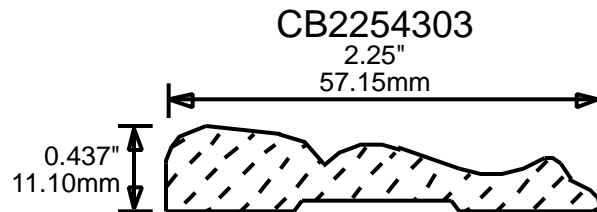
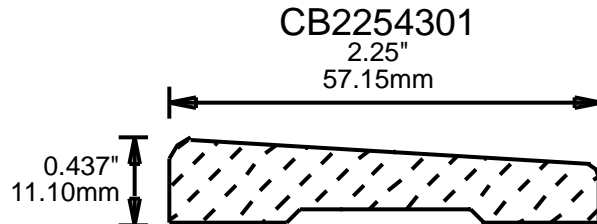
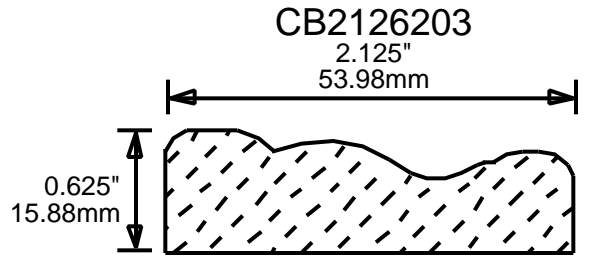

# WEINIG CASING AND BASE PATTERNS

CB2255605

2.25"  
57.15mm

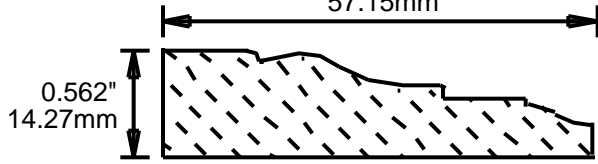

CB2255606

2.25"  
57.15mm

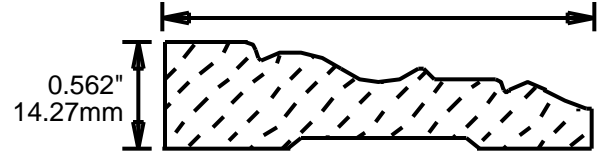

CB2255607

2.25"  
57.15mm

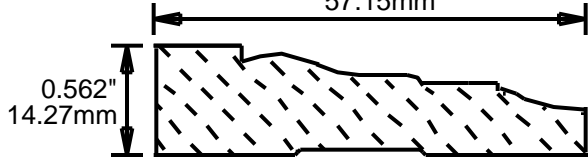

CB2255608

2.25"  
57.15mm

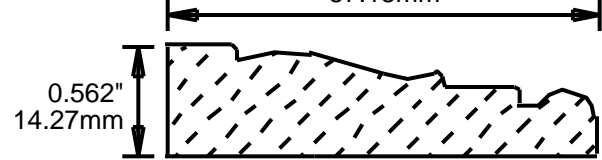

CB2255609

2.25"  
57.15mm

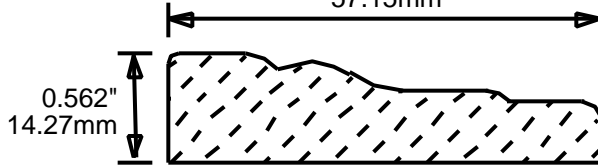

CB2256200

2.25"  
57.15mm

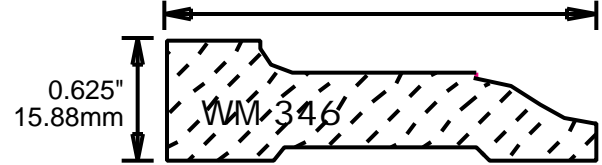

CB2256201

2.25"  
57.15mm

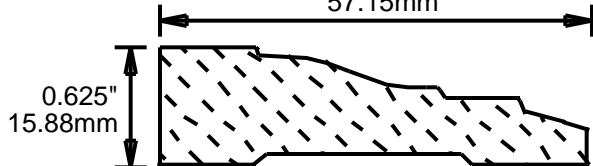

CB2256202

2.25"  
57.15mm

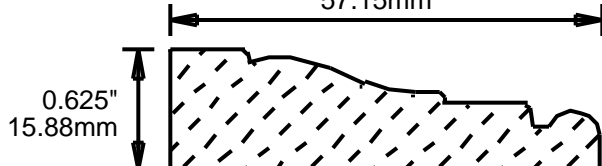

CB2256203

2.25"  
57.15mm

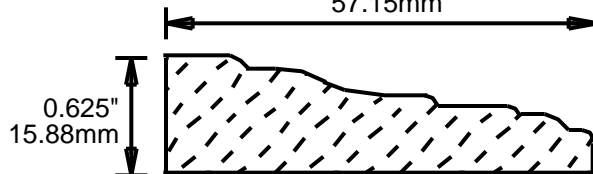

CB2256204

2.25"  
57.15mm

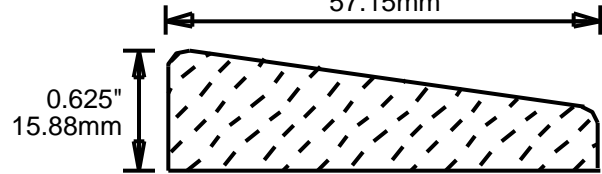

CB2256205

2.25"  
57.15mm

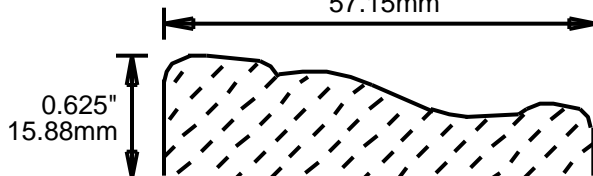

CB2256206

2.25"  
57.15mm

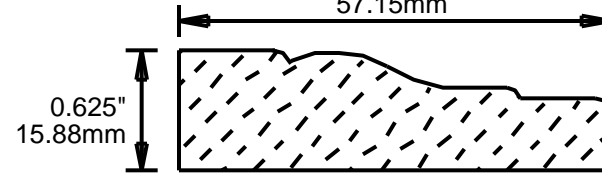

# WEINIG CASING AND BASE PATTERNS

CB2256207

2.25"  
57.15mm

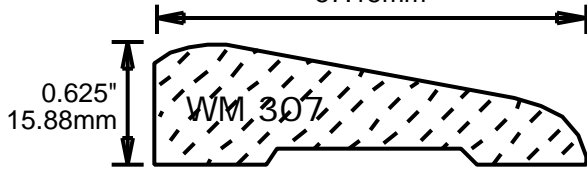

CB2256208

2.25"  
57.15mm

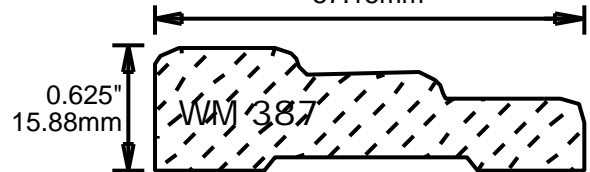

CB2256800

2.25"  
57.15mm

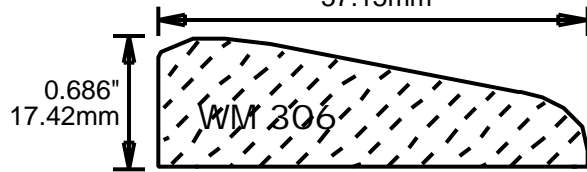

CB2256801

2.25"  
57.15mm

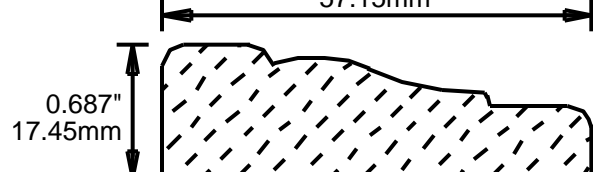

CB2256802

2.25"  
57.15mm

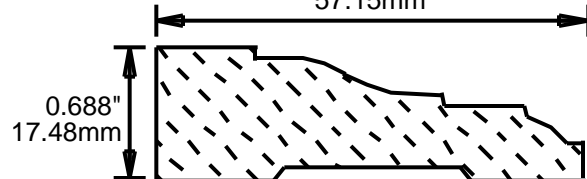

CB2256803

2.25"  
57.15mm

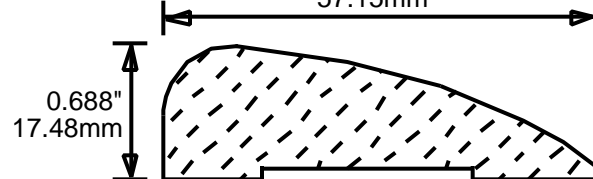

CB2256804

2.25"  
57.15mm

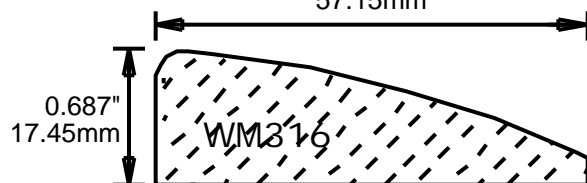

CB2256805

2.25"  
57.15mm

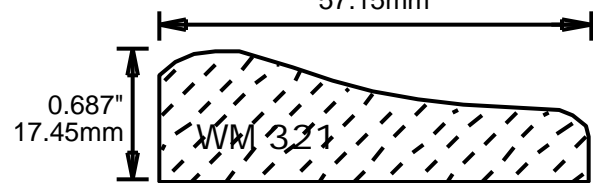

CB2256806

2.25"  
57.15mm

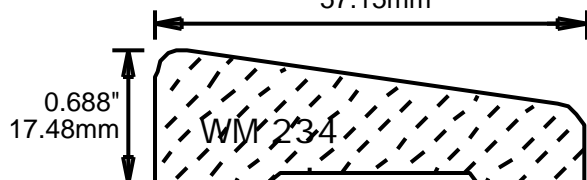

CB2256807

2.25"  
57.15mm

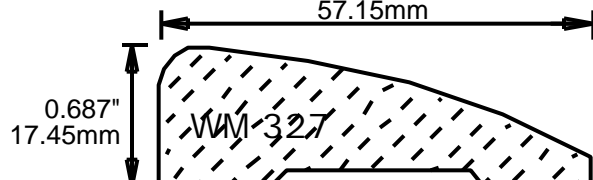

CB2256808

2.25"  
57.15mm

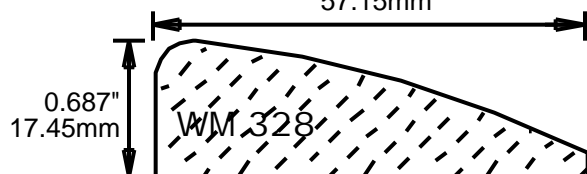

CB2256809

2.25"  
57.15mm

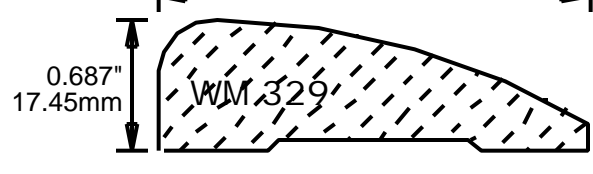

# WEINIG CASING AND BASE PATTERNS

**CB2256810**

2.25"

57.15mm

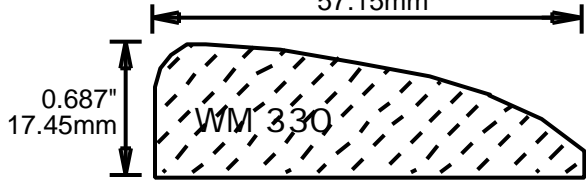

**CB2256811**

2.25"

57.15mm

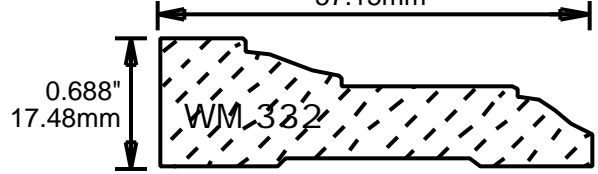

**CB2256812**

2.25"

57.15mm

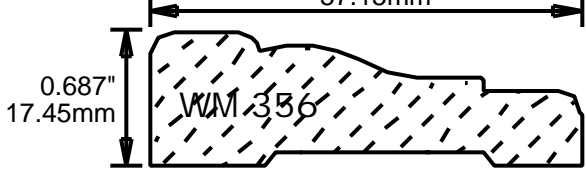

**CB2256813**

2.25"

57.15mm



**CB2256814**

2.25"

57.15mm

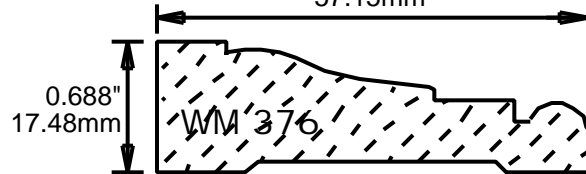

**CB2256815**

2.25"

57.15mm



**CB2257501**

2.25"

57.15mm

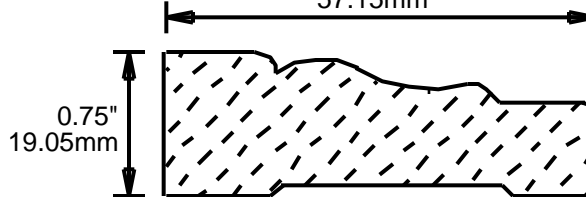

**CB2257502**

2.25"

57.15mm

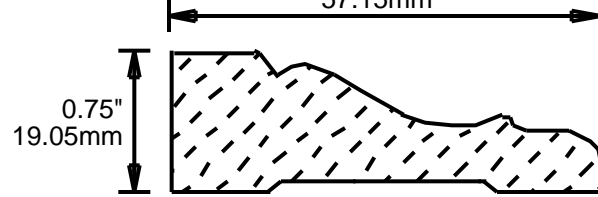

**CB2317501**

2.312"

58.72mm

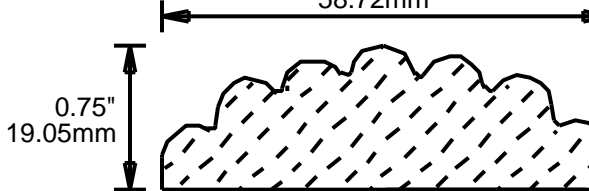

**CB2377501**

2.375"

60.33mm

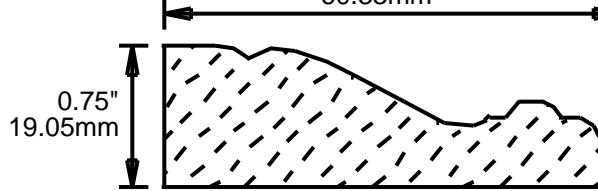

**CB2377502**

2.375"

60.33mm

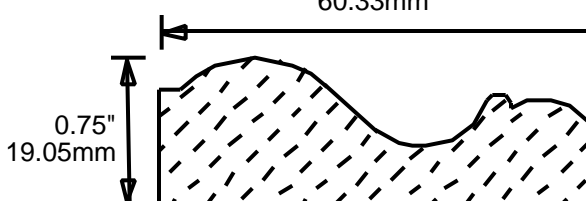

**CB2437501**

2.437"

61.90mm

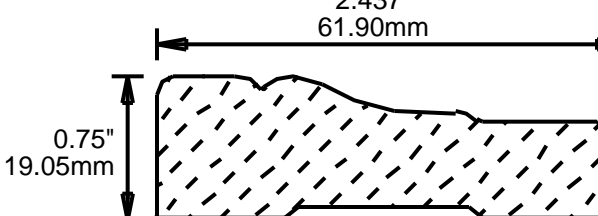

# WEINIG CASING AND BASE PATTERNS

CB2505001

2.5"

63.50mm



CB2505601

2.5"

63.50mm



CB2506200

2.25"

57.15mm

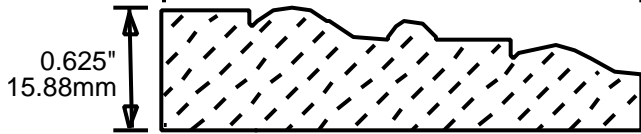

CB2506201

2.5"

63.50mm

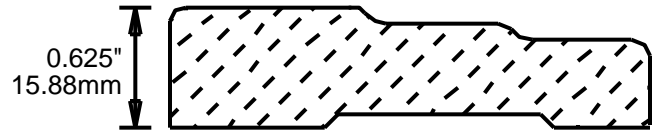

CB2506202

2.5"

63.50mm

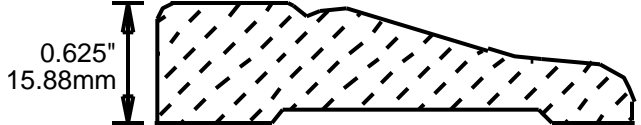

CB2506203

2.5"

63.50mm



CB2506204

2.5"

63.50mm

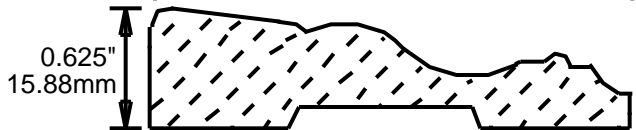

CB2506800

2.5"

63.50mm

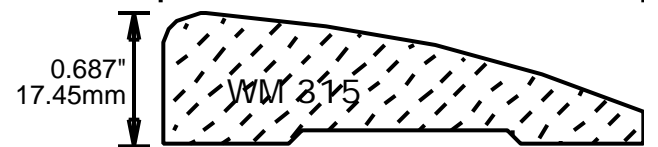

CB2506801

2.5"

63.50mm

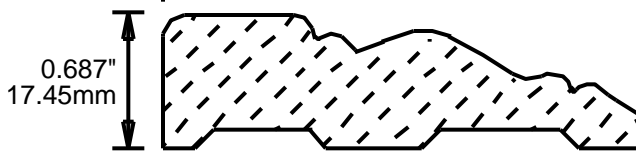

CB2506802

2.5"

63.50mm

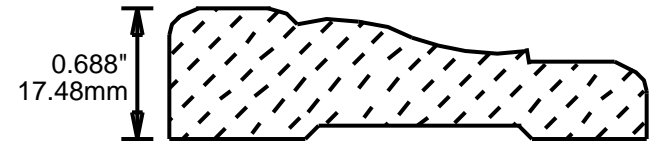

CB2506803

2.5"

63.50mm

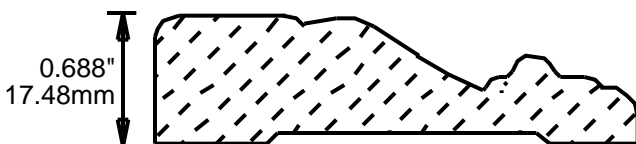

CB2506804

2.5"

63.50mm





# WEINIG CASING AND BASE PATTERNS

CB2506805

2.5"  
63.50mm

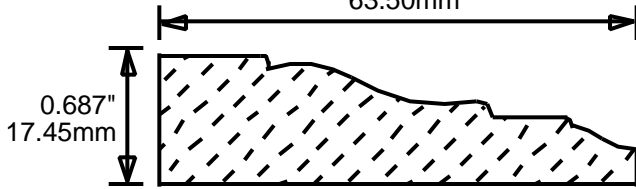

CB2506807

2.5"  
63.50mm

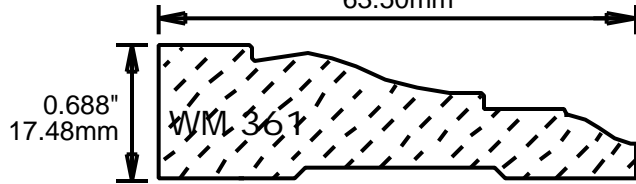

CB2506806

2.5"  
63.50mm

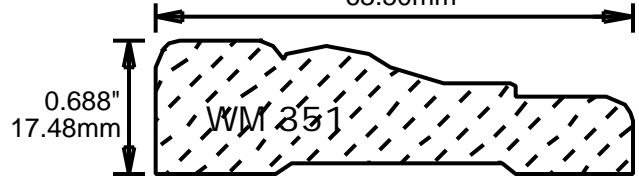

CB2506808

2.5"  
63.50mm

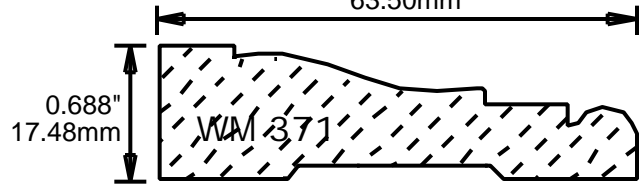

CB2506809

2.5"  
63.50mm

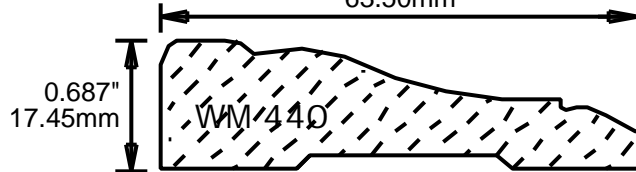

CB2507501

2.5"  
63.50mm

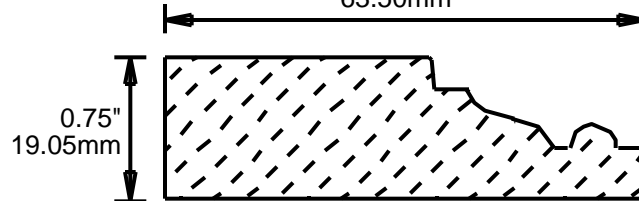

CB2507502

2.5"  
63.50mm

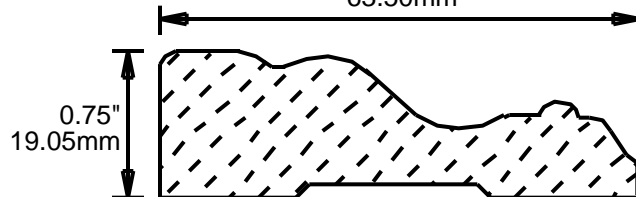

CB2507503

2.5"  
63.50mm

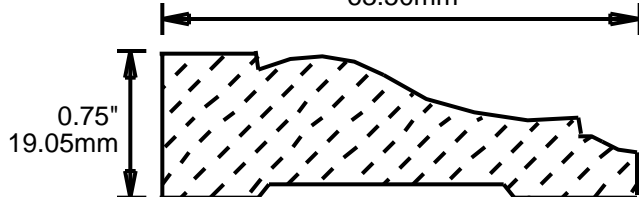

CB2507504

2.5"  
63.50mm

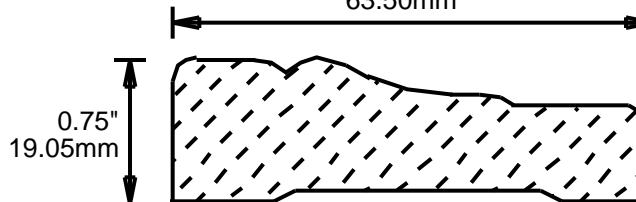

CB2507505

2.5"  
63.50mm

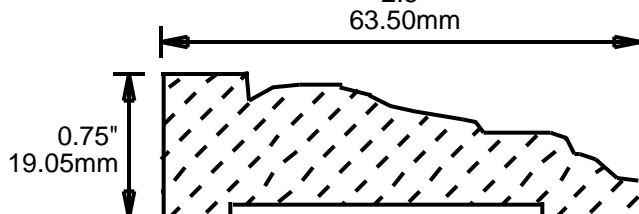

CB2507506

2.5"  
63.50mm

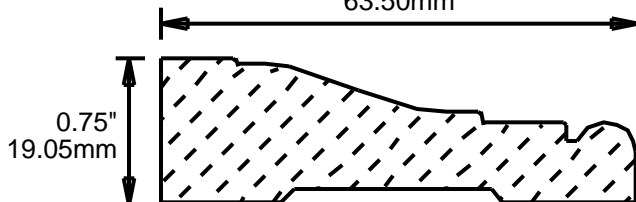

CB2507507

2.5"  
63.50mm

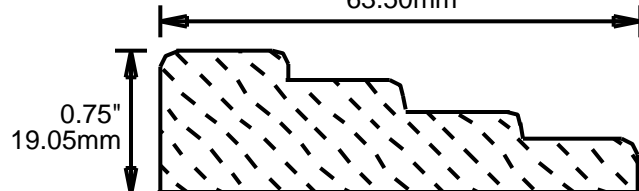

# WEINIG CASING AND BASE PATTERNS

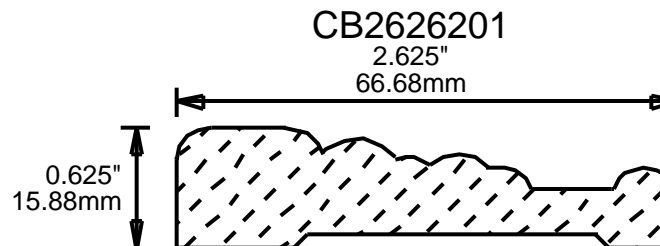
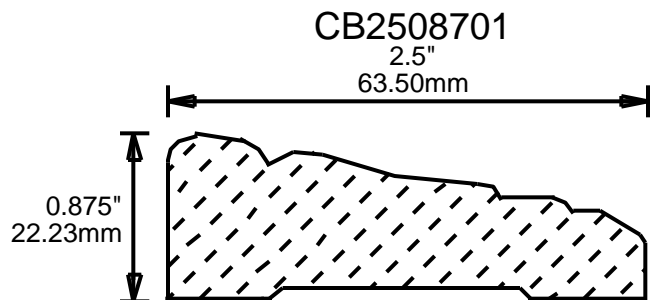
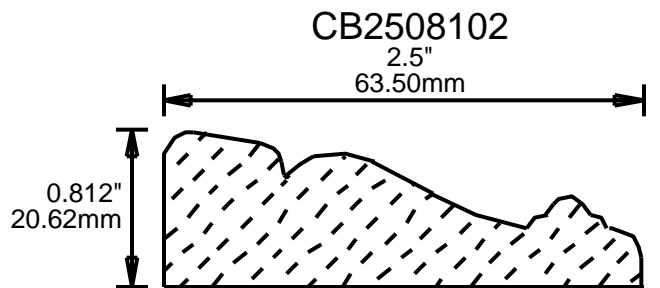
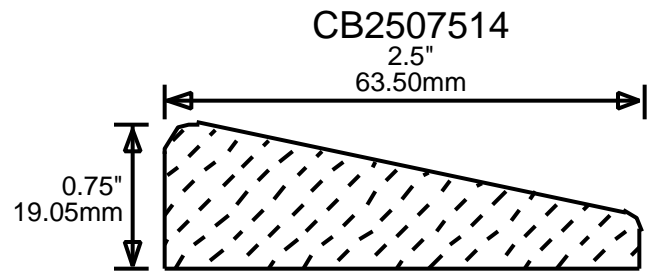
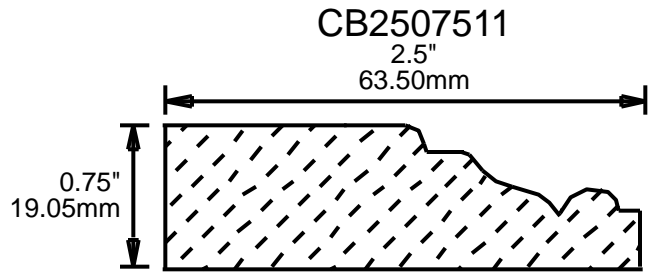
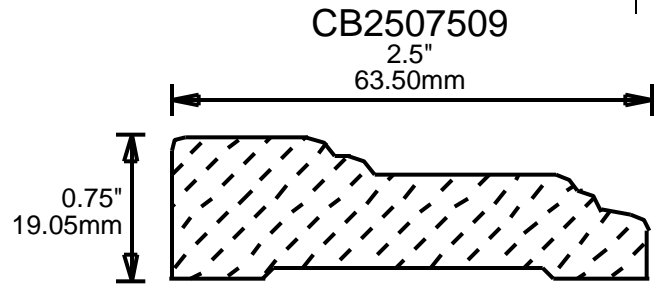
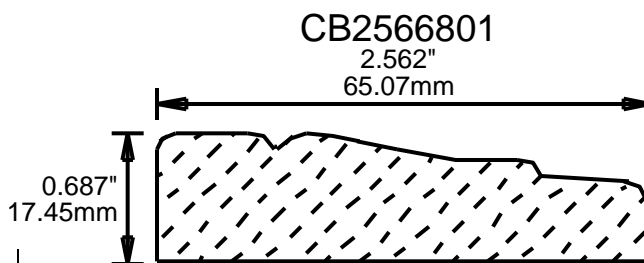
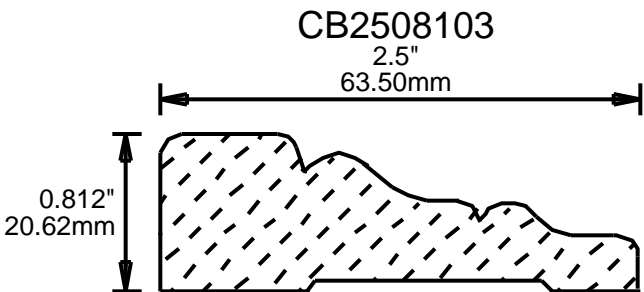
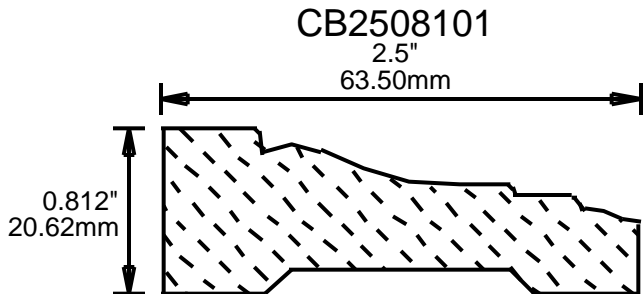
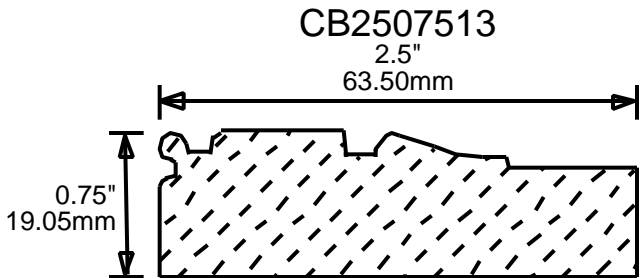
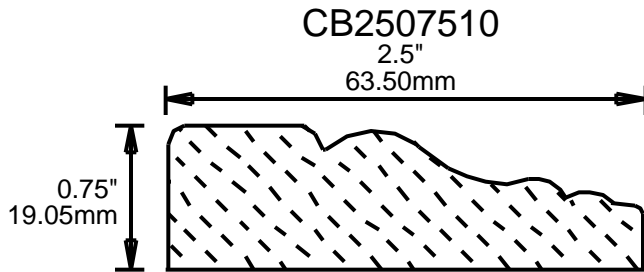
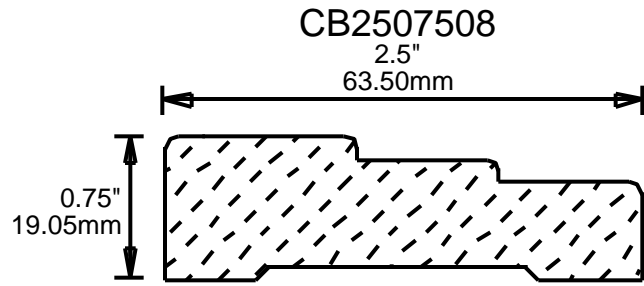

# WEINIG CASING AND BASE PATTERNS

**CB2627501**

2.625"  
66.68mm

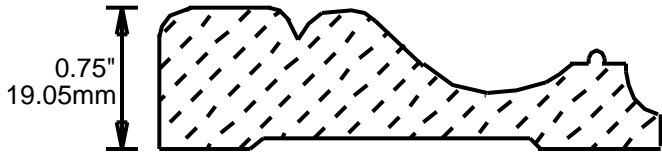

**CB2686801**

2.687"  
68.25mm

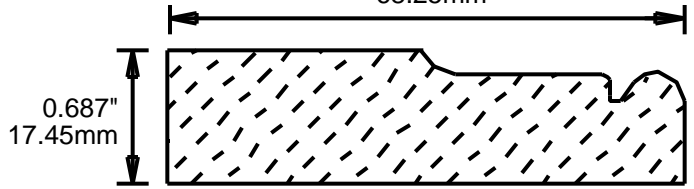

**CB2751000**

2.75"  
69.85mm

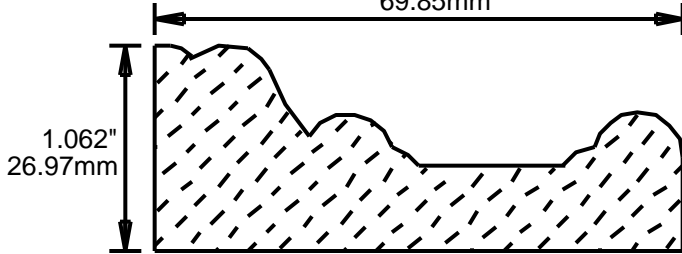

**CB2755601**

2.75"  
69.85mm

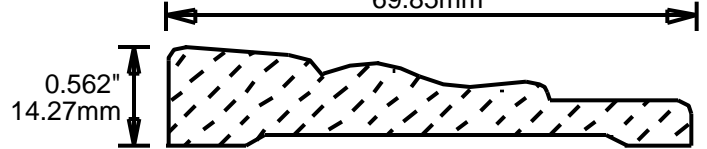

**CB2755602**

2.75"  
69.85mm

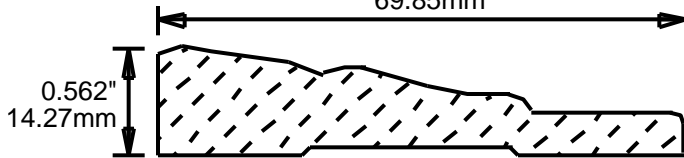

**CB2755603**

2.75"  
69.85mm

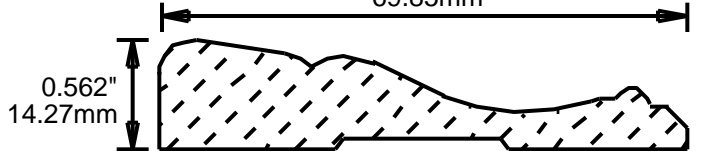

**CB2757500**

2.75"  
69.85mm

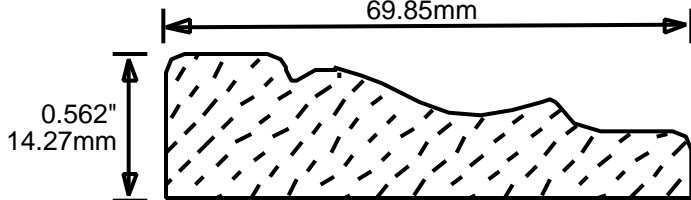

**CB2757501**

2.75"  
69.85mm

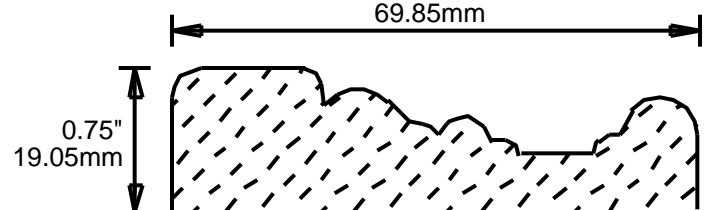

**CB2757502**

2.75"  
69.85mm

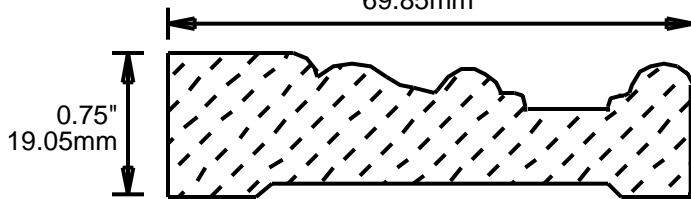

**CB2757503**

2.75"  
69.85mm

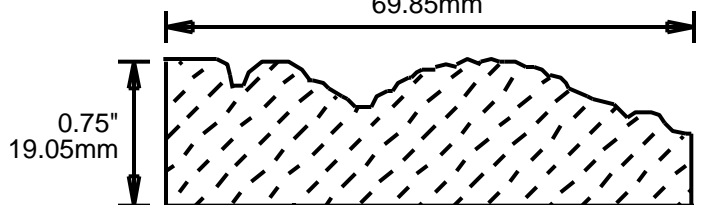

**CB2757504**

2.75"  
69.85mm



**CB2757505**

2.75"  
69.85mm

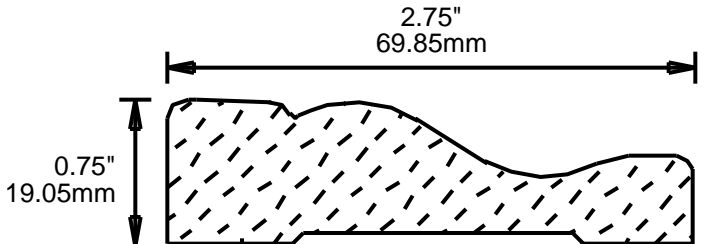

# WEINIG CASING AND BASE PATTERNS

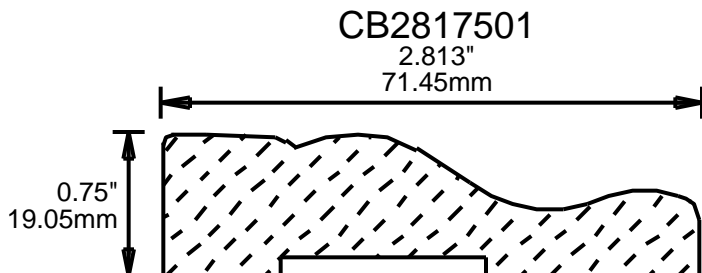
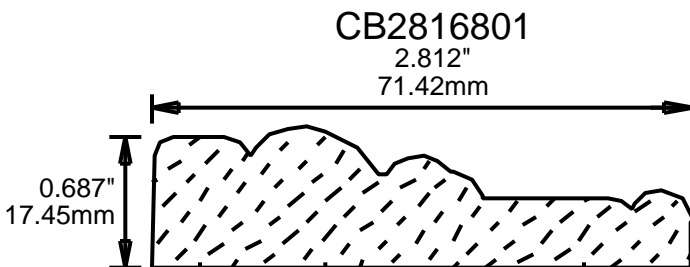
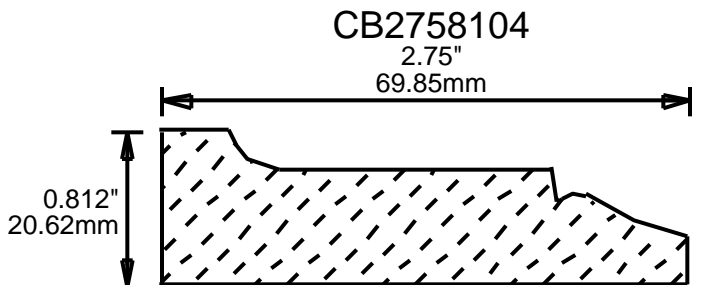
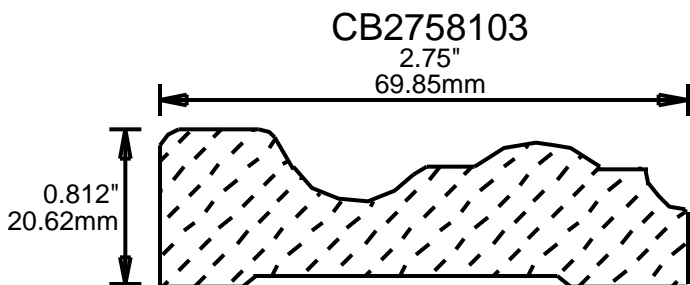
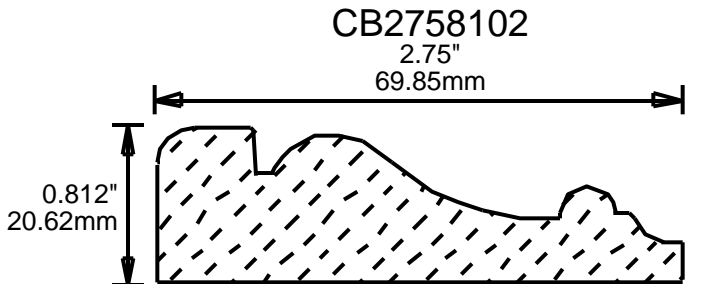
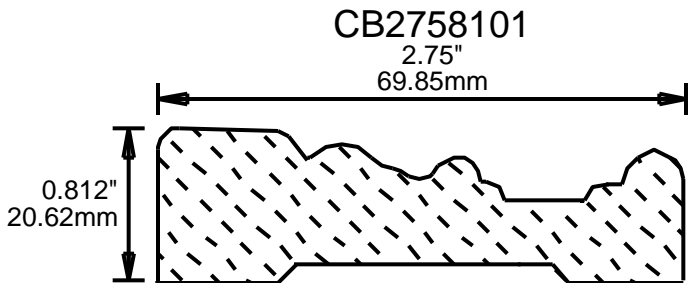
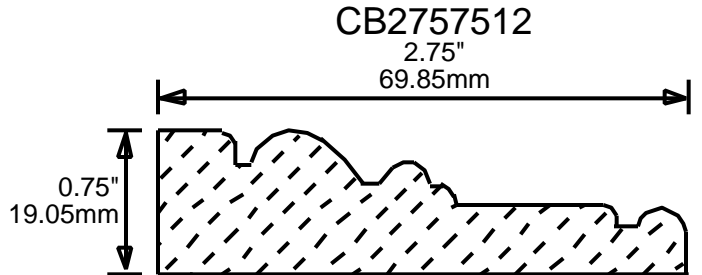
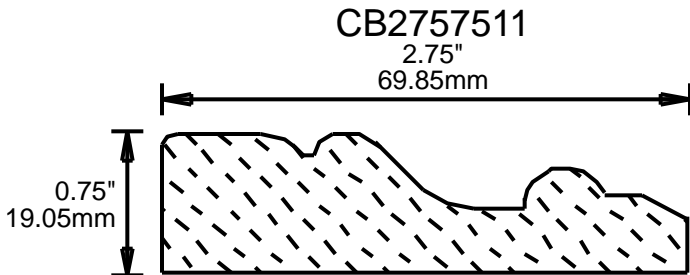
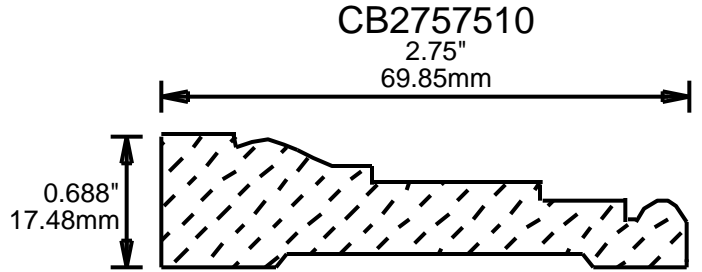
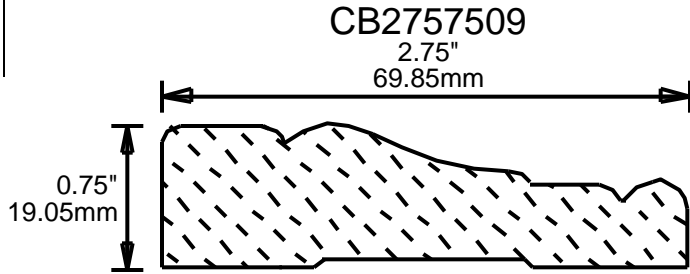
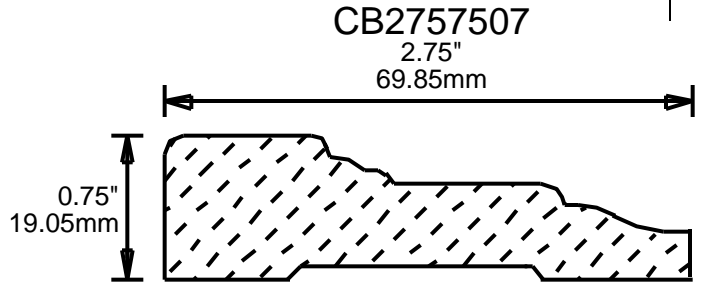
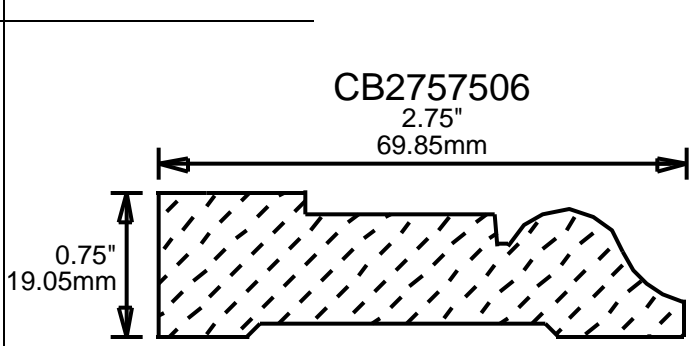

# WEINIG CASING AND BASE PATTERNS

**CB2877501**

2.875"  
73.03mm

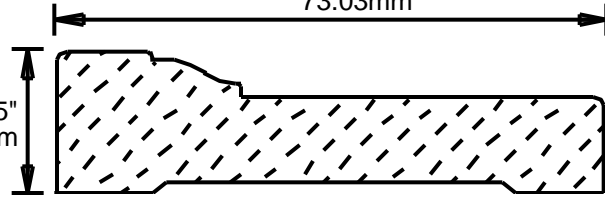

**CB2876201**

2.875"  
73.03mm

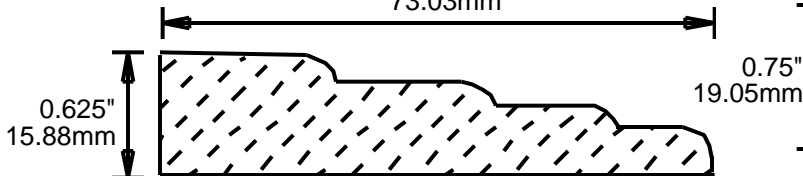

**CB2937501**

2.937"  
74.60mm

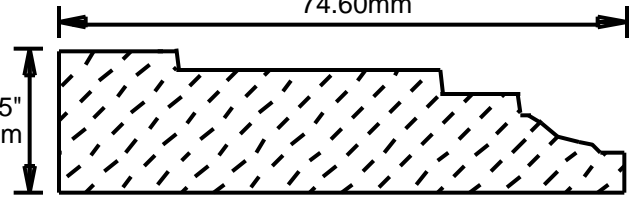

**CB2936201**

2.937"  
74.60mm

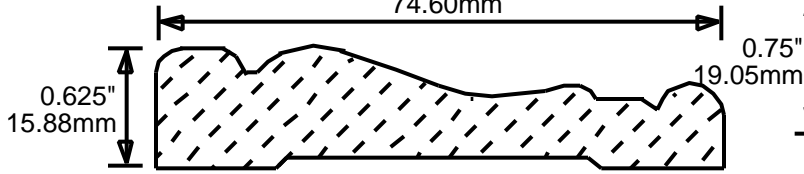

**CB3006201**

3"  
76.20mm

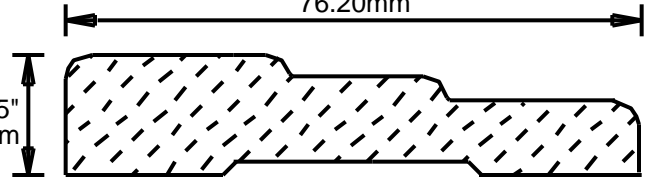

**CB3001201**

3"  
76.20mm

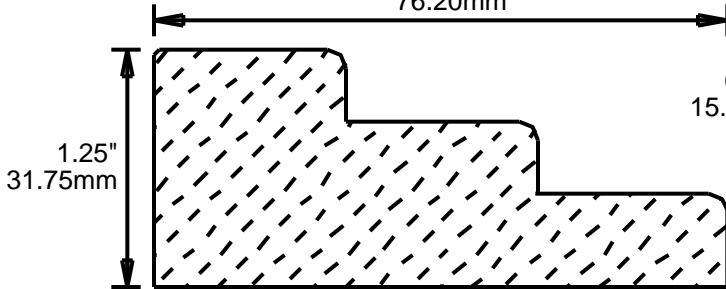

**CB3006802**

3"  
76.20mm

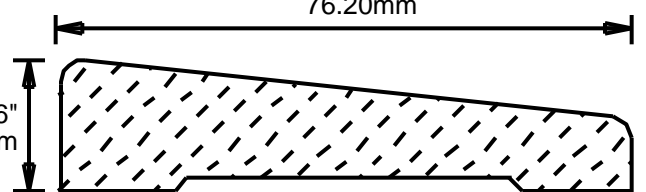

**CB3006801**

3"  
76.20mm

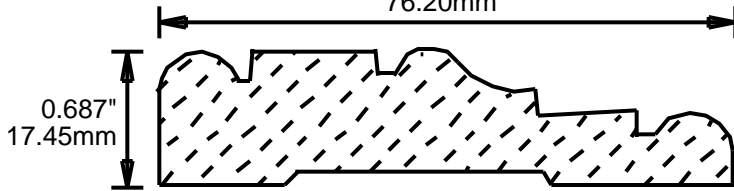

**CB3006803**

3"  
76.20mm

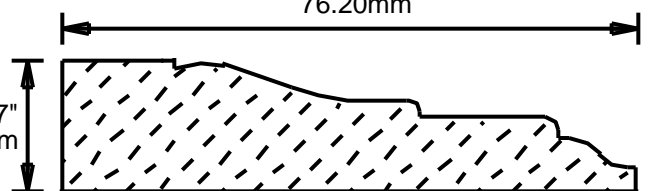

**CB3006804**

3"  
76.20mm

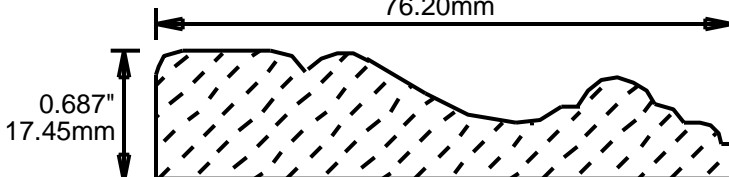

# WEINIG CASING AND BASE PATTERNS

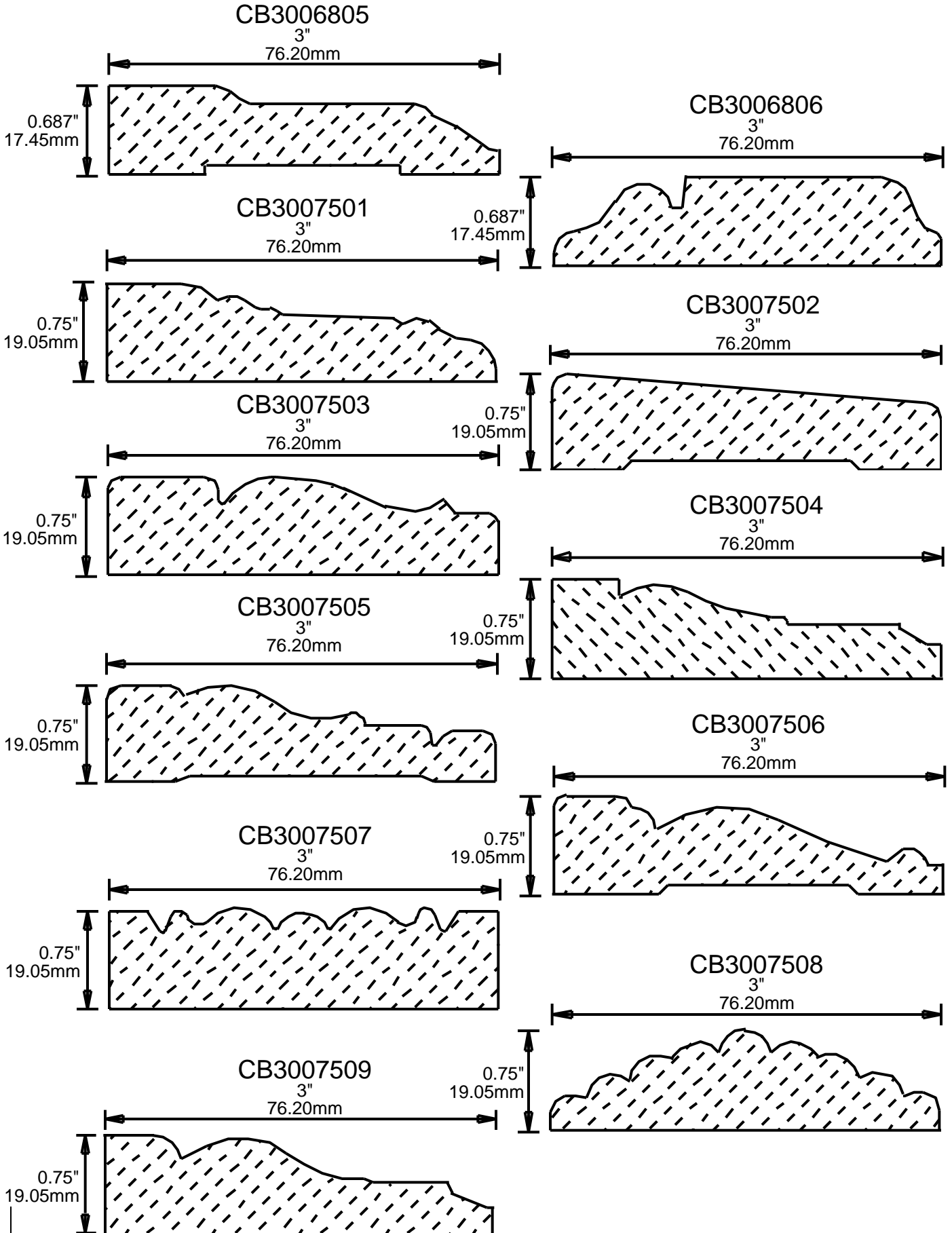

# WEINIG CASING AND BASE PATTERNS

CB3008101

3"

76.20mm

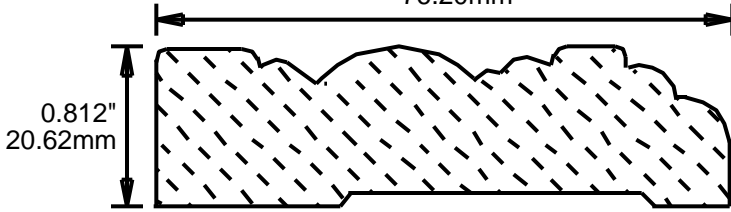

CB3008103

3"

76.20mm

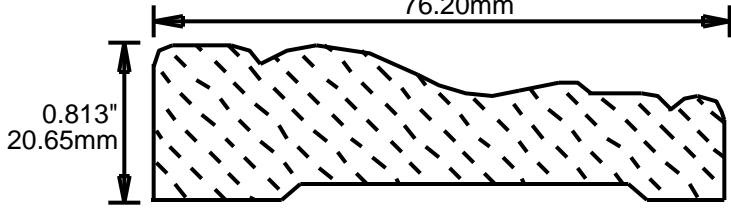

CB3008104

3"

76.20mm

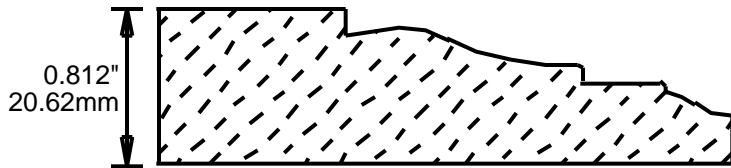

CB3008701

3"

76.20mm

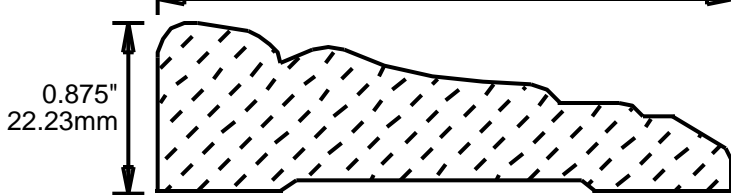

CB3008702

3"

76.20mm

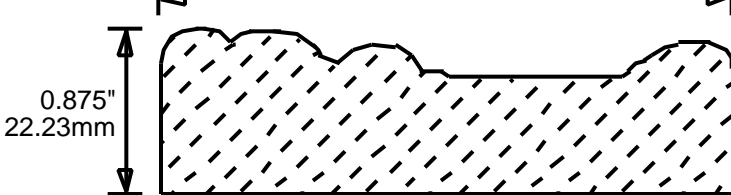

CB3127501

3.125"

79.38mm

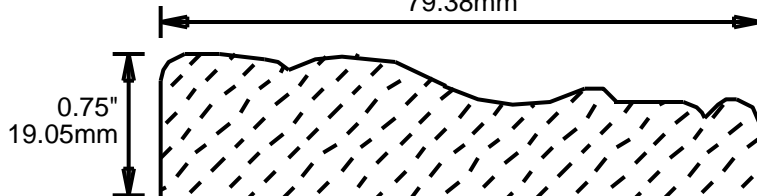

CB3127502

3.125"

79.38mm

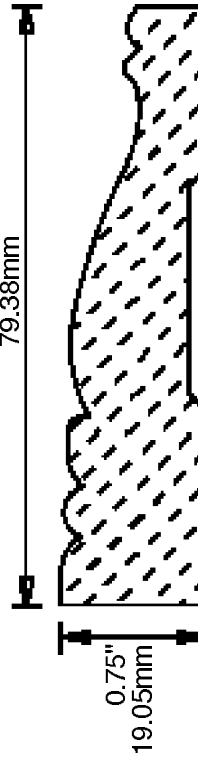

CB3128701

3.125"

79.38mm

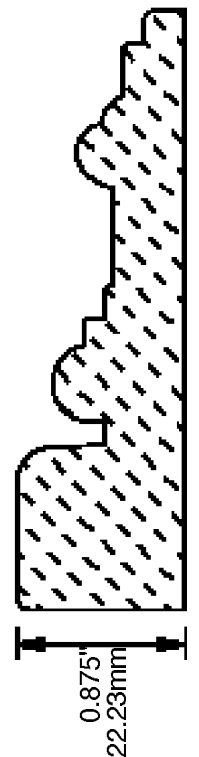

CB3187501

3.187"

80.95mm

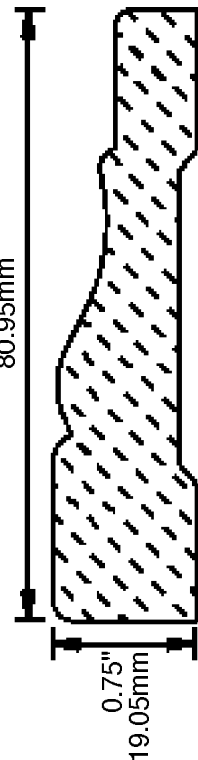

CB3251000

3.25"

82.55mm

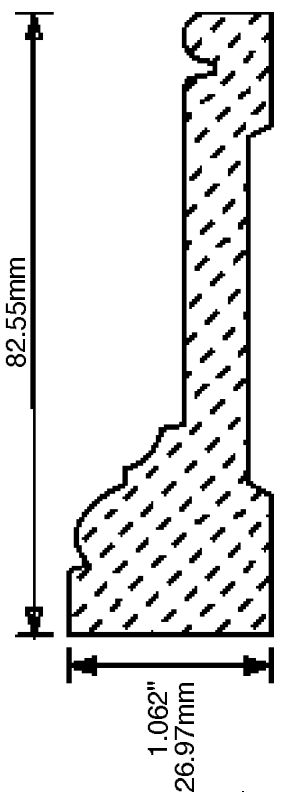

# WEINIG CASING AND BASE PATTERNS

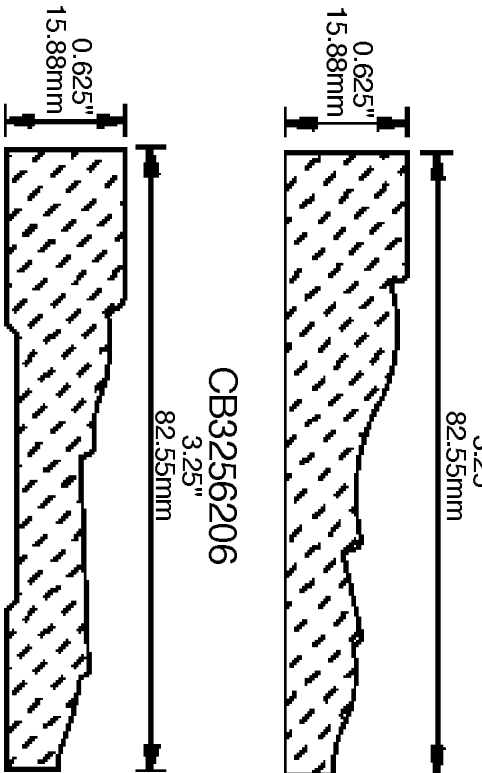
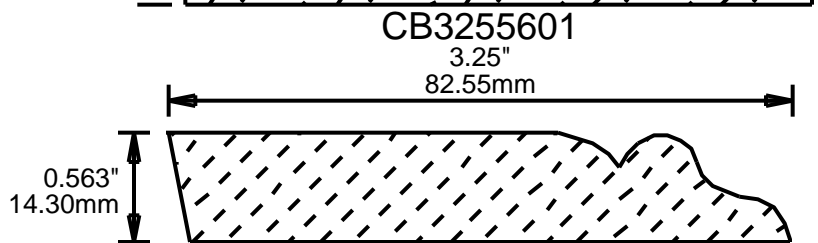
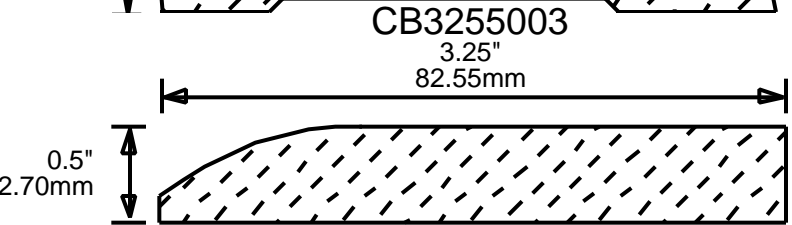
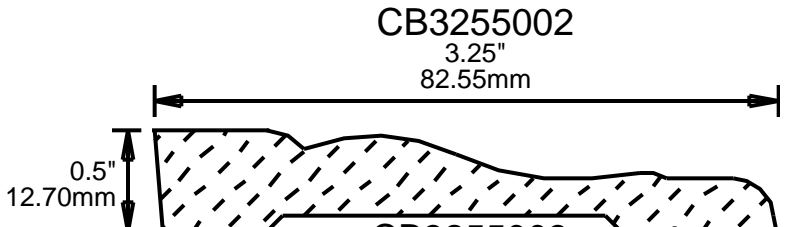
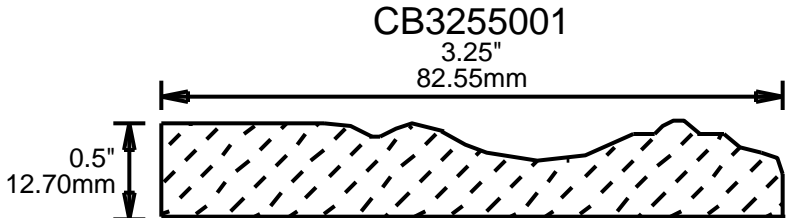
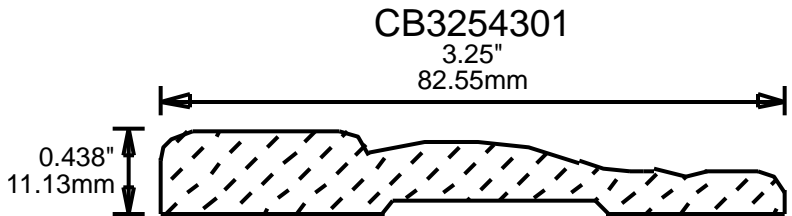
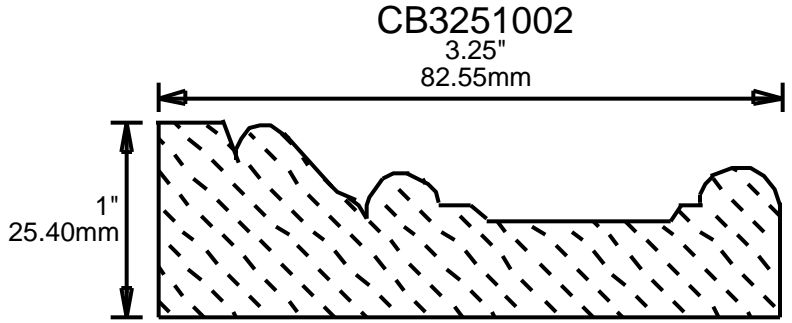
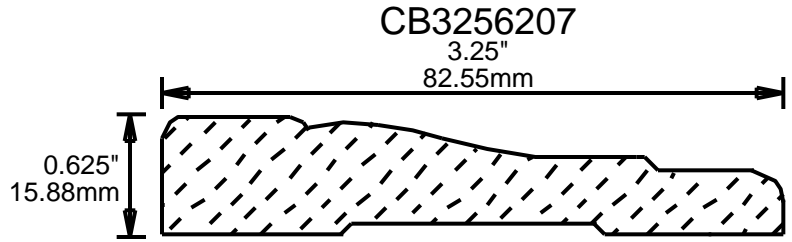
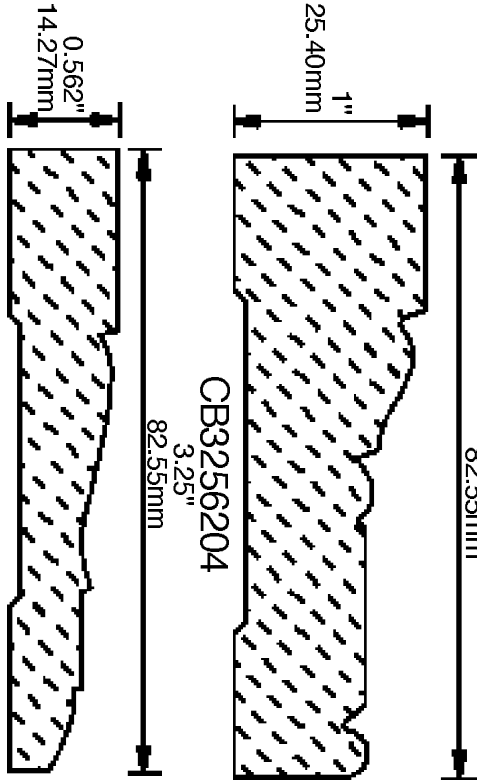



# WEINIG CASING AND BASE PATTERNS

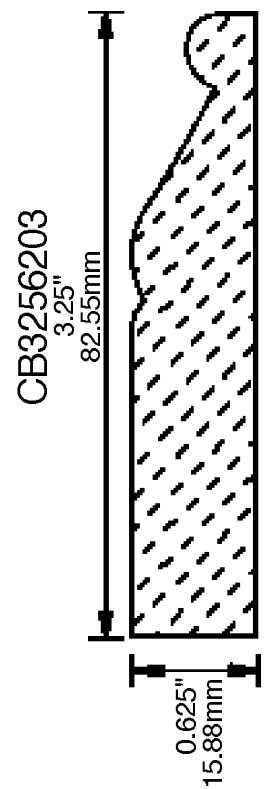
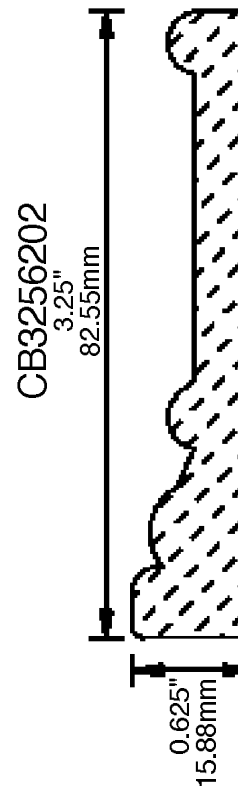
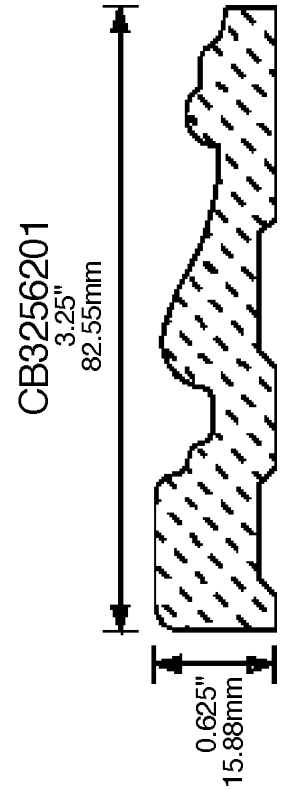
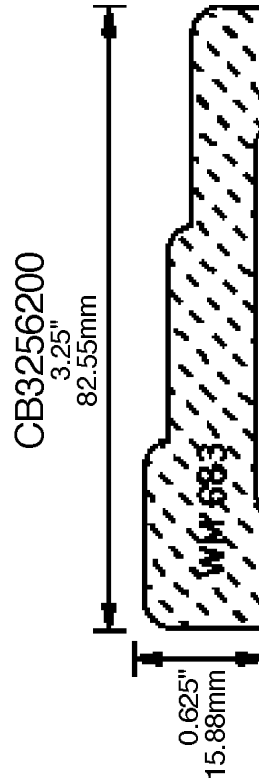
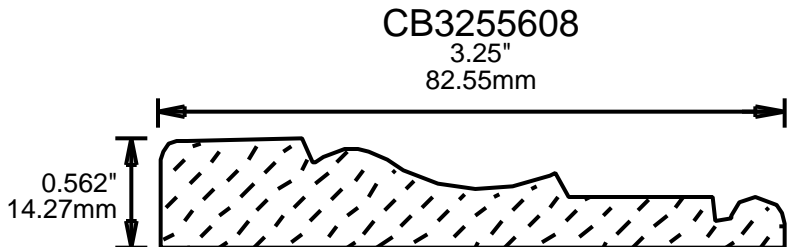
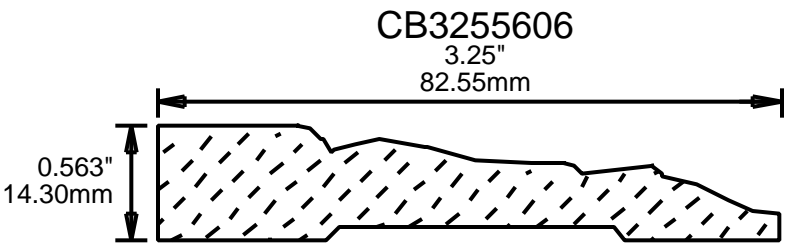
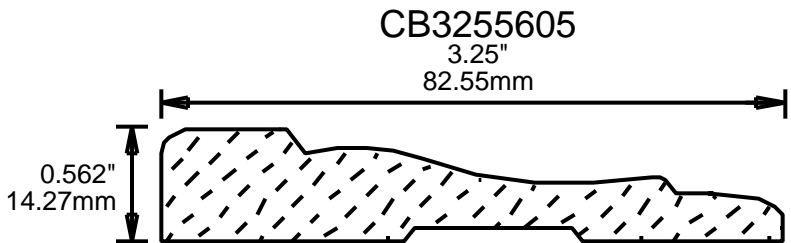
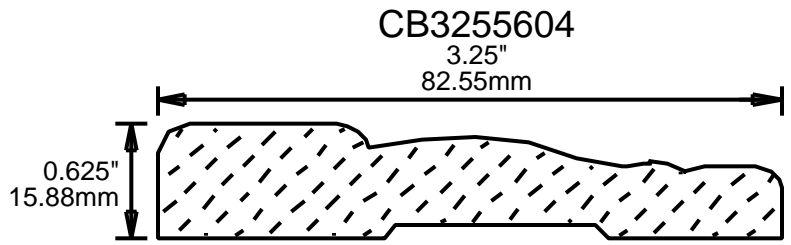
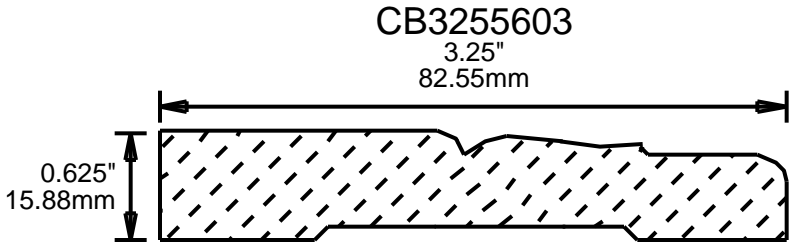
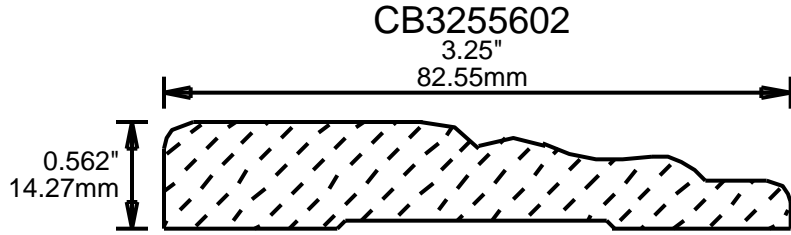

# WEINIG CASING AND BASE PATTERNS

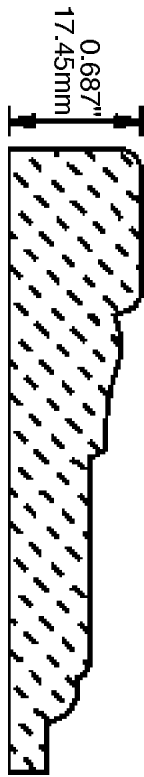

CB3256810  
3.25"  
82.55mm

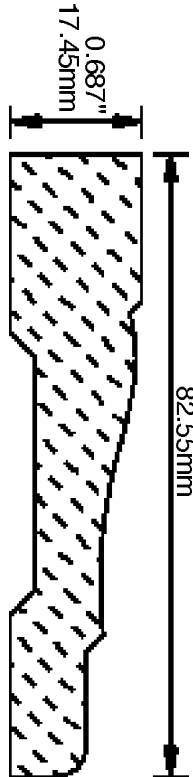

CB3256809  
3.25"  
82.55mm

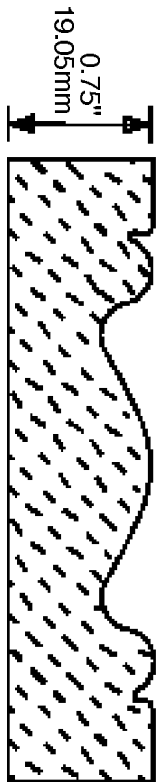

CB3257500  
3.25"  
82.55mm

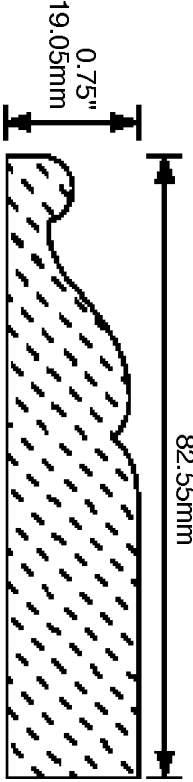

CB3256811  
3.25"  
82.55mm

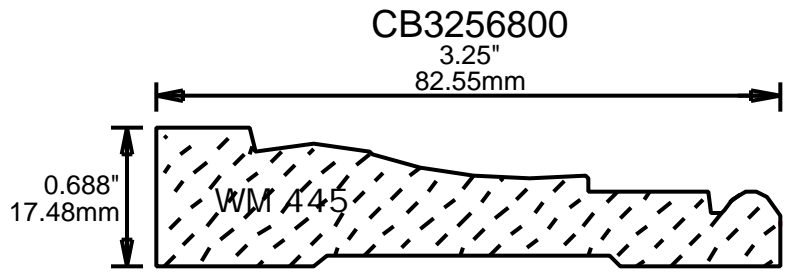

CB3256800  
3.25"  
82.55mm

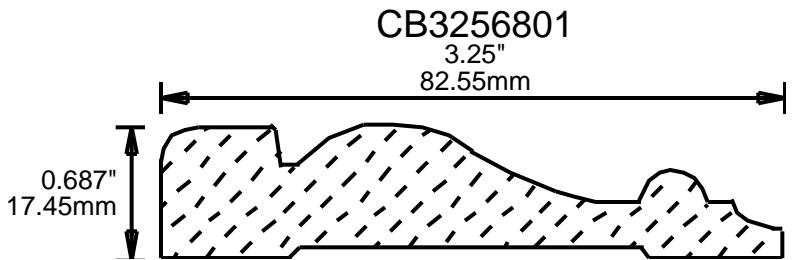

CB3256801  
3.25"  
82.55mm

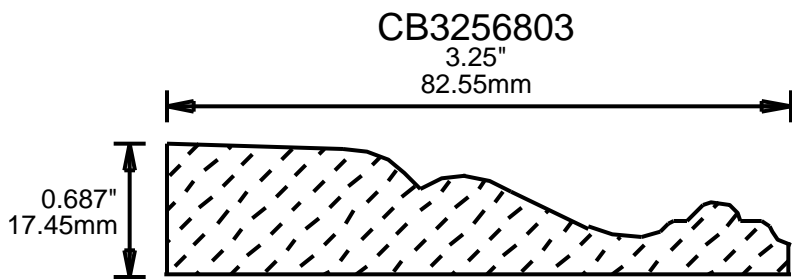

CB3256803  
3.25"  
82.55mm

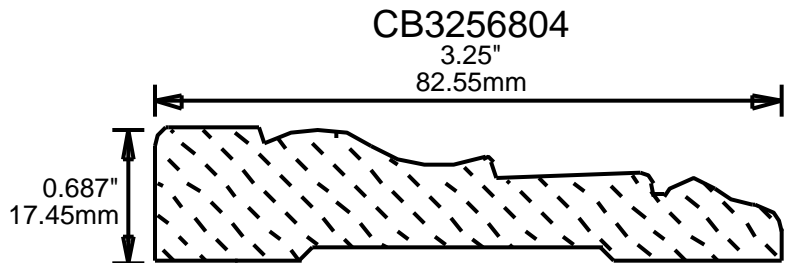

CB3256804  
3.25"  
82.55mm

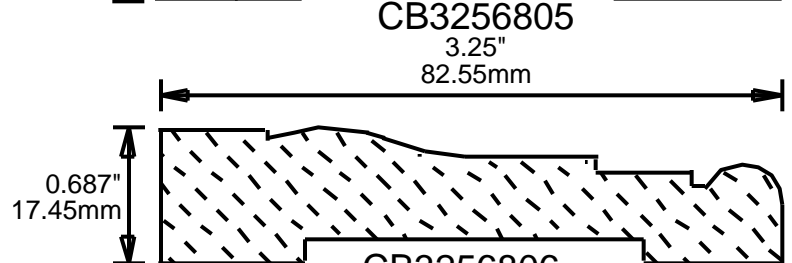

CB3256805  
3.25"  
82.55mm

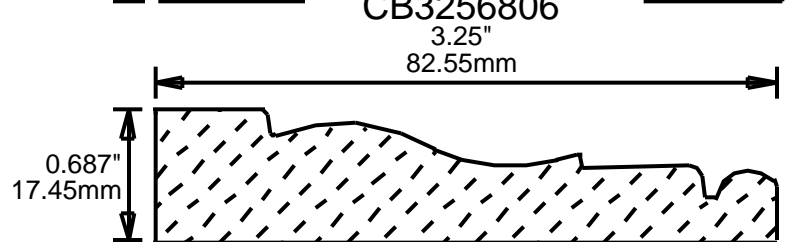

CB3256806  
3.25"  
82.55mm

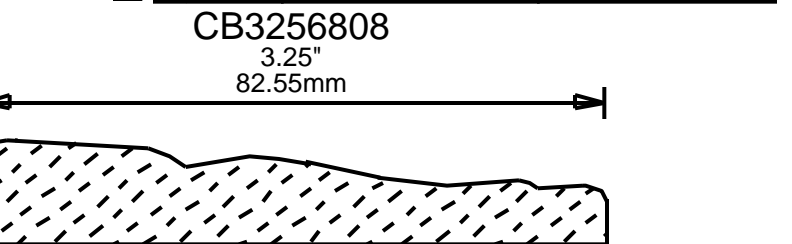

CB3256808  
3.25"  
82.55mm

0.687"  
17.45mm

# WEINIG CASING AND BASE PATTERNS

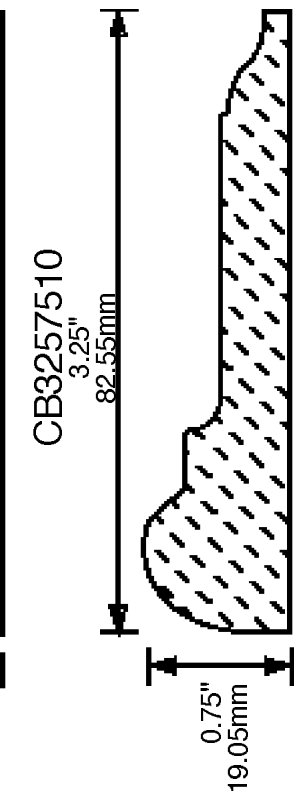
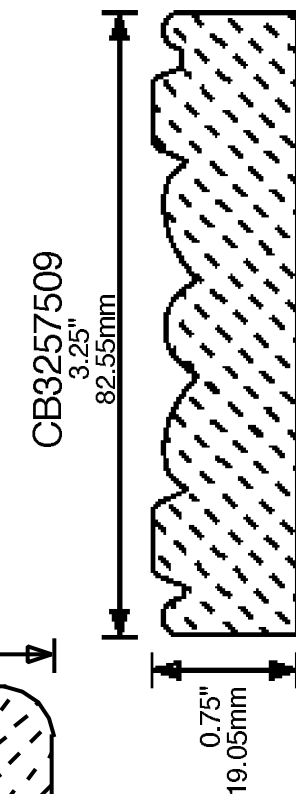
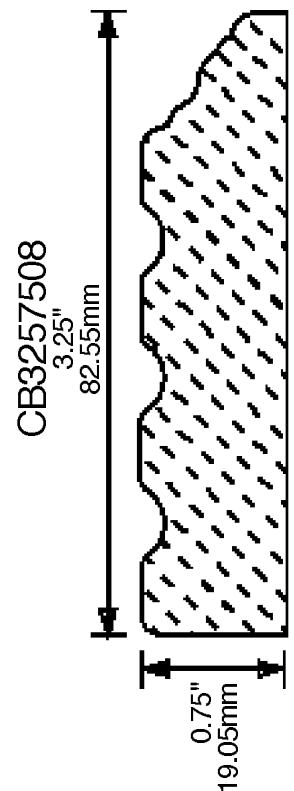
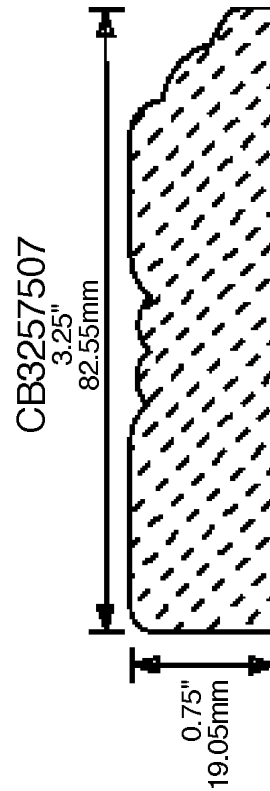
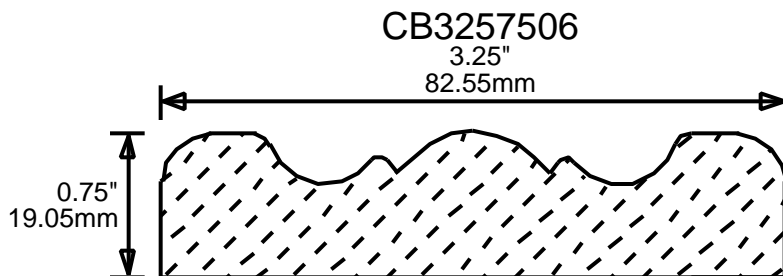
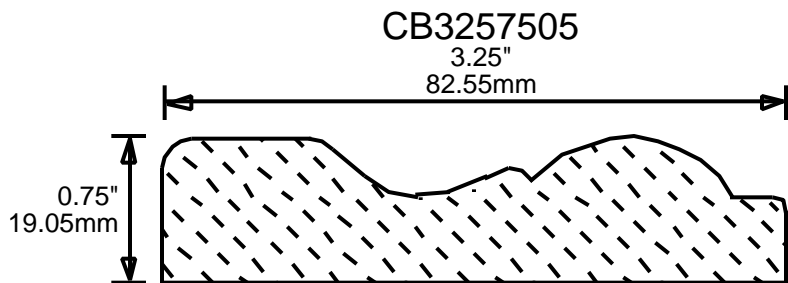
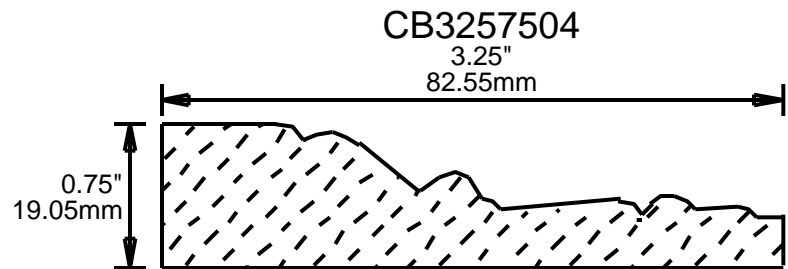
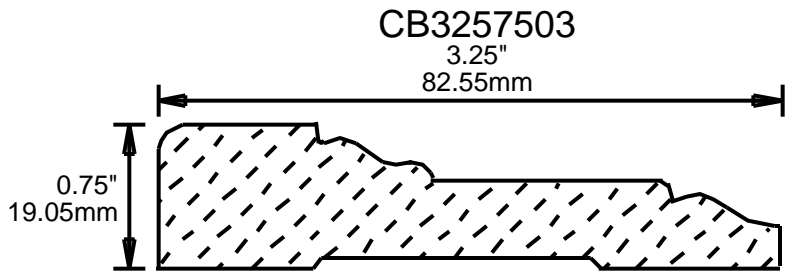
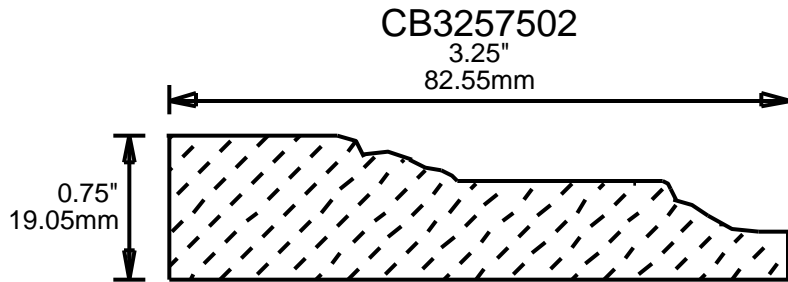
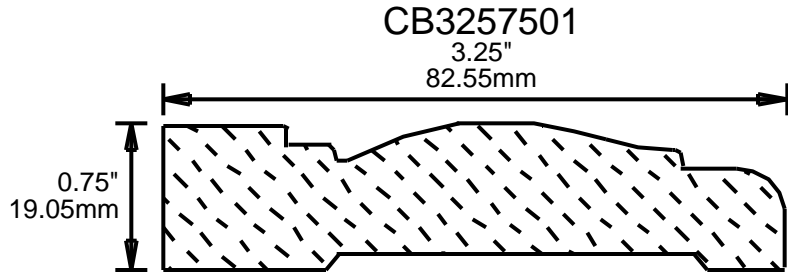

# WEINIG CASING AND BASE PATTERNS

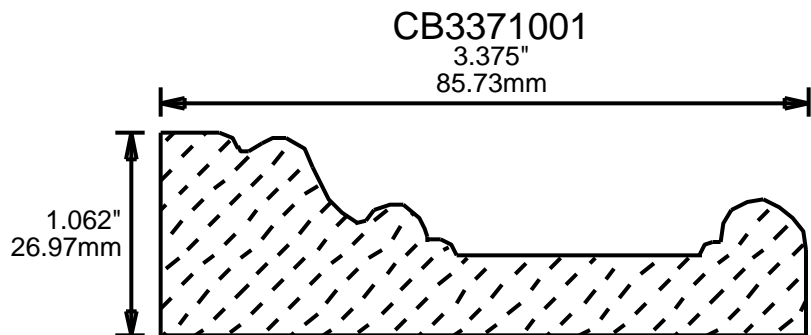
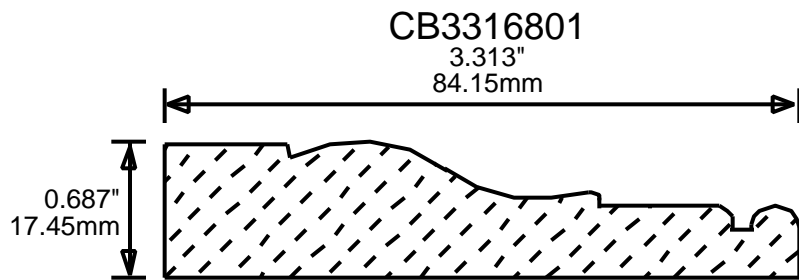
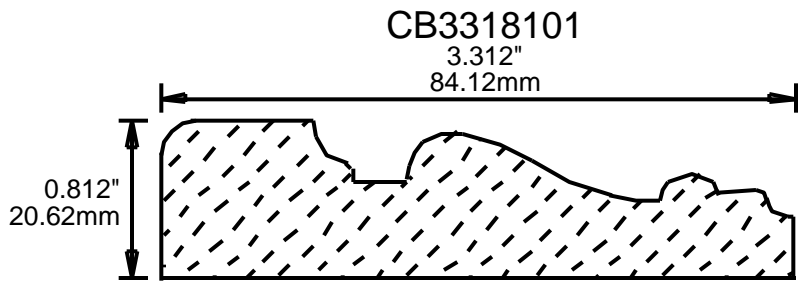
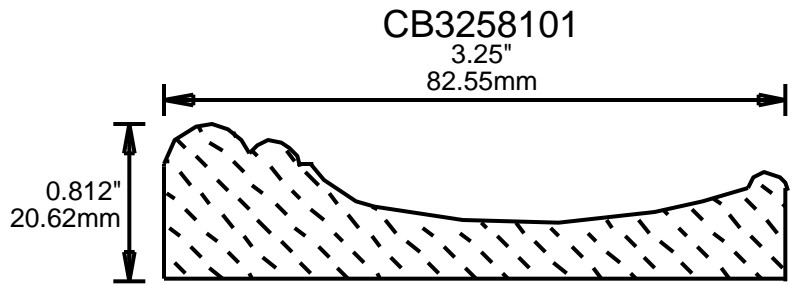
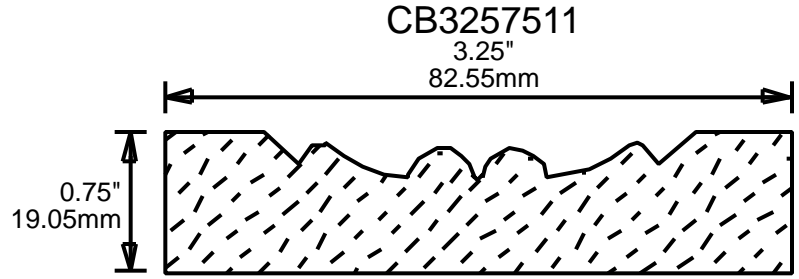
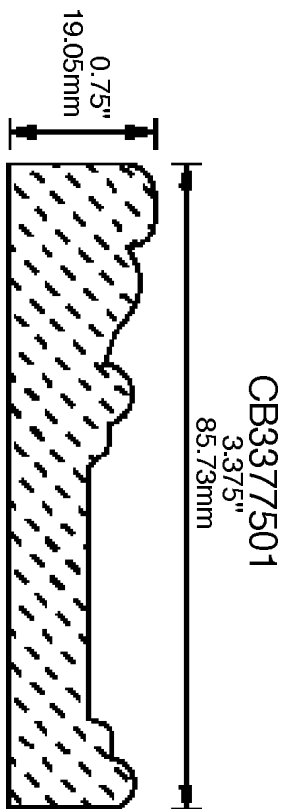
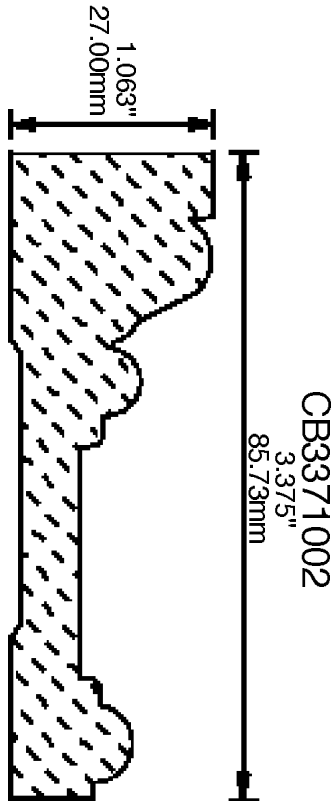

# WEINIG CASING AND BASE PATTERNS

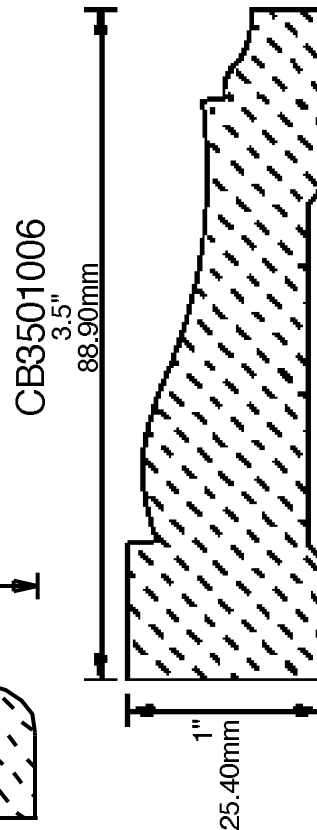
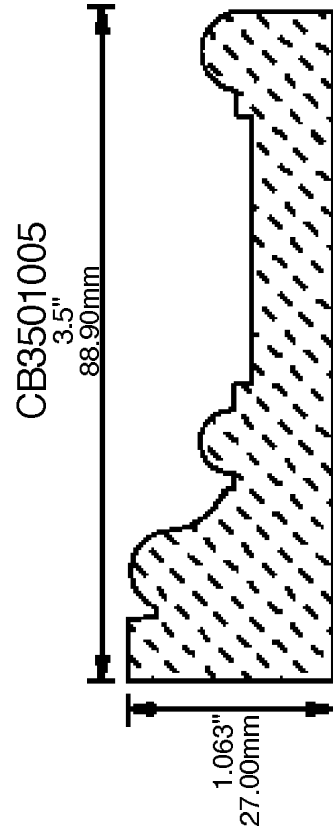
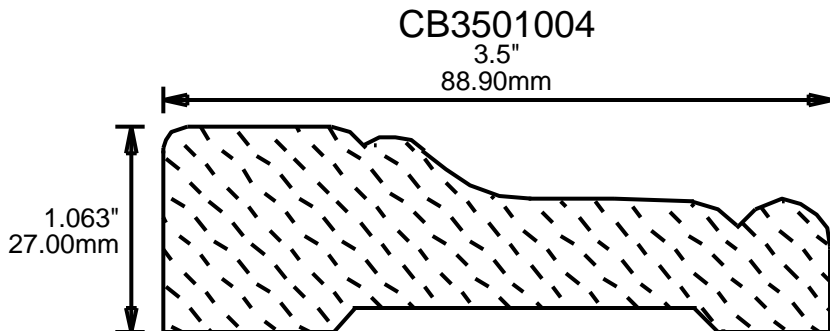
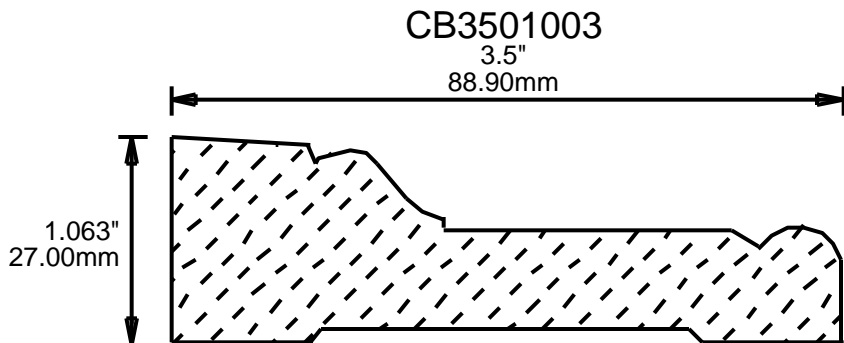
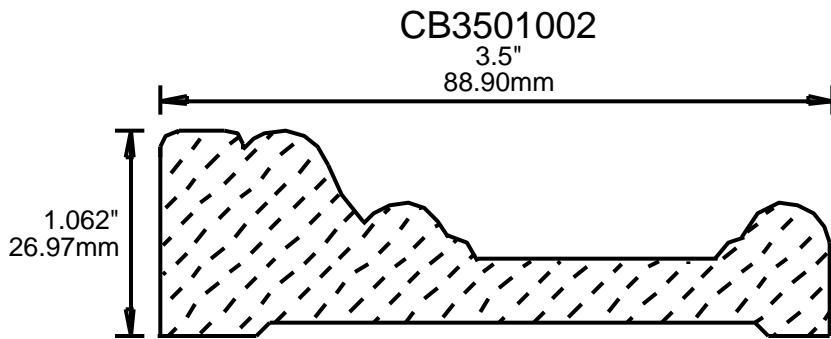
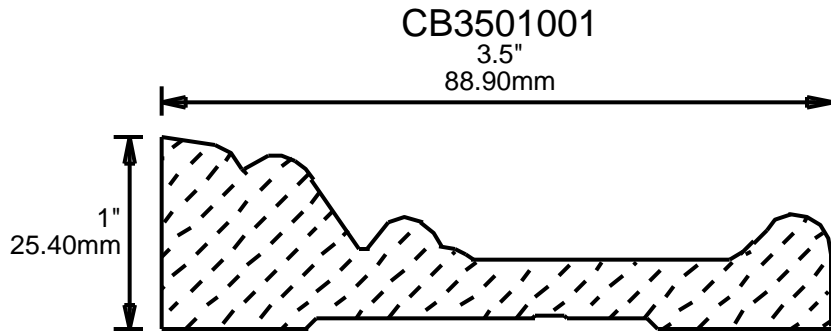
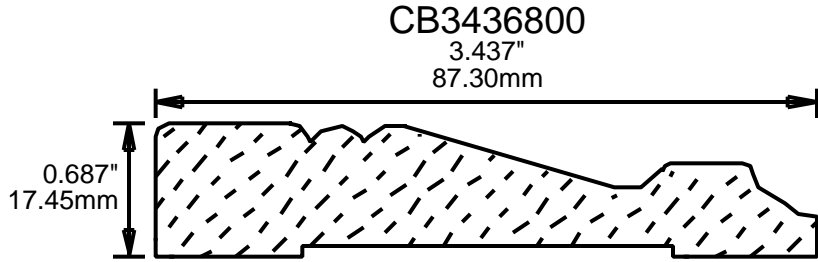

# WEINIG CASING AND BASE PATTERNS

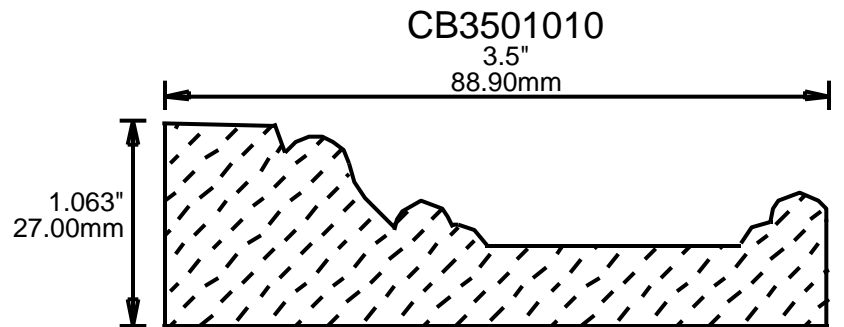
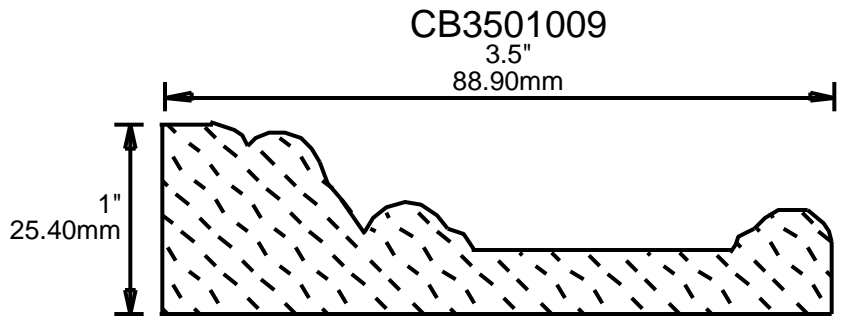
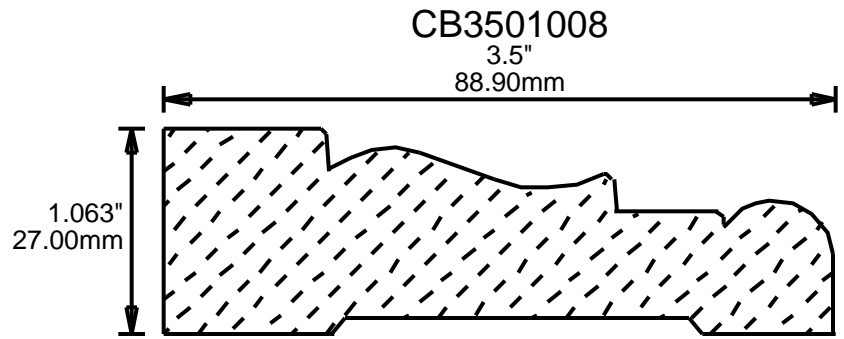
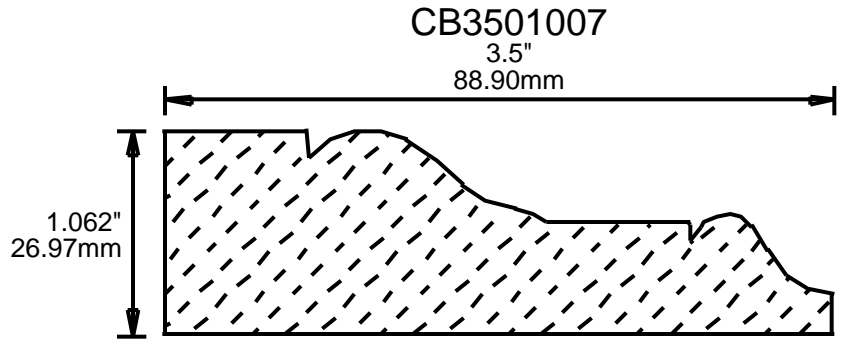
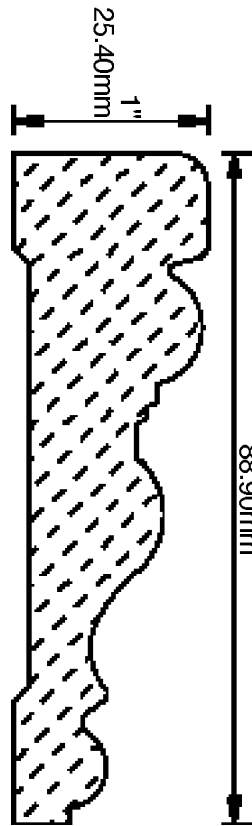

CB3501013

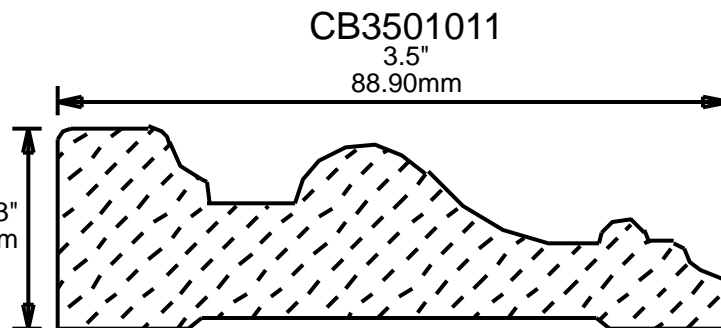
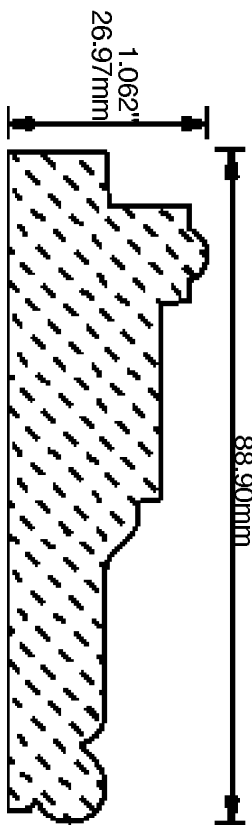

# WEINIG CASING AND BASE PATTERNS

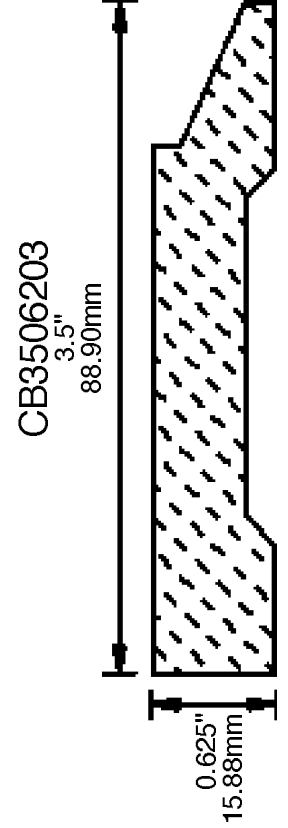
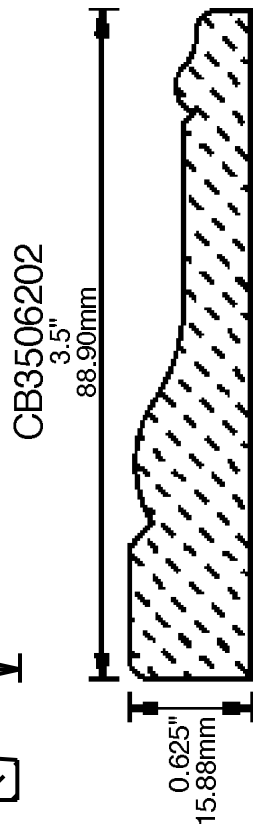
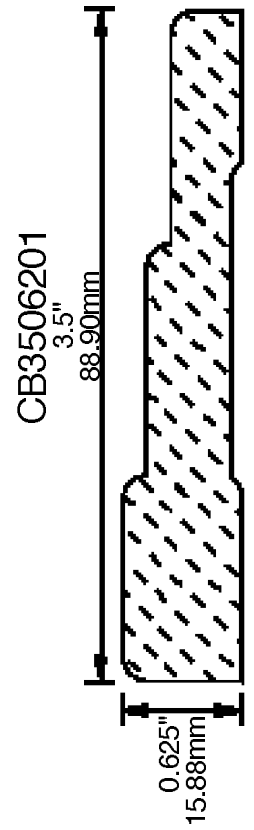
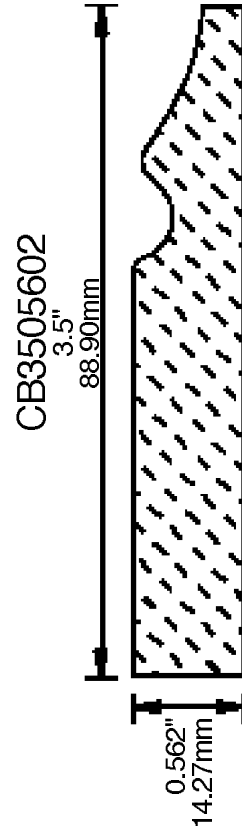
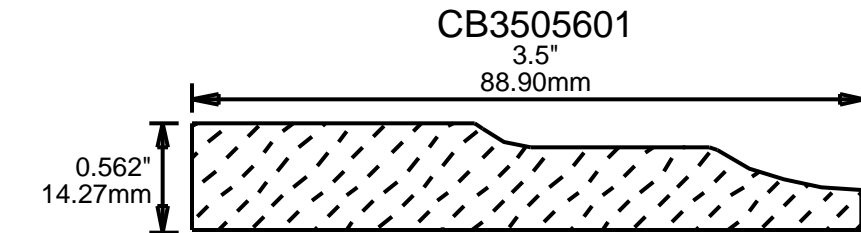
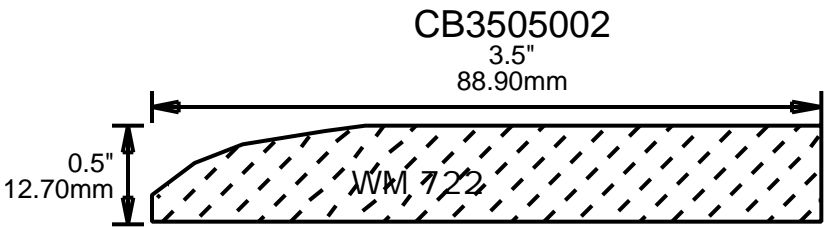
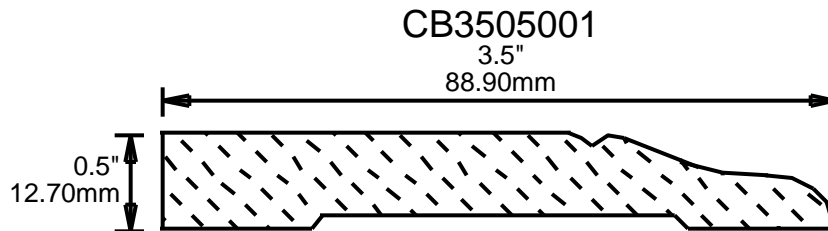
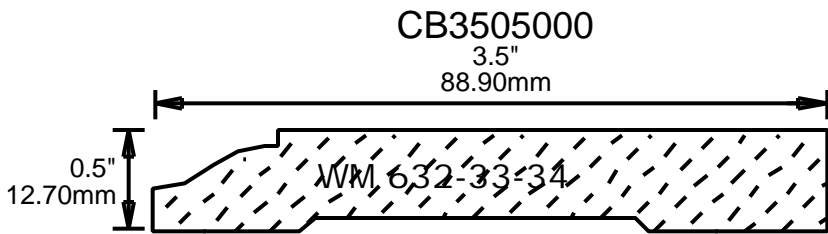
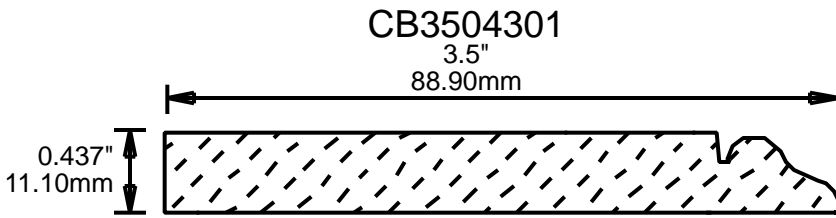
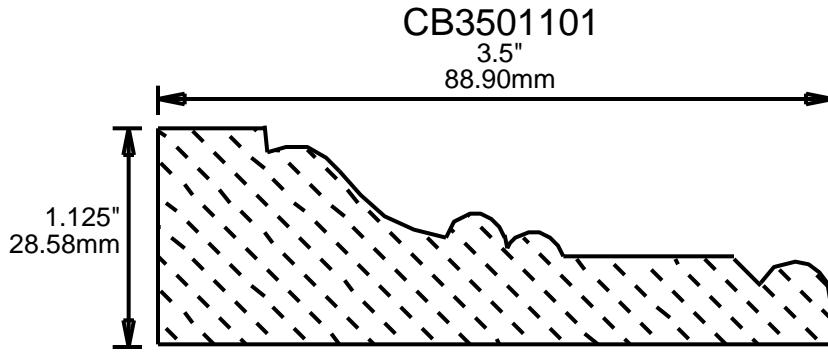

**PRINT THIS SECTION**

**RETURN TO Table of Contents**

# WEINIG CASING AND BASE PATTERNS

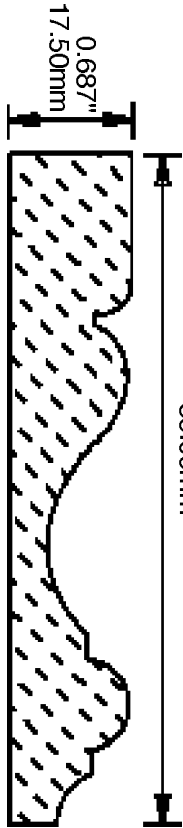

CB3506204

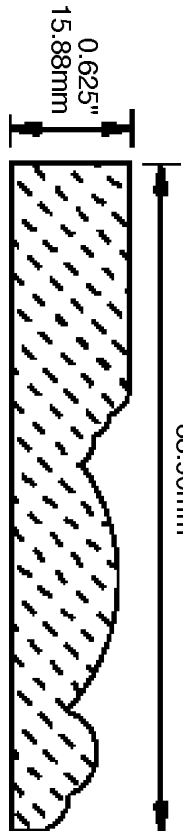

CB3506205

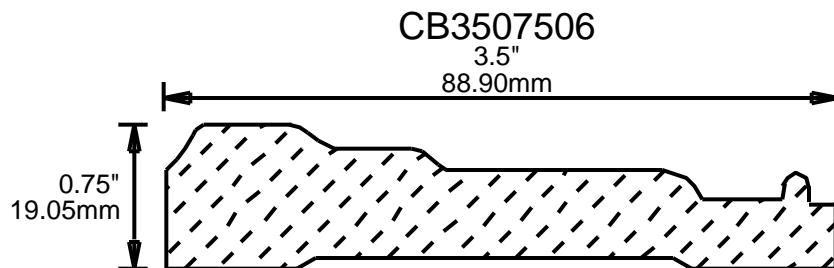
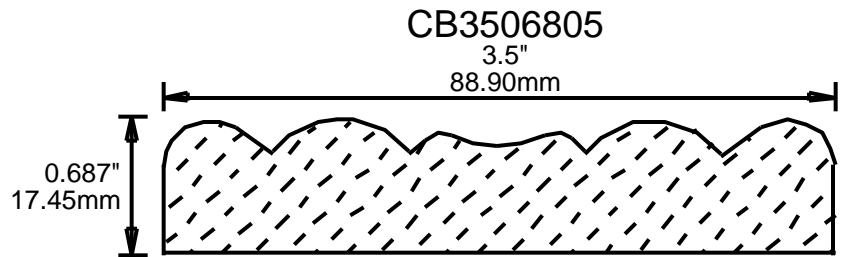
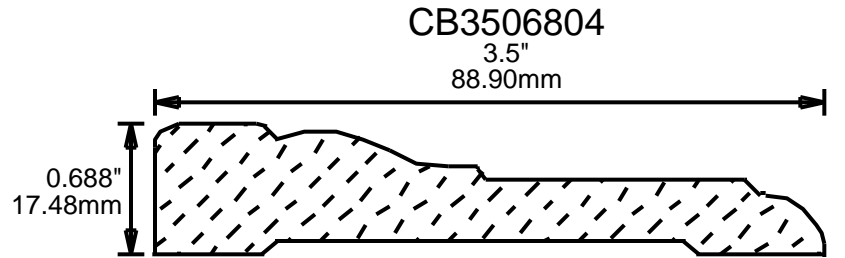
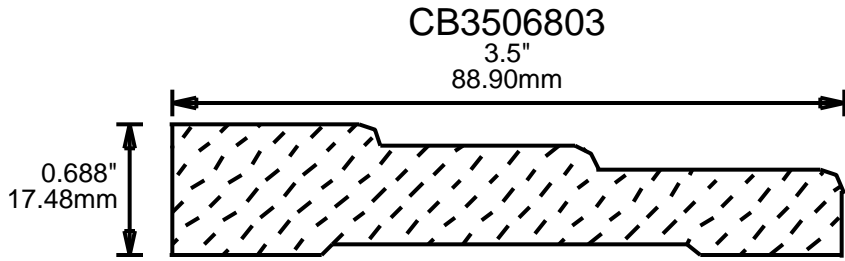
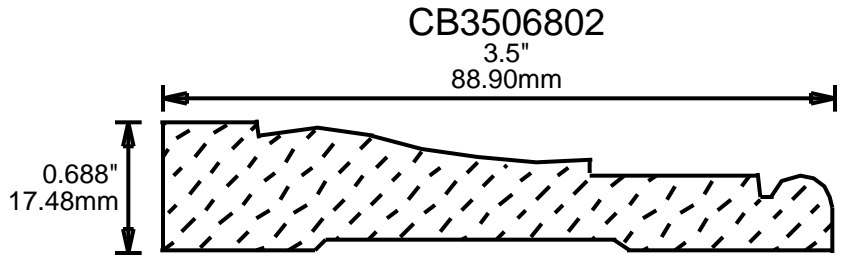
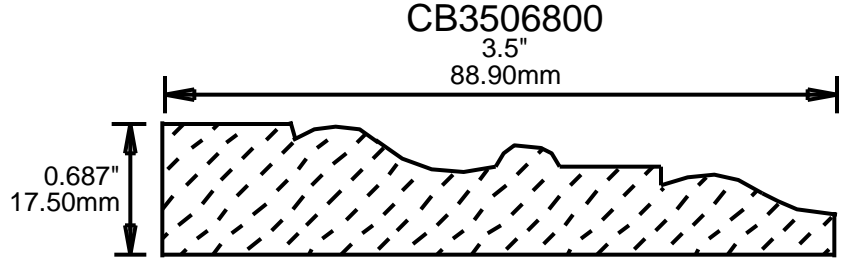



# WEINIG CASING AND BASE PATTERNS

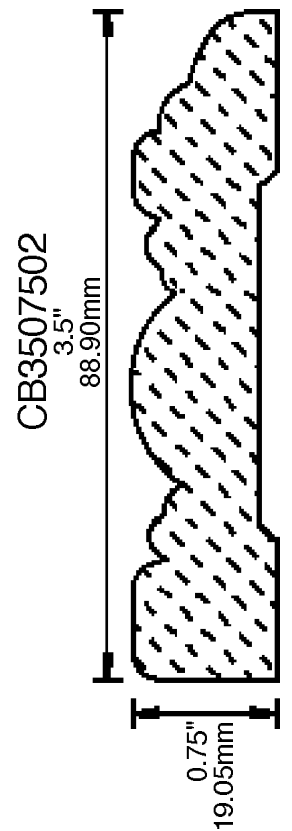
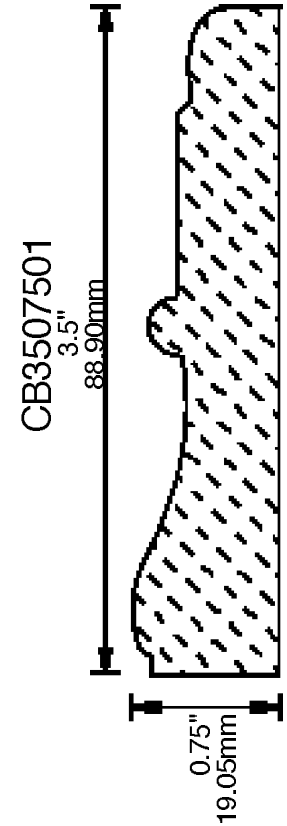
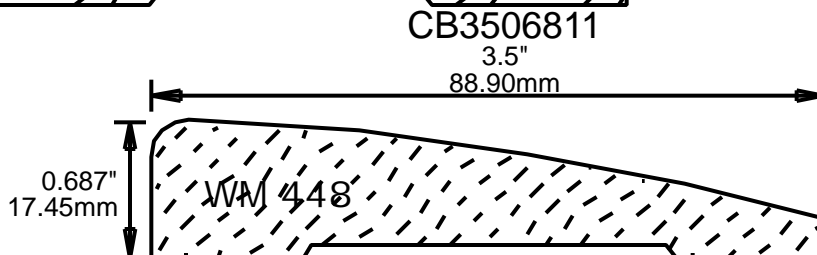
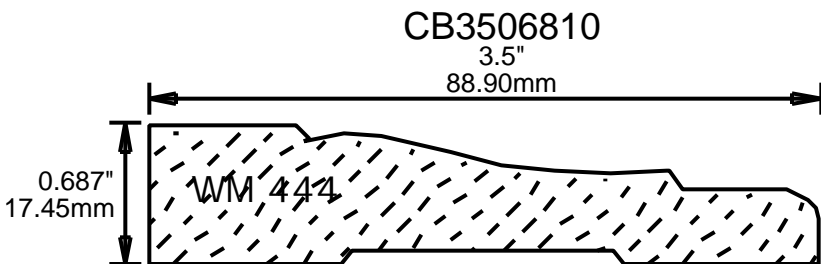
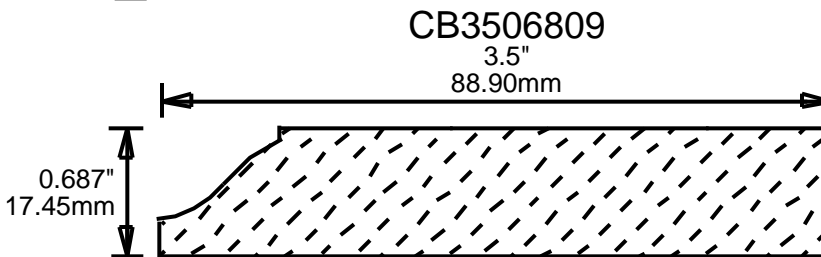
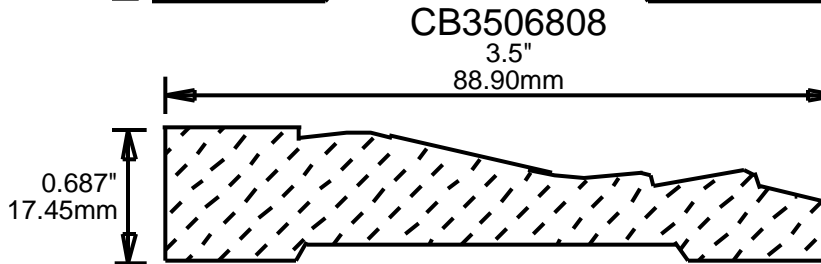
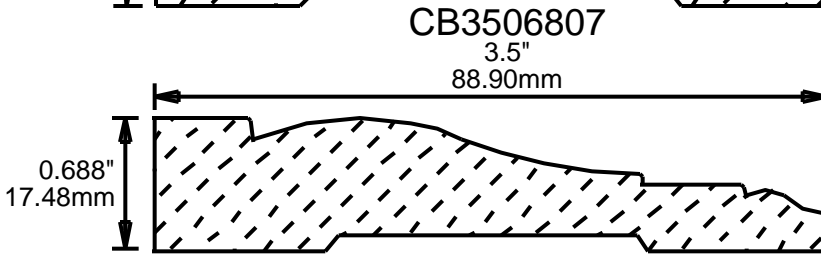
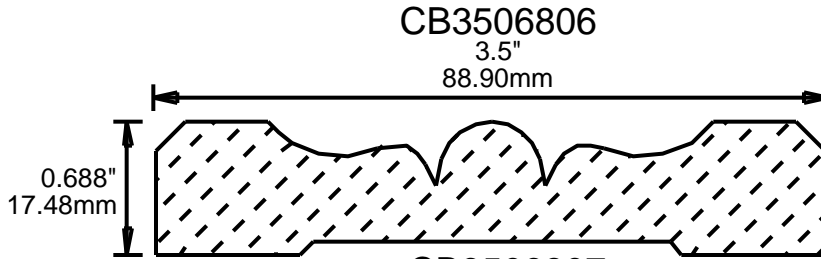
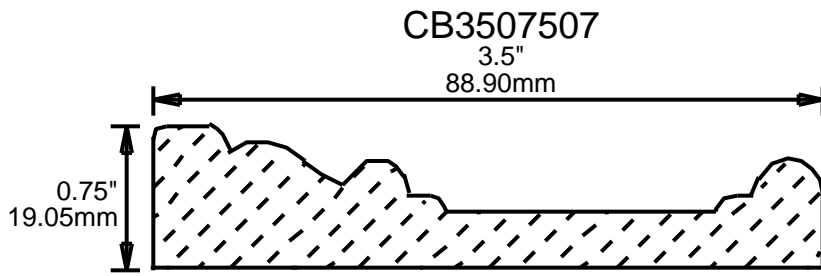

**PRINT  
THIS SECTION**

**RETURN TO  
Table of Contents**

# WEINIG CASING AND BASE PATTERNS

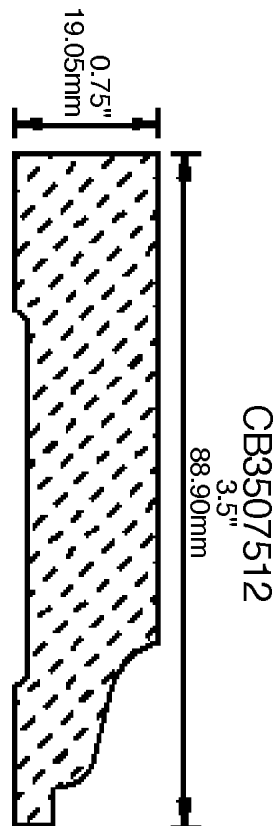
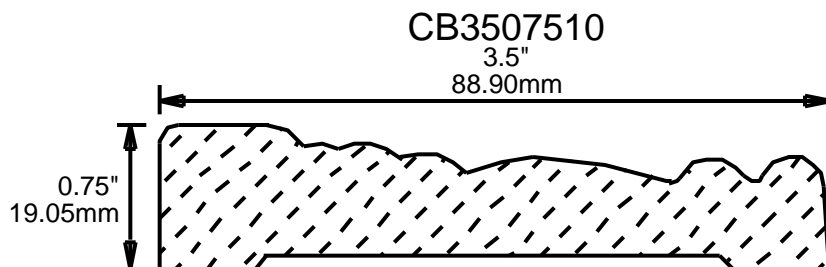
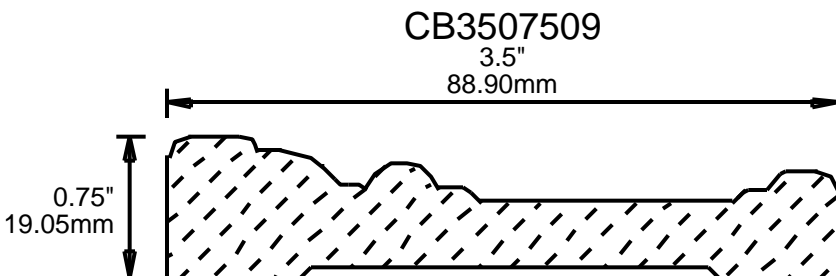
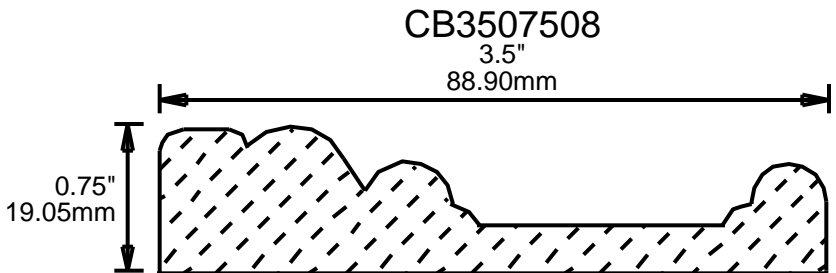
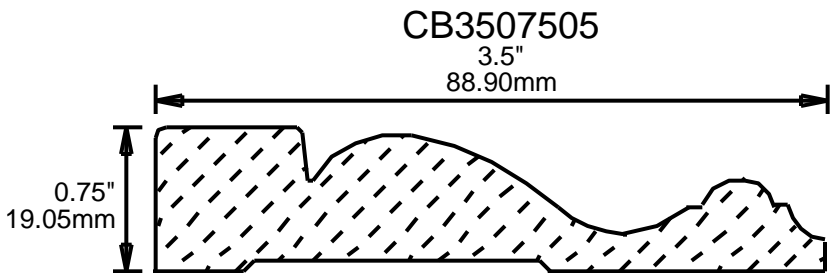
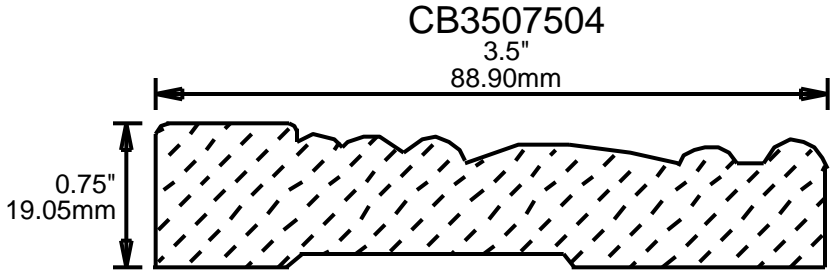
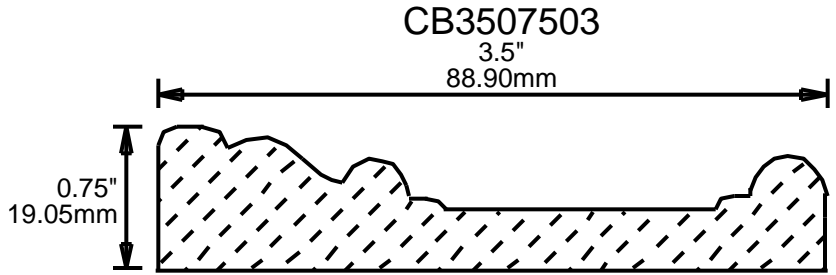
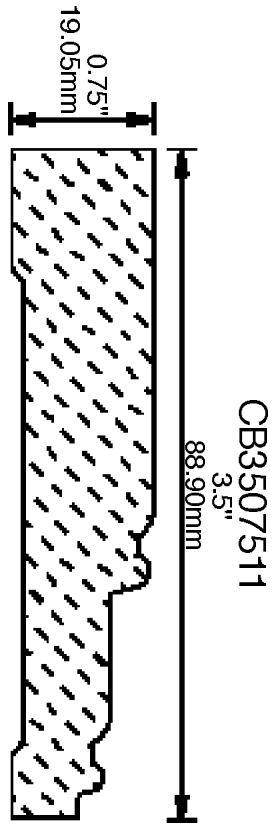

# WEINIG CASING AND BASE PATTERNS

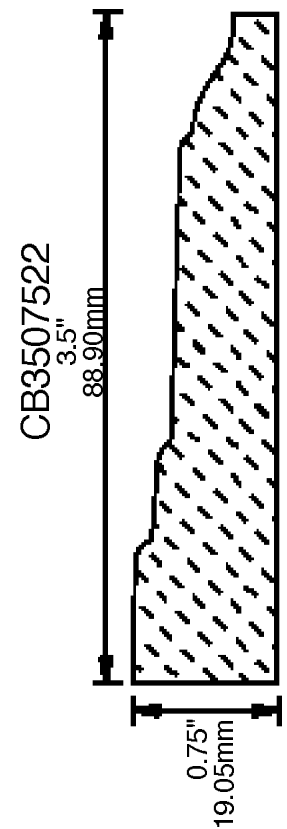
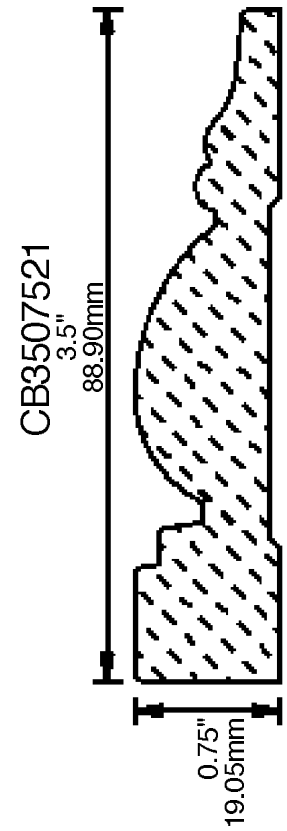
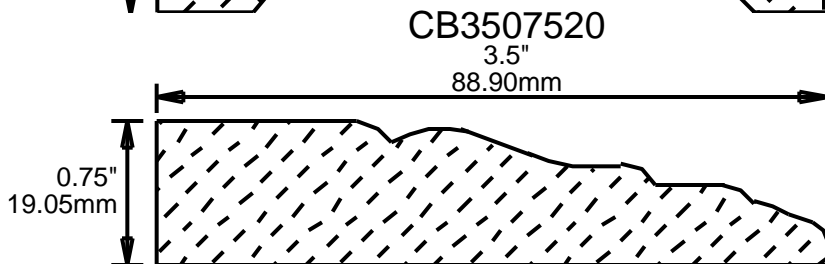
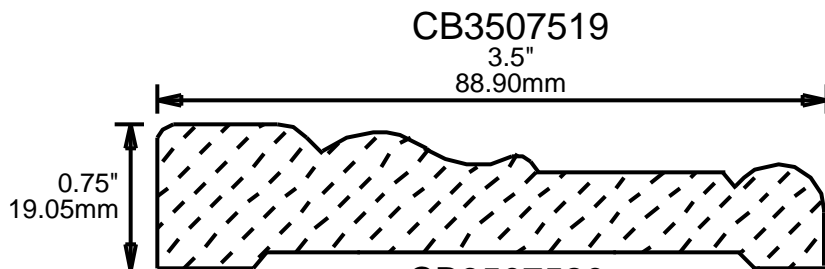
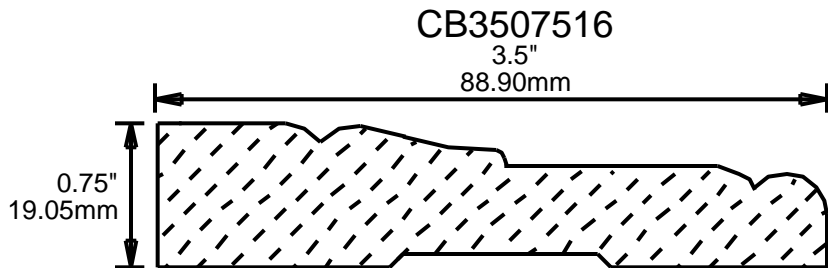
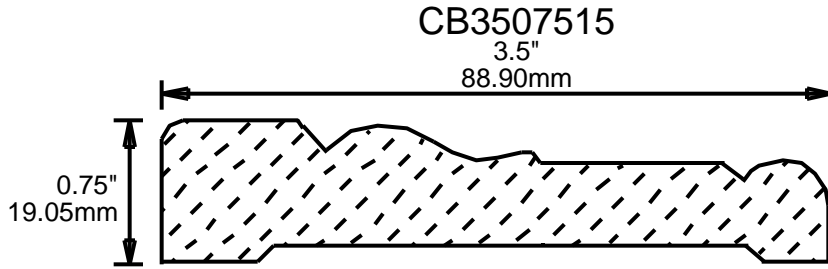
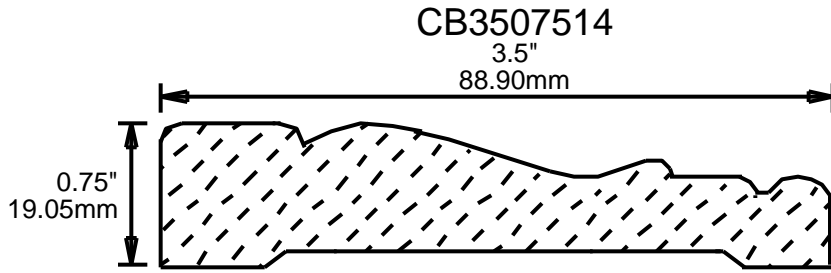
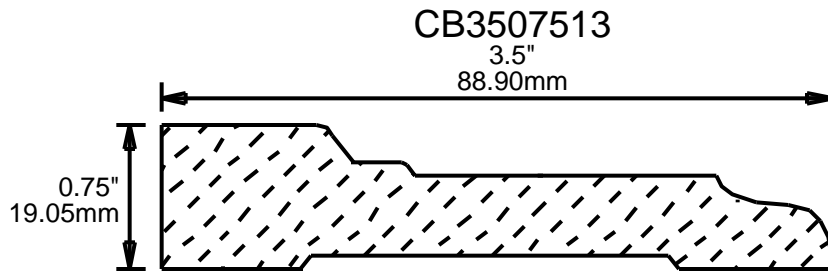

# WEINIG CASING AND BASE PATTERNS

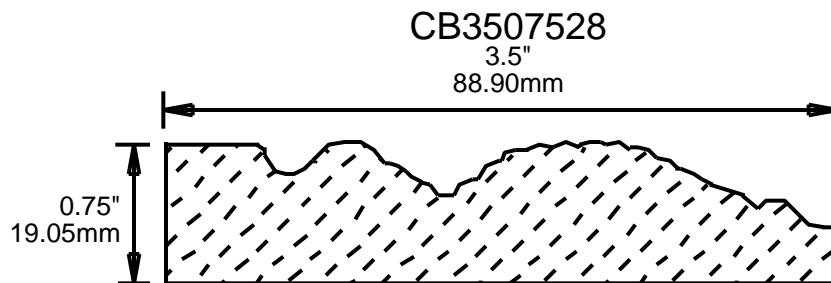
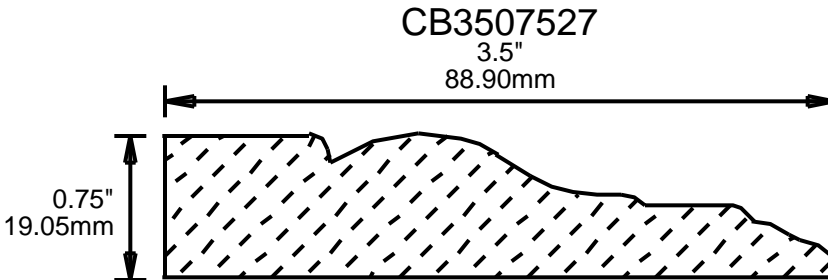
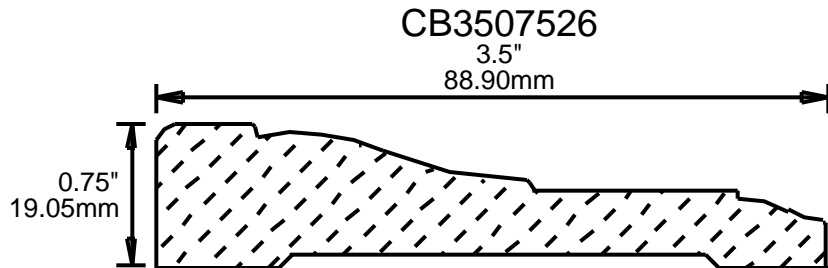
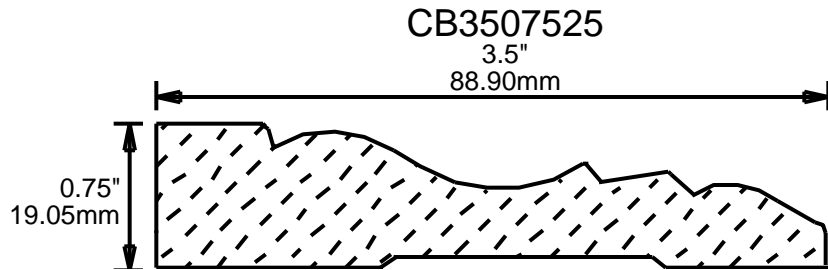
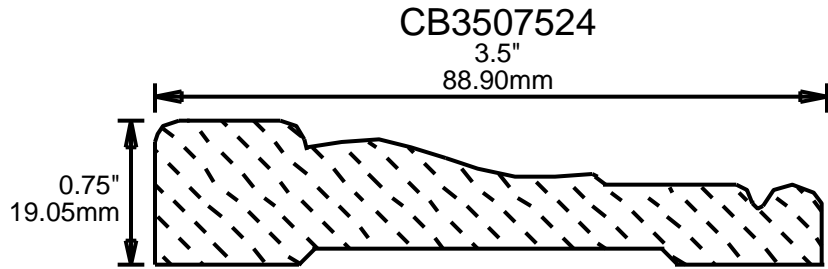
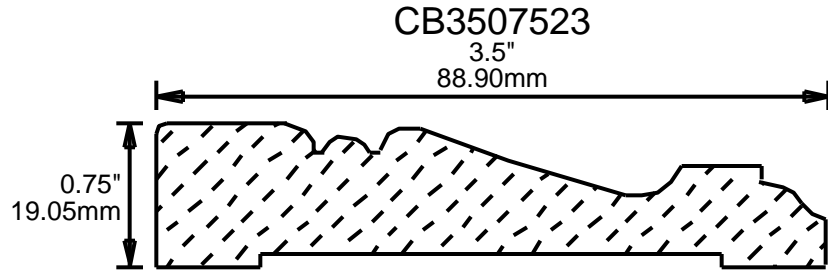
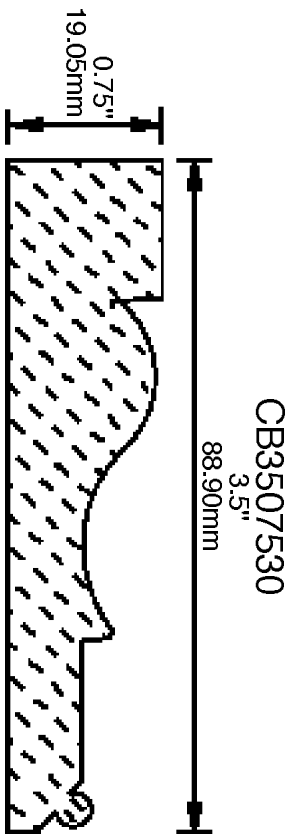
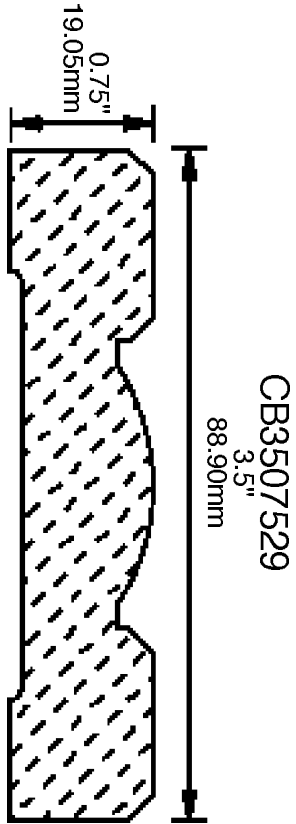

# WEINIG CASING AND BASE PATTERNS

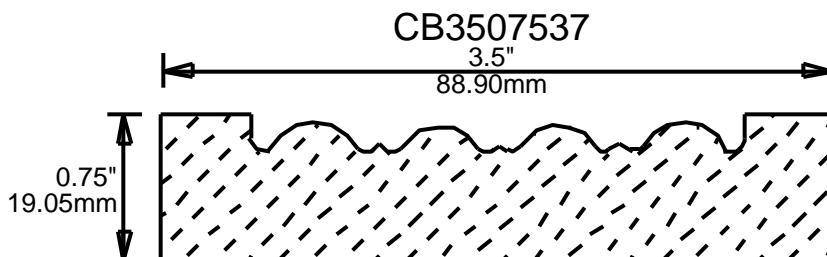
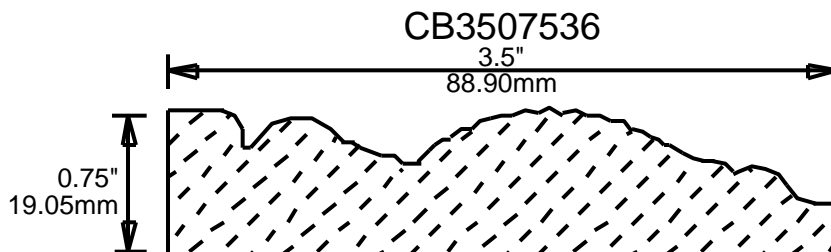
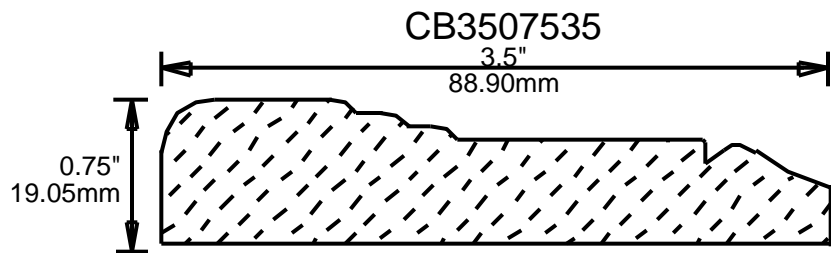
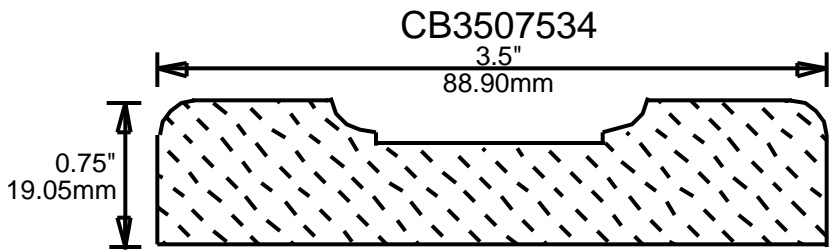
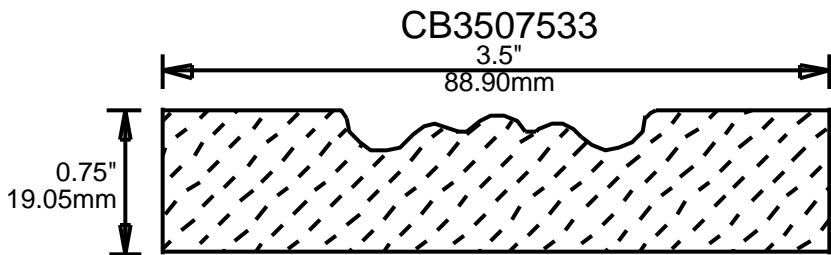
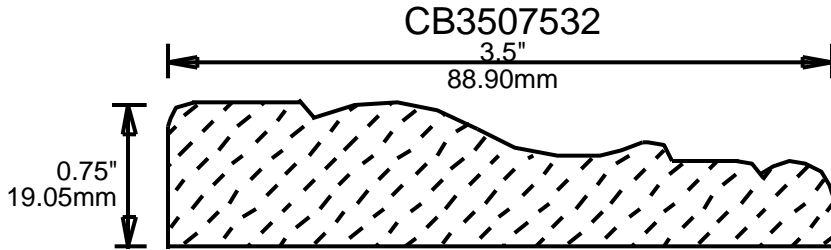
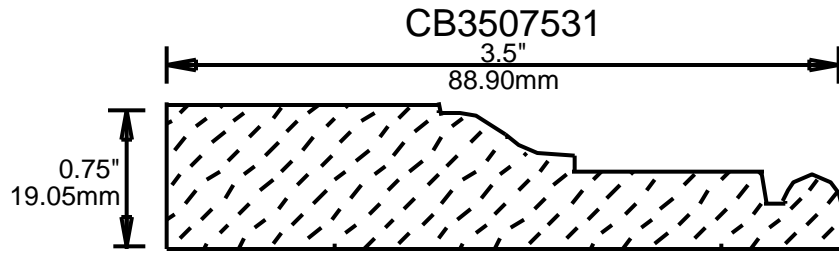

CB3507538

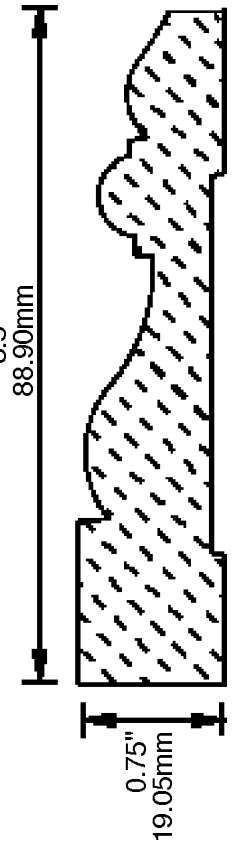

CB3508101

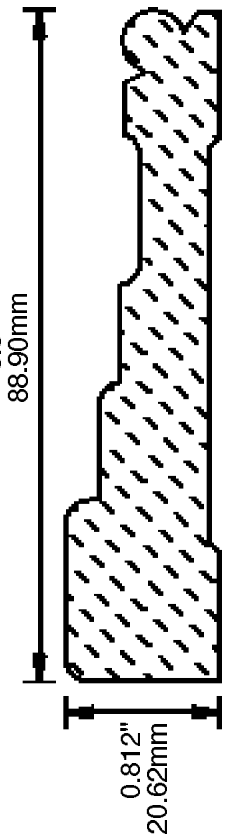

**PRINT  
THIS SECTION**

**RETURN TO  
Table of Contents**

# WEINIG CASING AND BASE PATTERNS

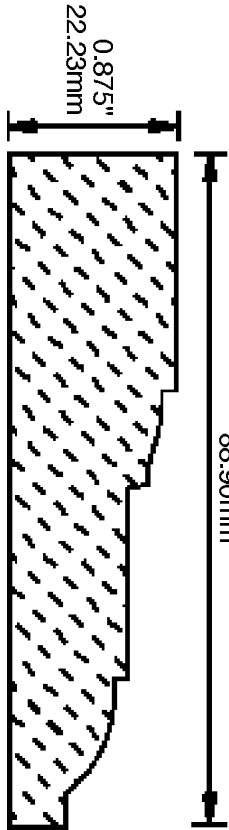

CB3508702

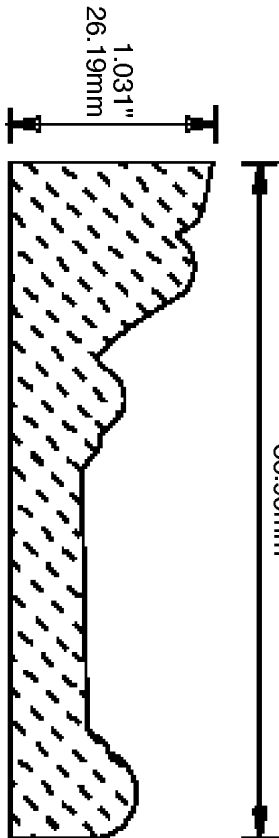
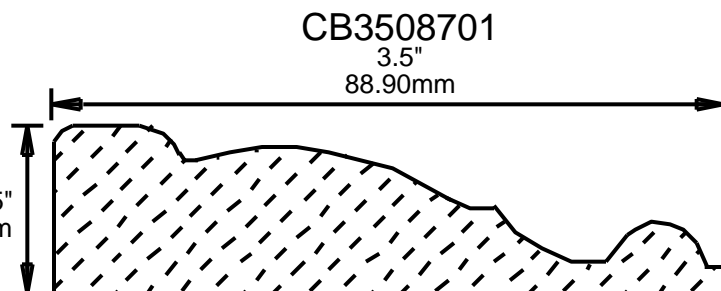
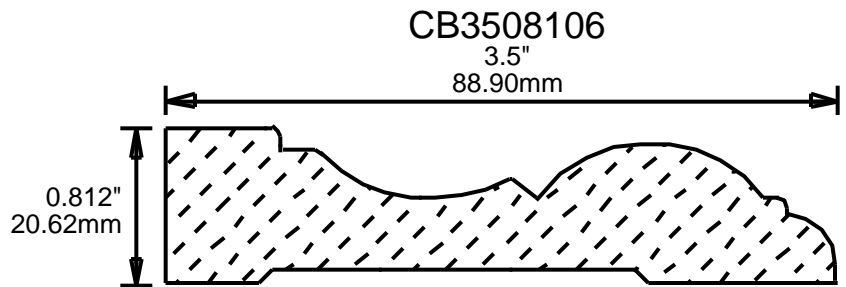
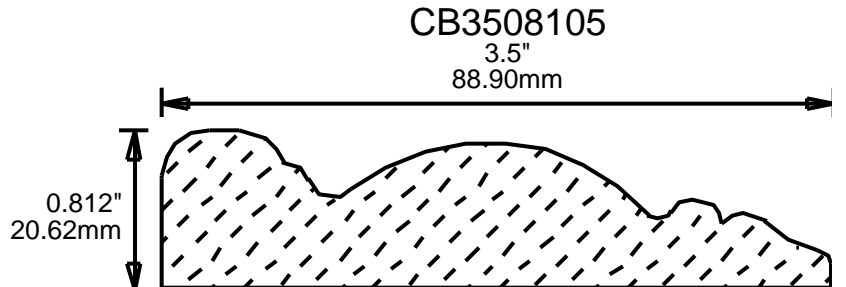
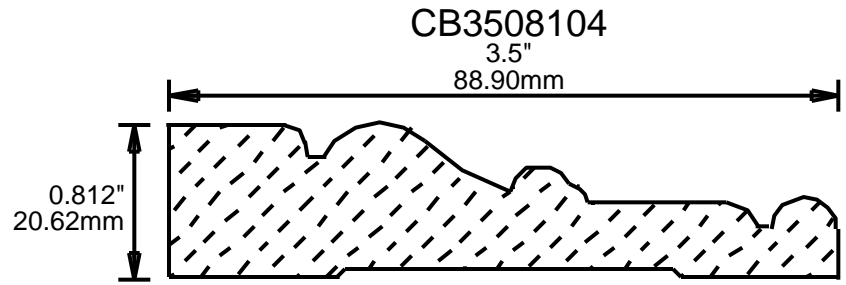
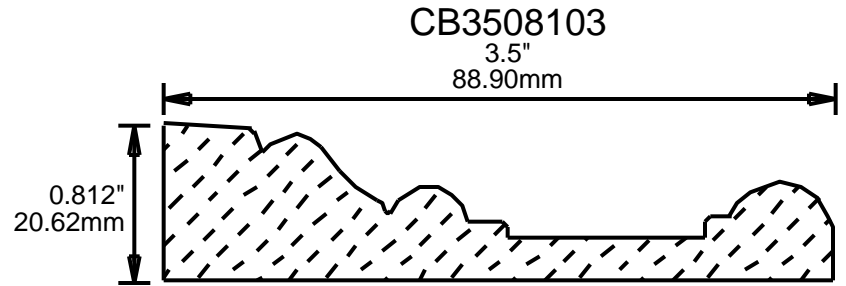
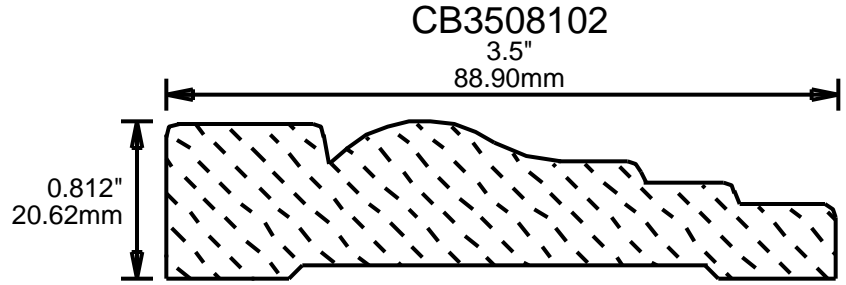

CB3561001

# WEINIG CASING AND BASE PATTERNS

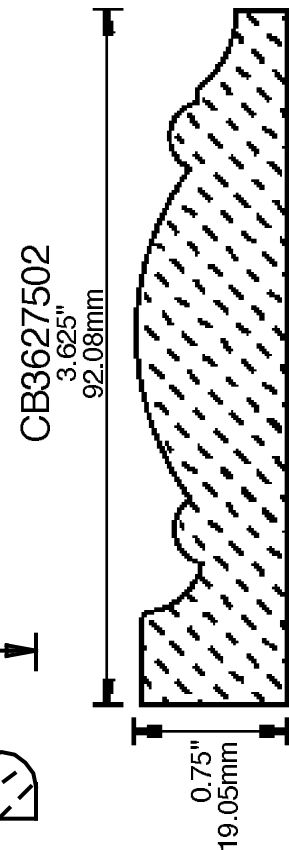
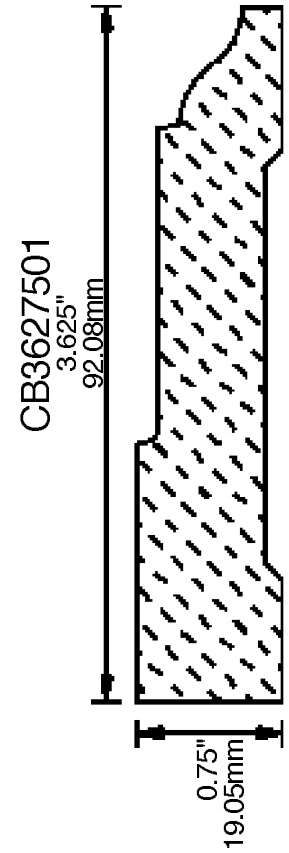
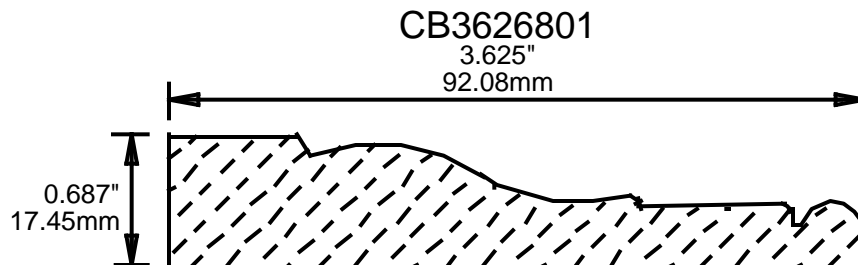
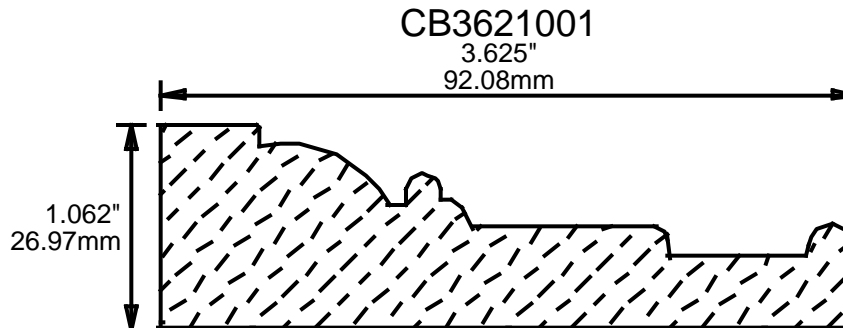
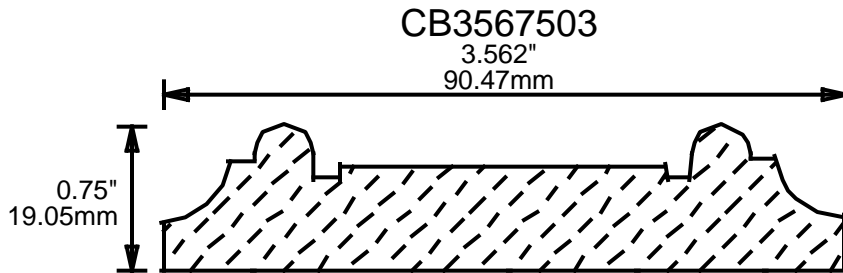
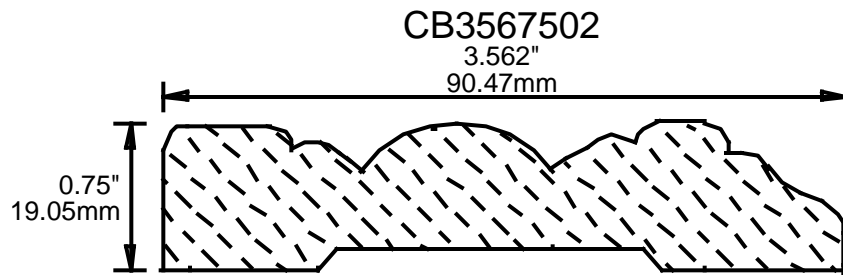
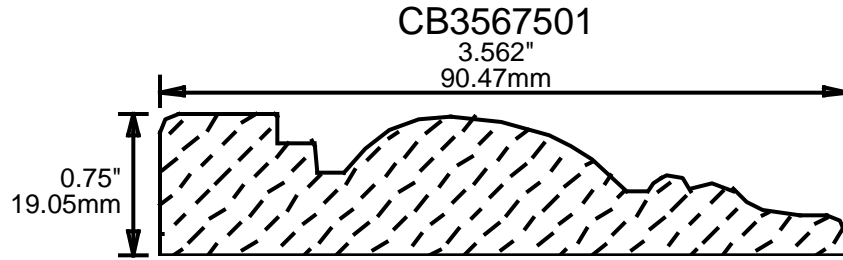
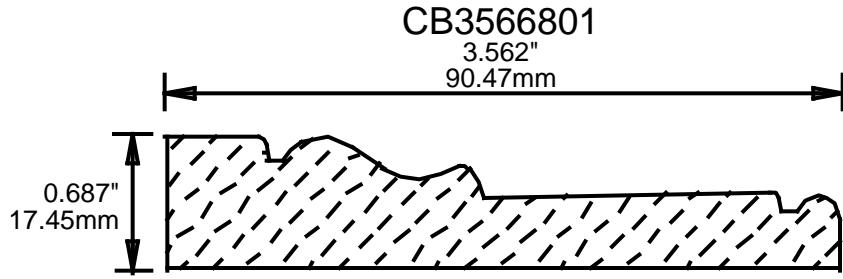

# WEINIG CASING AND BASE PATTERNS

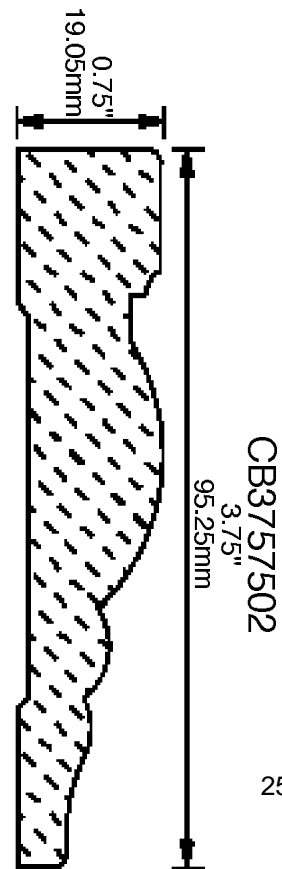
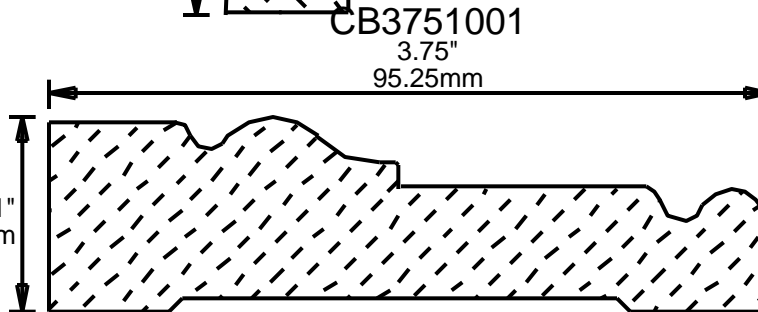
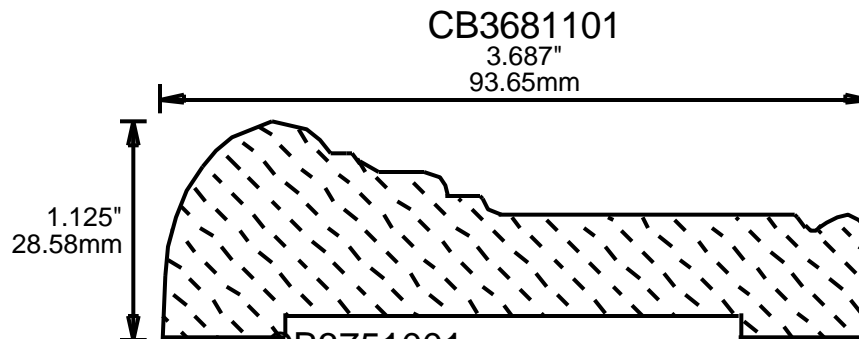
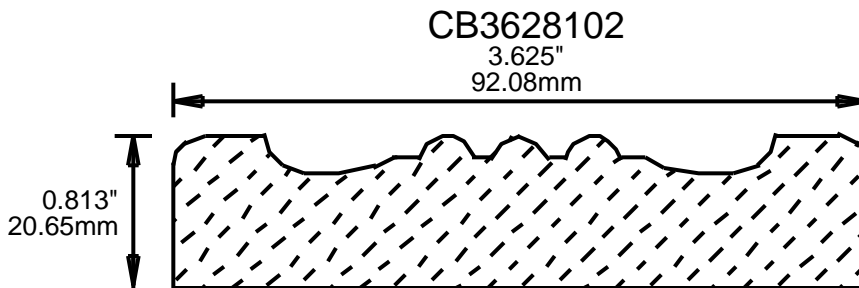
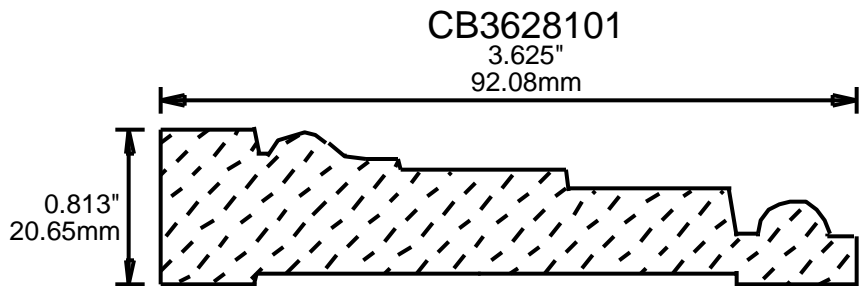
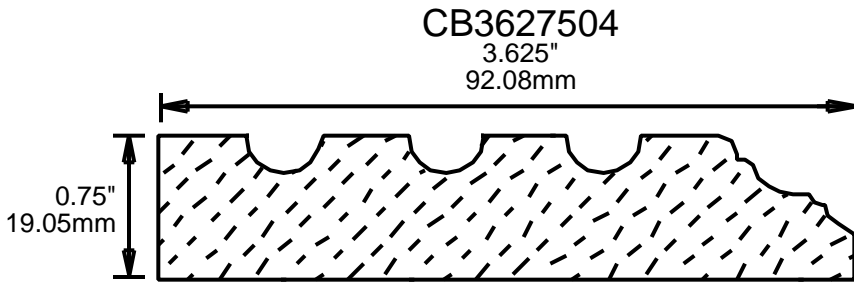
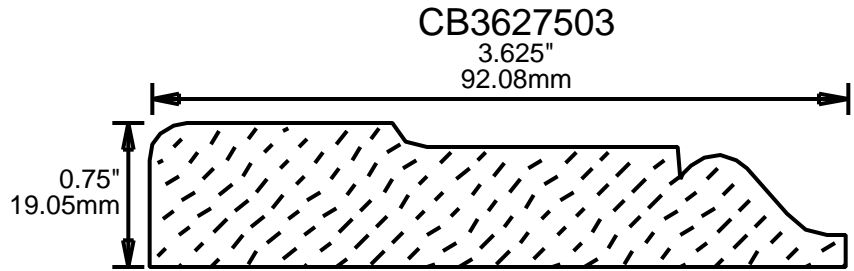
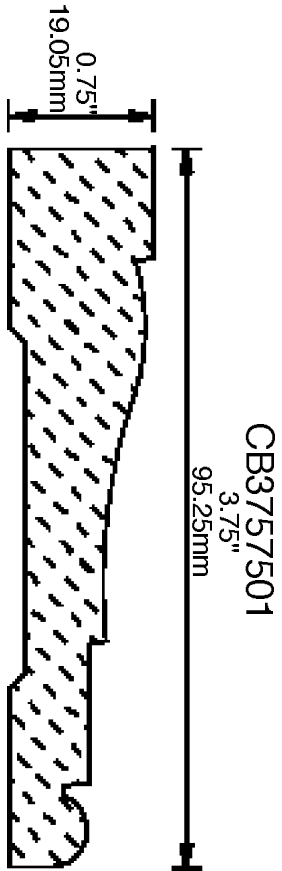



# WEINIG CASING AND BASE PATTERNS

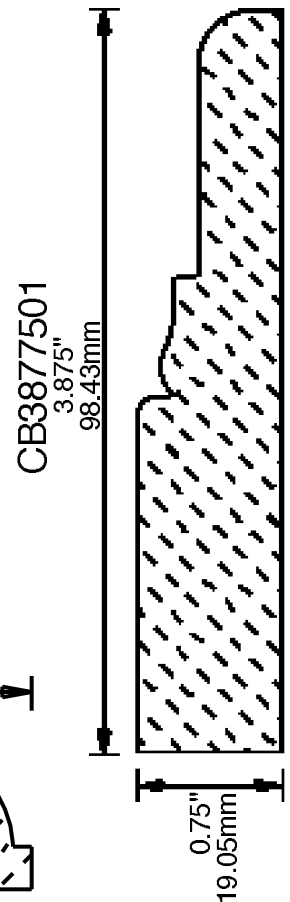
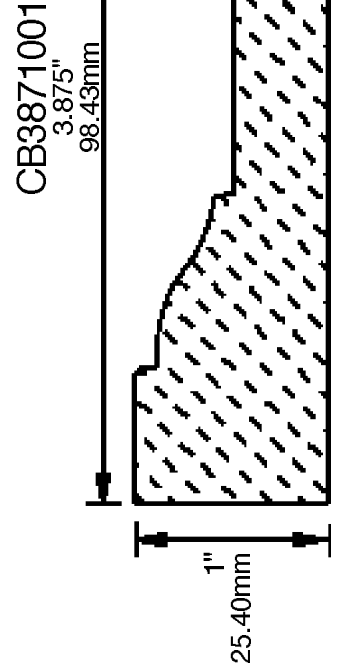
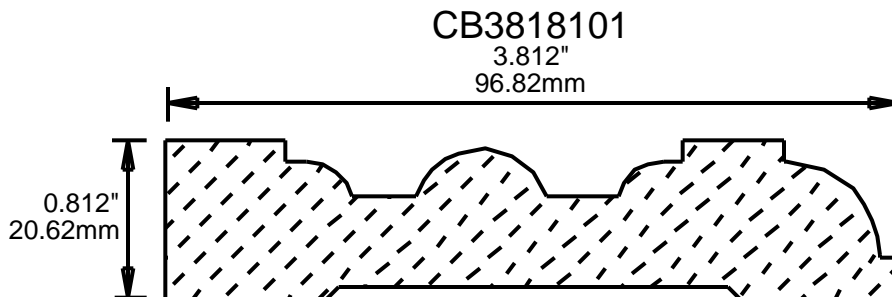
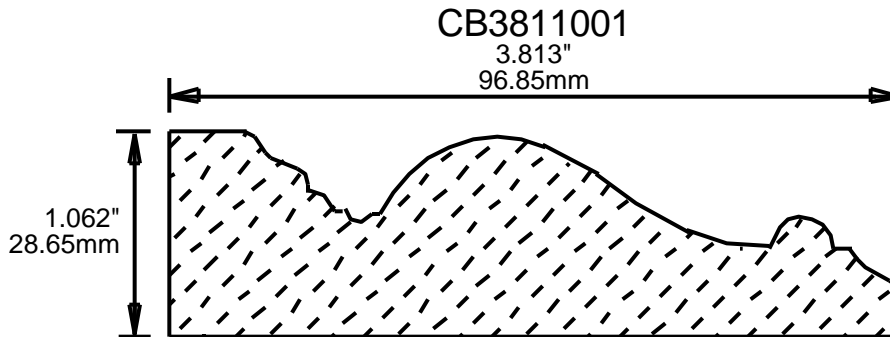
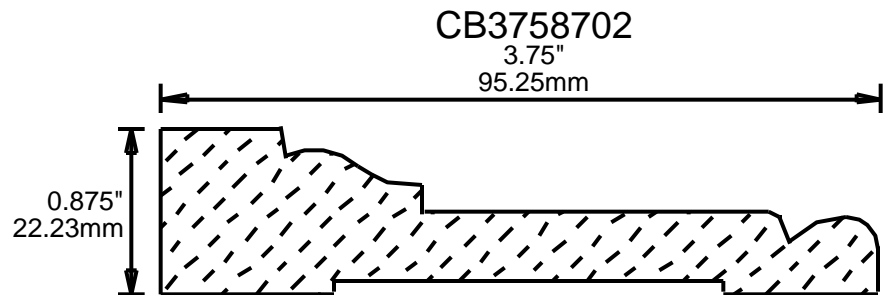
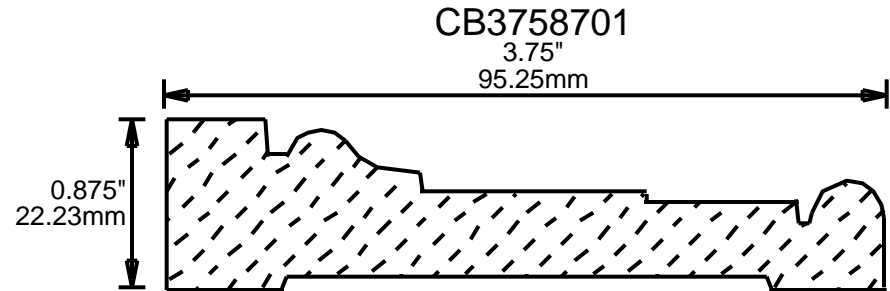
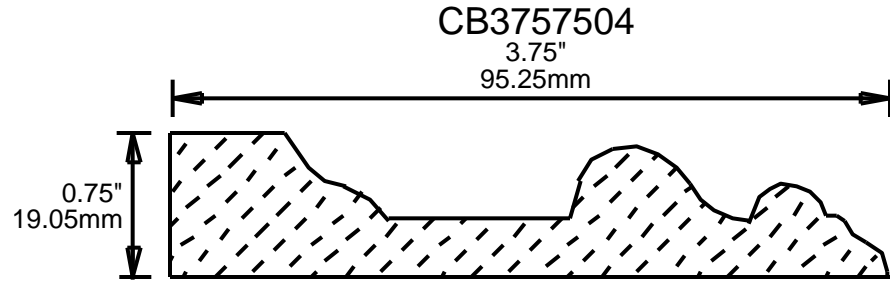
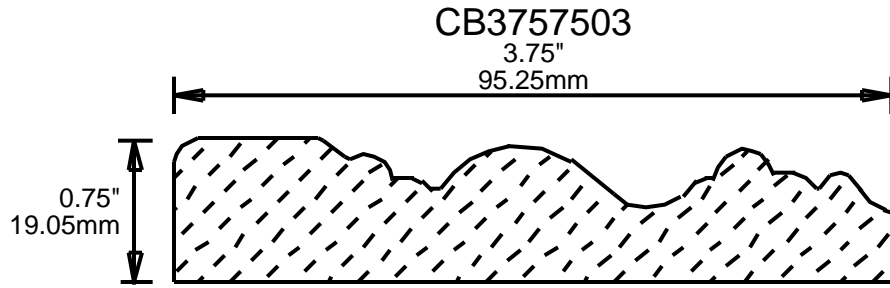

**PRINT  
THIS SECTION**

**RETURN TO  
Table of Contents**

# WEINIG CASING AND BASE PATTERNS

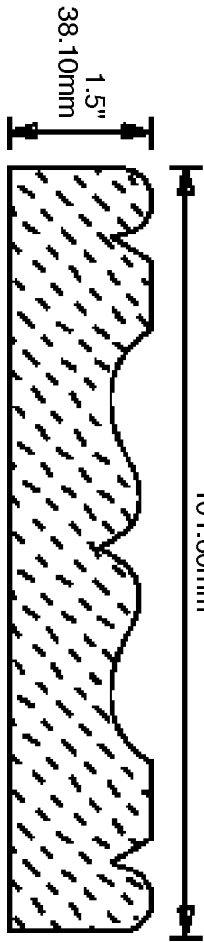

CB4007500  
4"

CB3871301

3.875"  
98.43mm

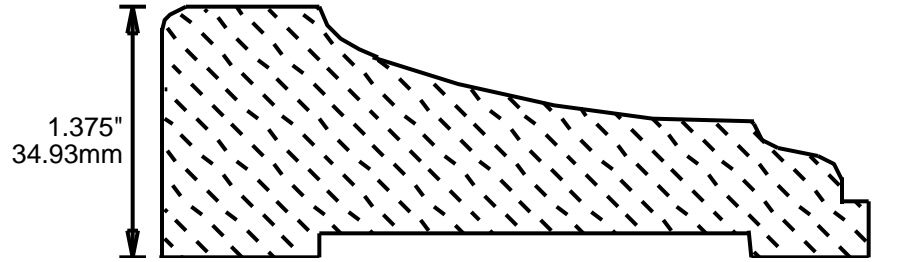

CB4001001

4"  
101.60mm

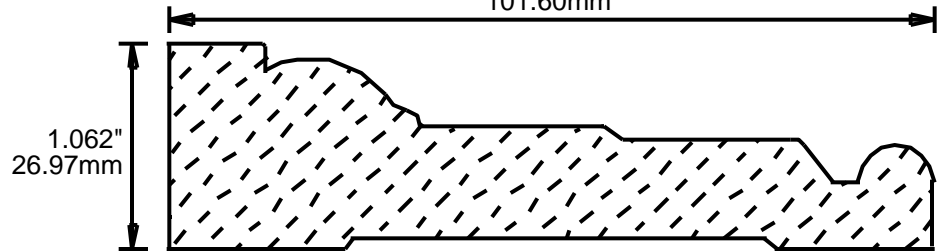

CB4001002

4"  
101.60mm

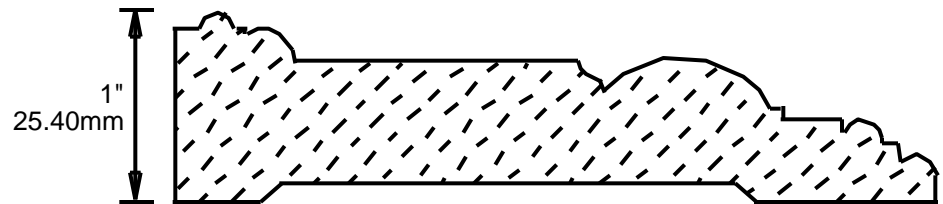

CB4005601

4"  
101.60mm



CB4006201

4"  
101.60mm

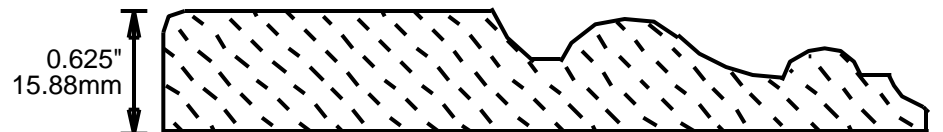

# WEINIG CASING AND BASE PATTERNS

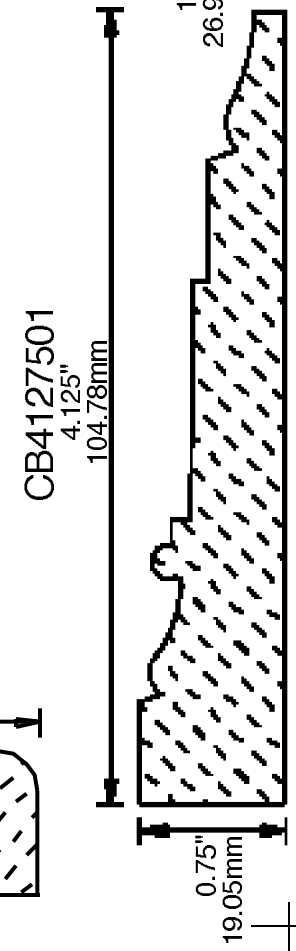
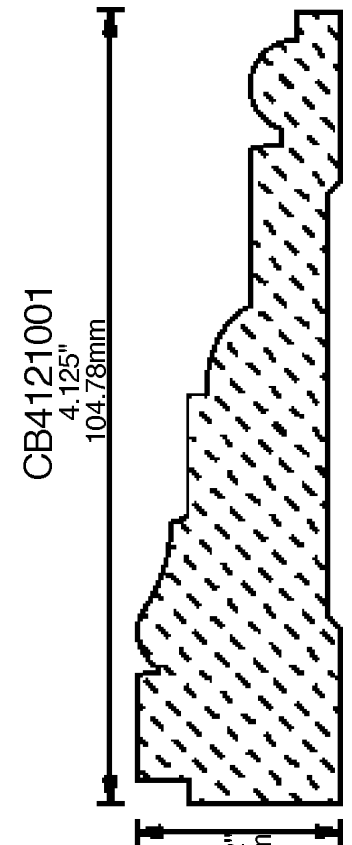
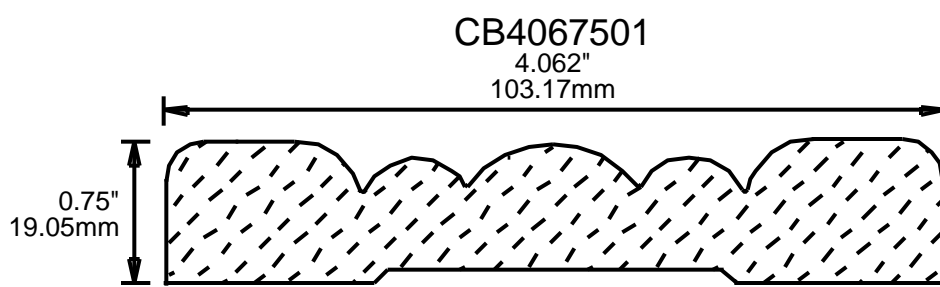
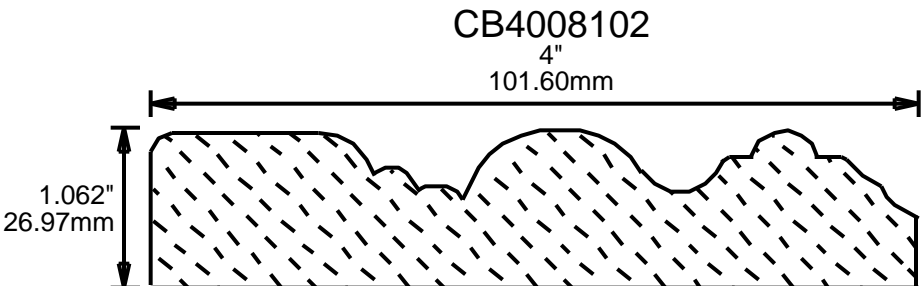
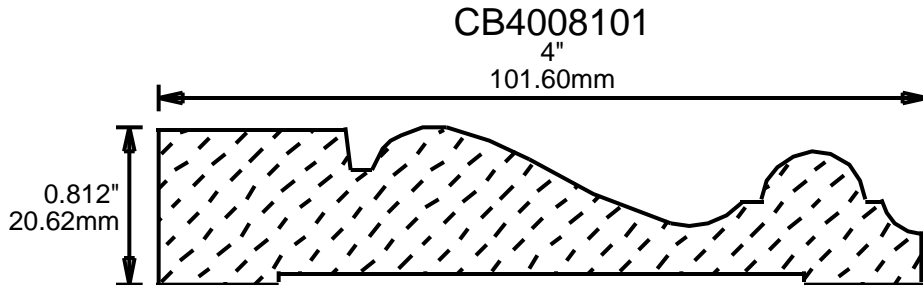
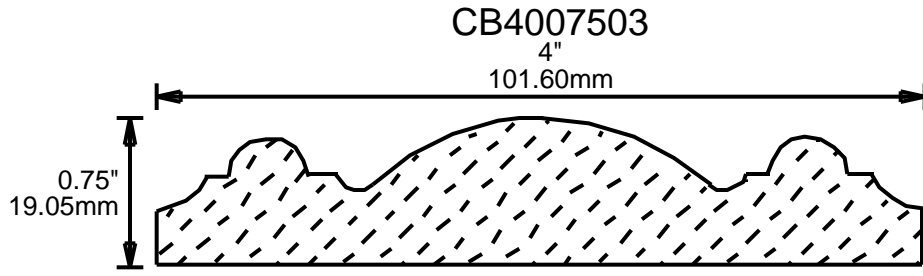
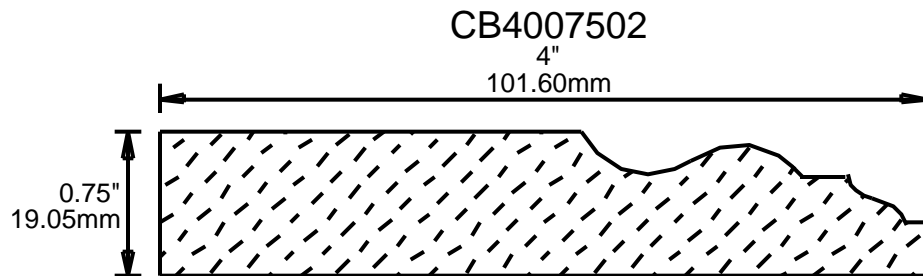
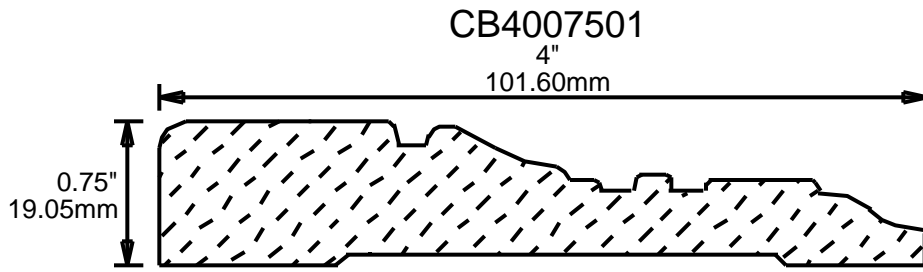

**PRINT THIS SECTION**

**RETURN TO Table of Contents**

# WEINIG CASING AND BASE PATTERNS

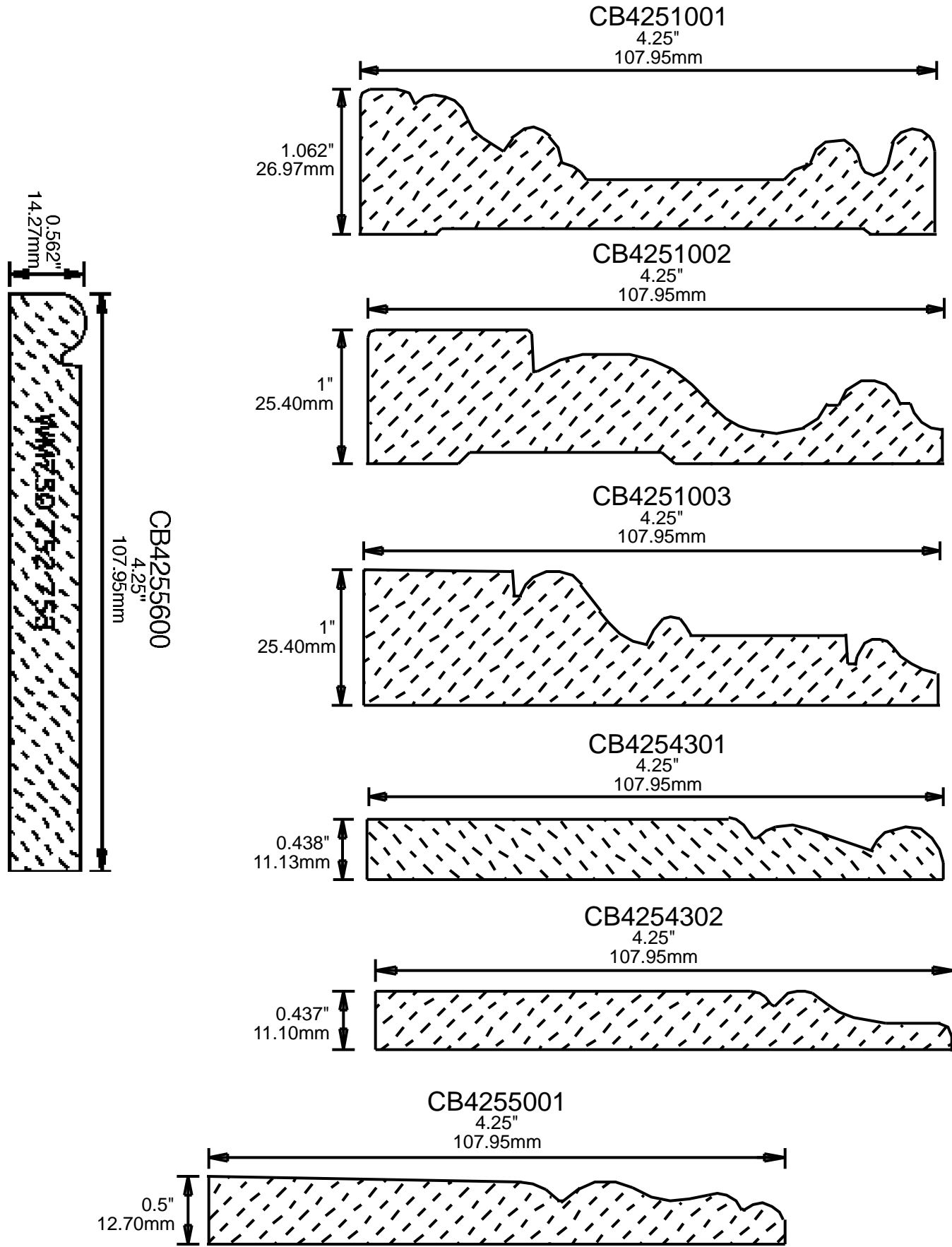

# WEINIG CASING AND BASE PATTERNS

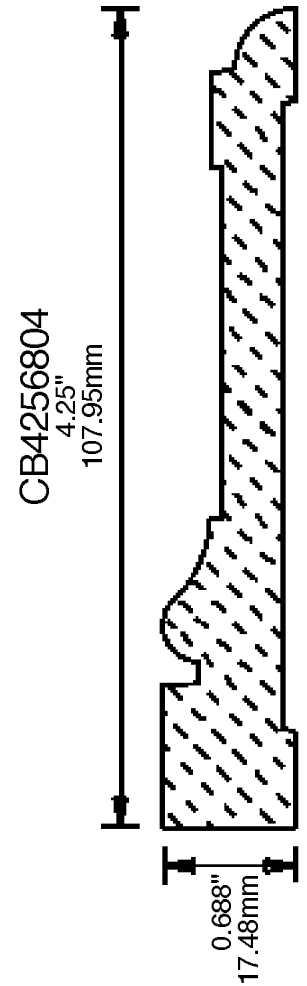
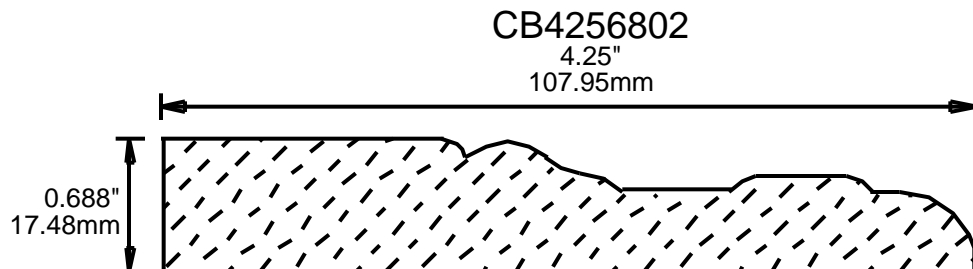
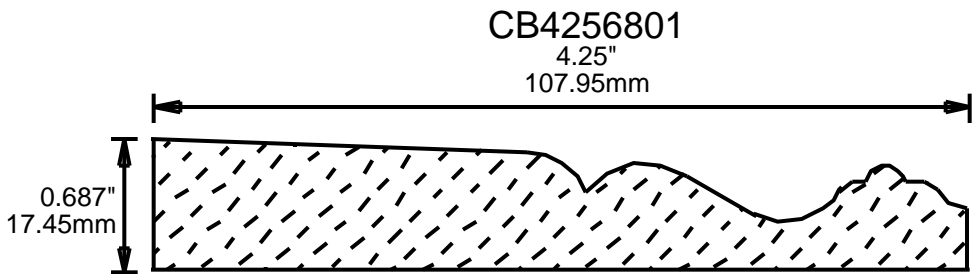
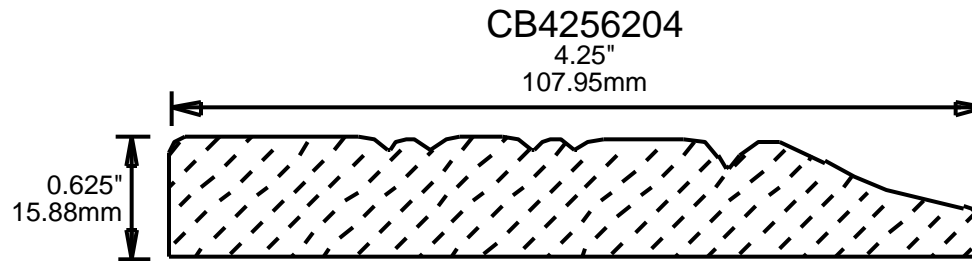
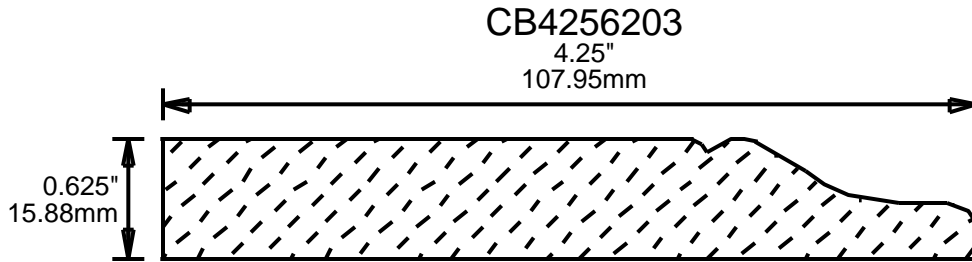
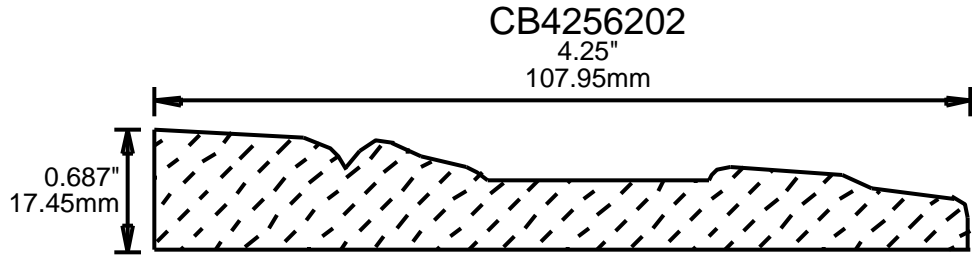
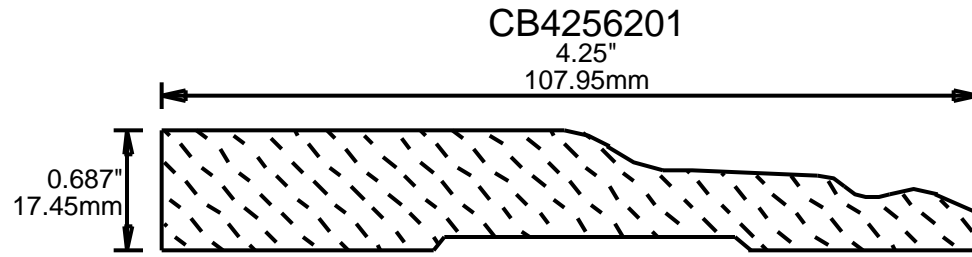

**PRINT  
THIS SECTION**

**RETURN TO  
Table of Contents**

# WEINIG CASING AND BASE PATTERNS

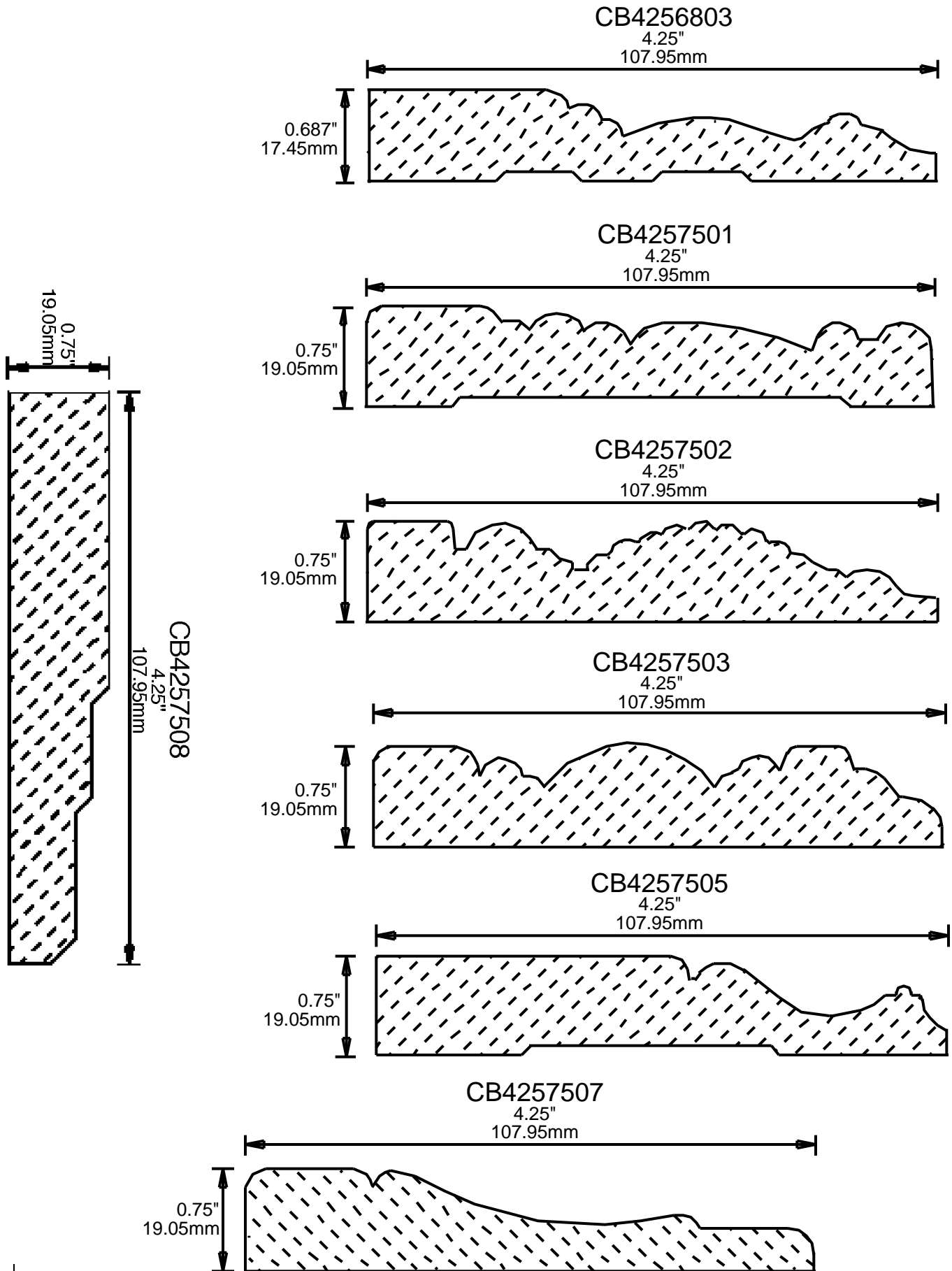

# WEINIG CASING AND BASE PATTERNS

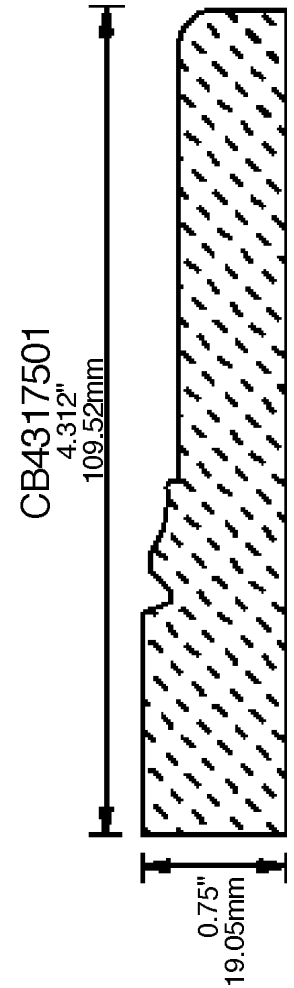
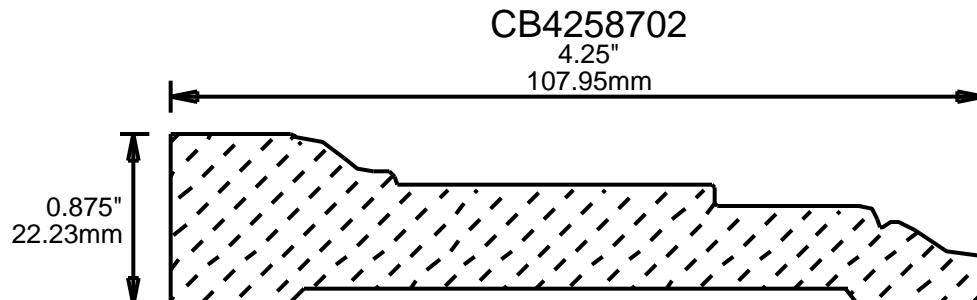
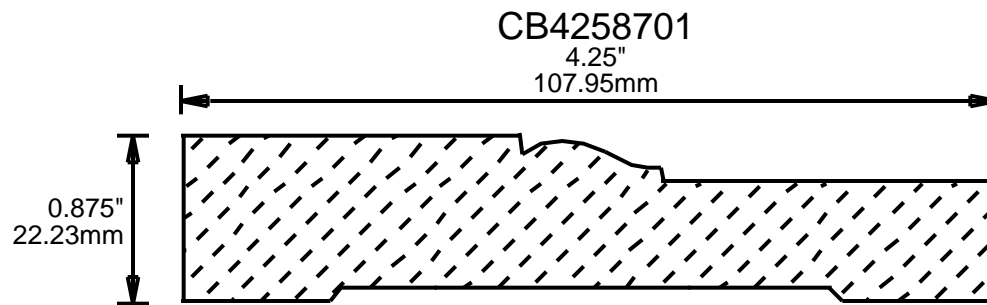
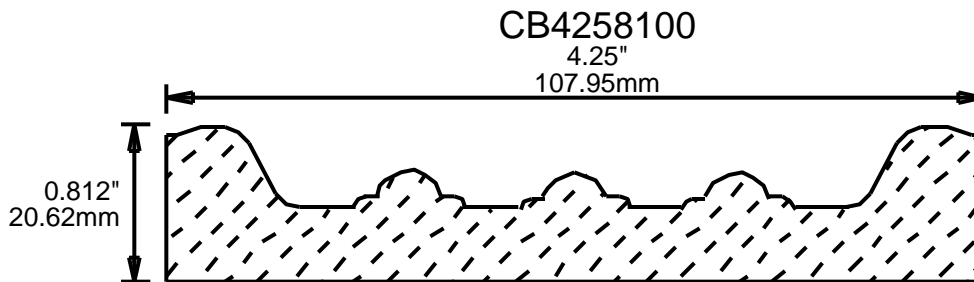
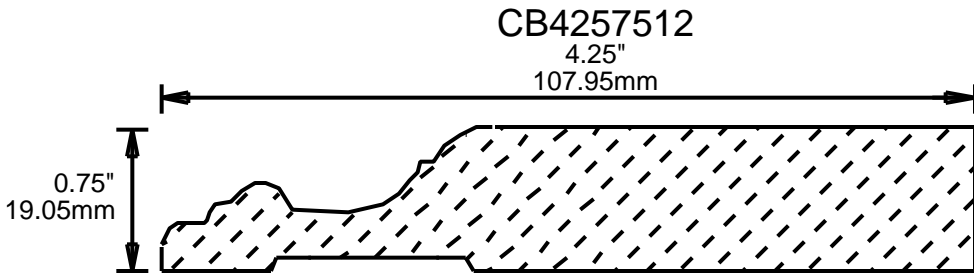
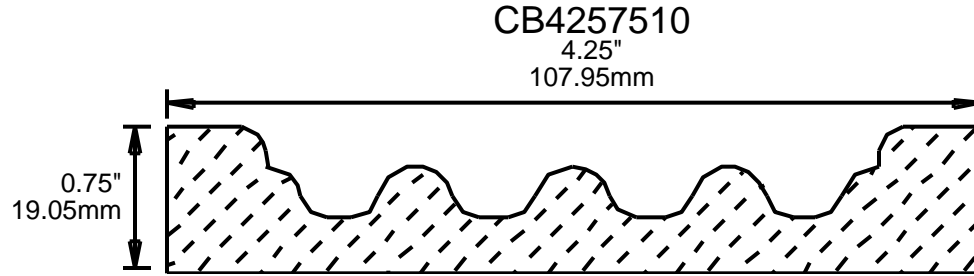
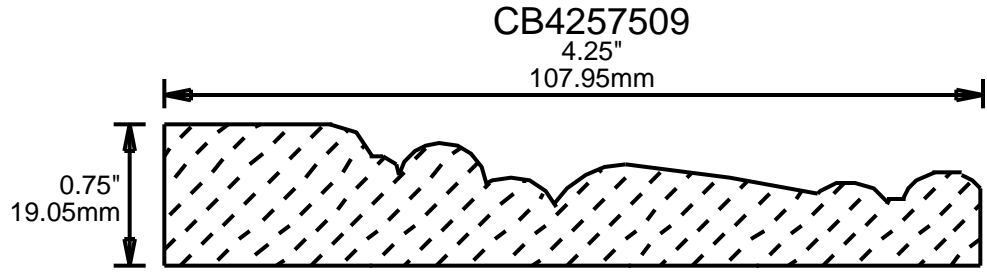

# WEINIG CASING AND BASE PATTERNS

CB4317502

4.312"  
109.52mm

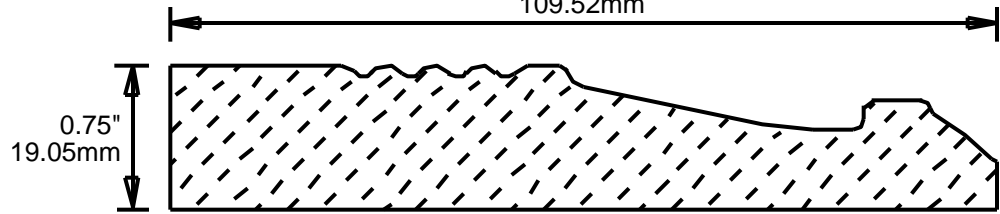

CB4377504

4.375"  
111.13mm

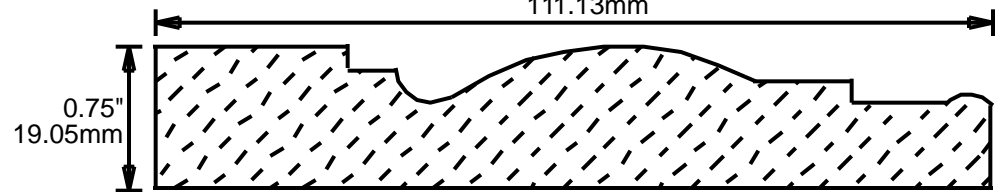

CB4435001

4.437"  
112.70mm

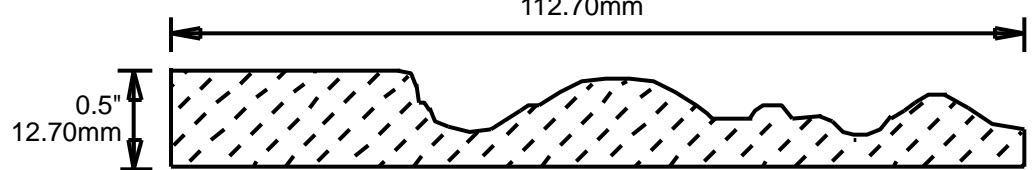

CB4436201

4.437"  
112.70mm

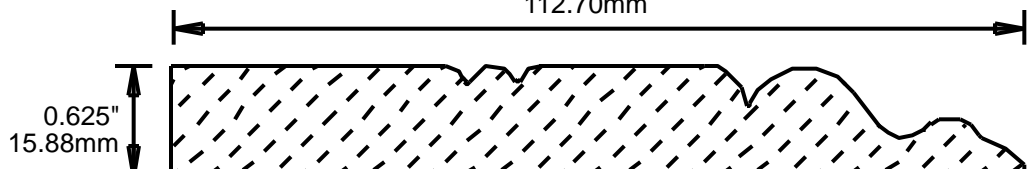

CB4501001

4.5"  
114.30mm

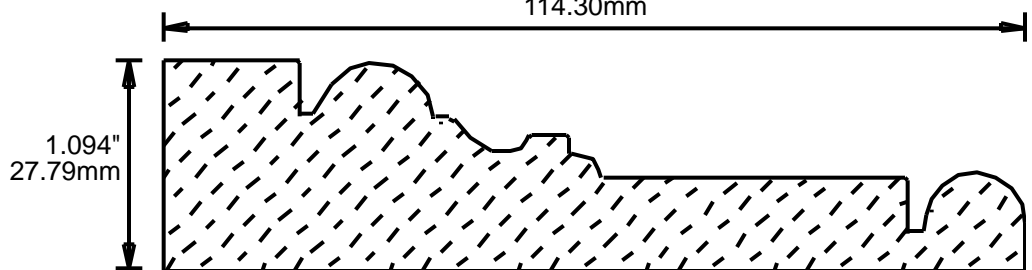

CB4501002

4.5"  
114.30mm

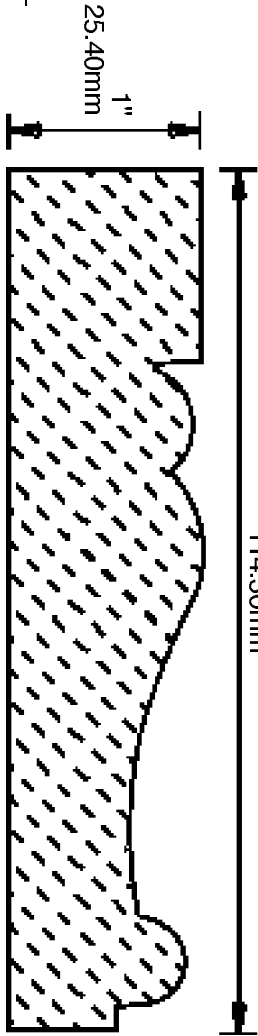
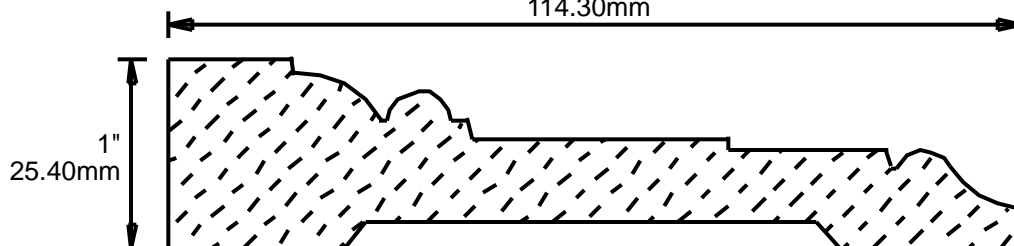

CB4501003

4.5"

114.30mm



# WEINIG CASING AND BASE PATTERNS

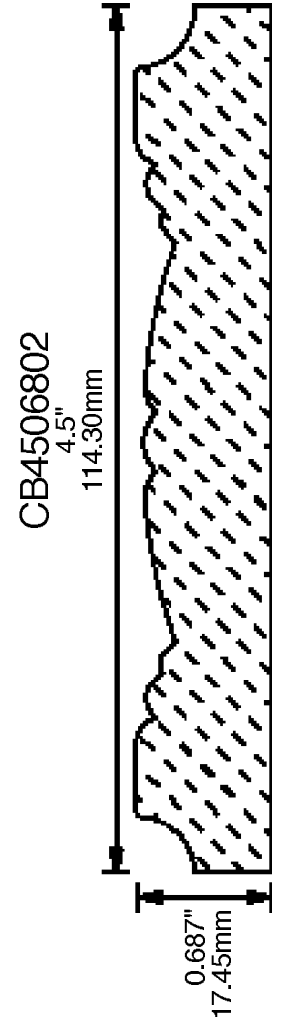
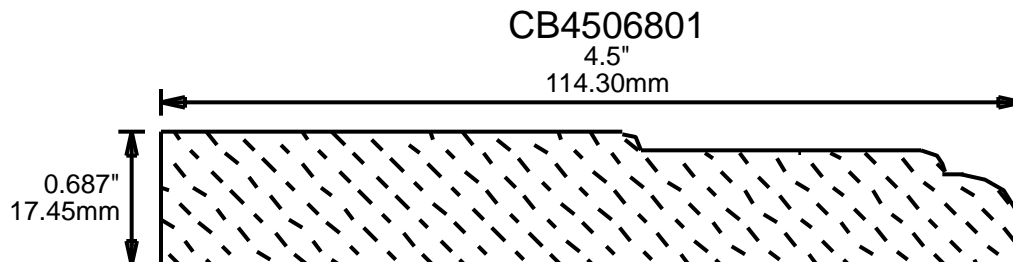
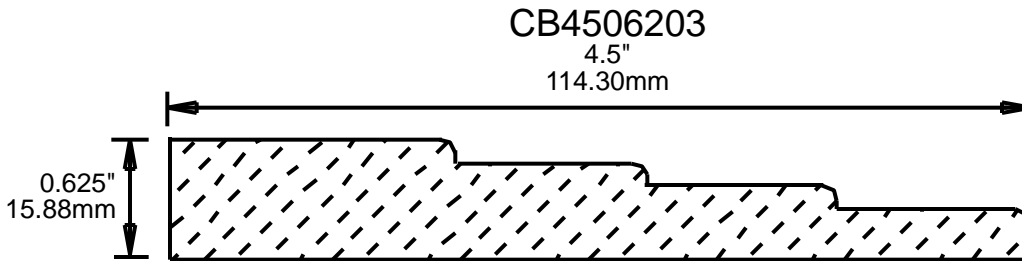
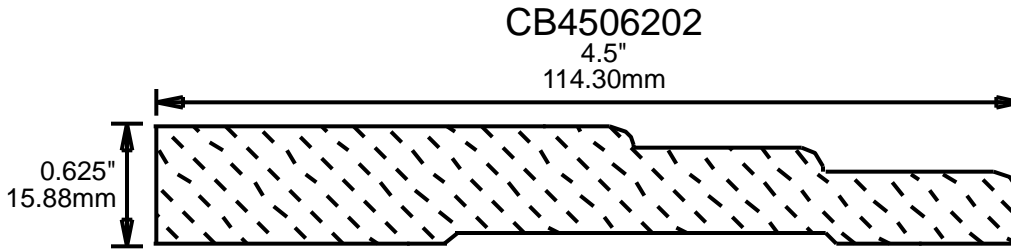
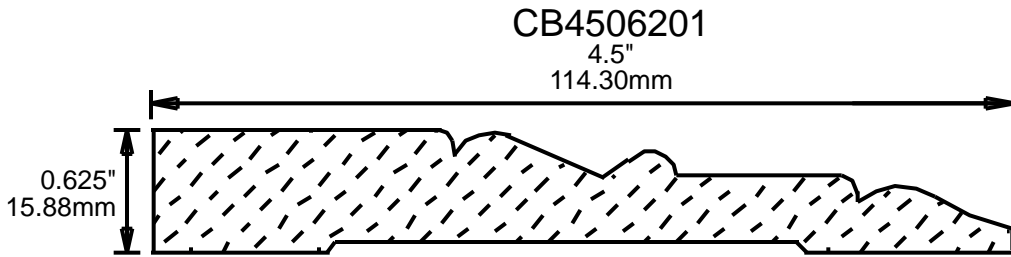
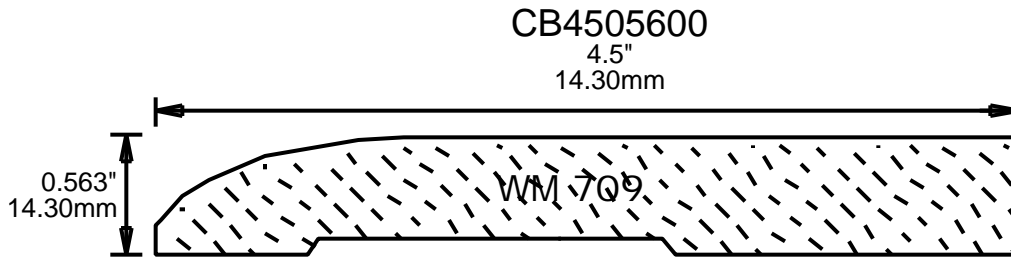
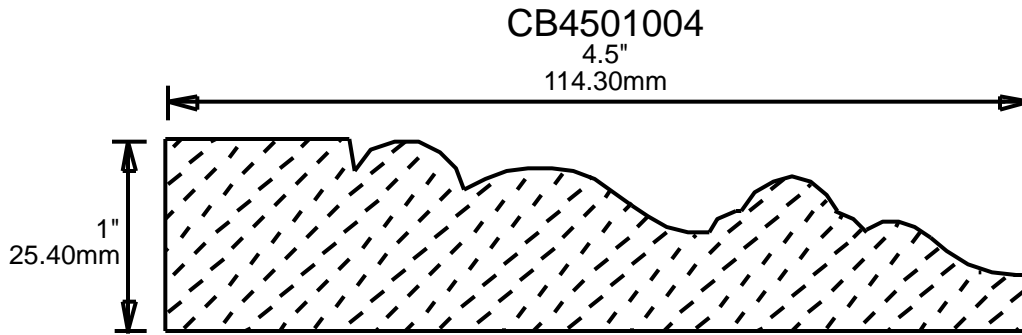

# WEINIG CASING AND BASE PATTERNS

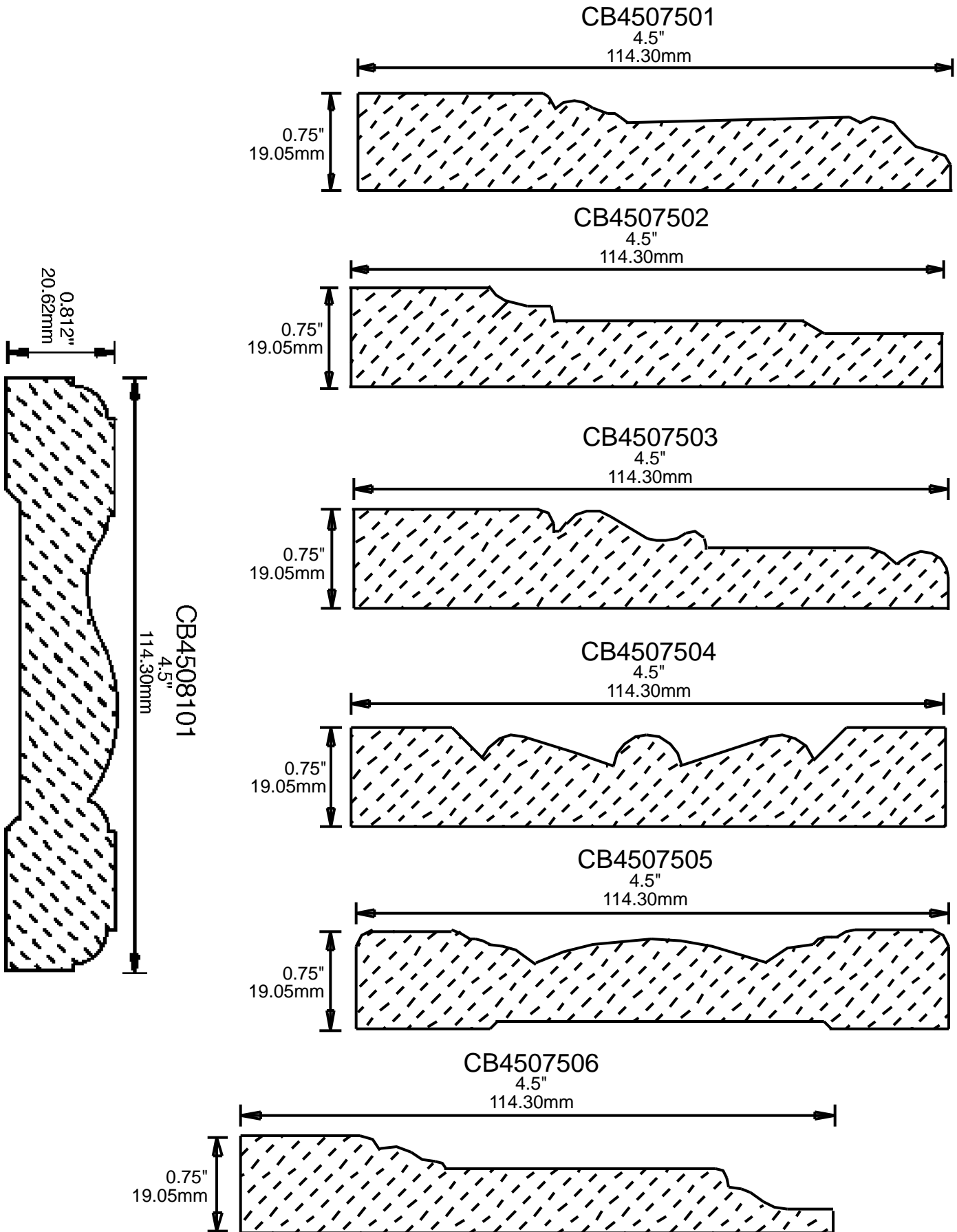

# WEINIG CASING AND BASE PATTERNS

CB4508701

4.5"

114.30mm

0.875"  
22.23mm

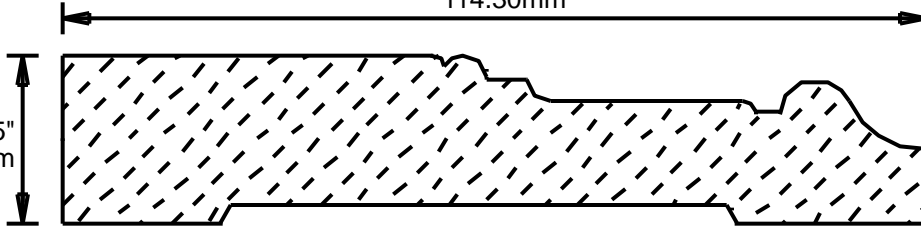

CB4537501

4.5"

114.30mm

0.75"  
19.05mm

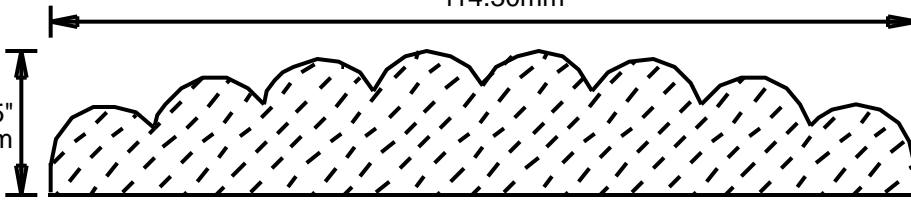

CB4561001

4.563"

115.90mm

1"  
25.40mm

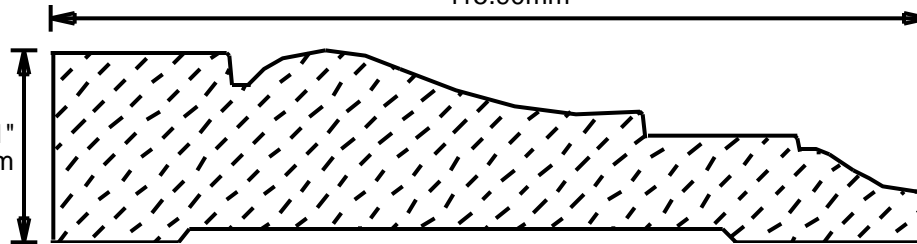

CB4569300

4.562"

115.87mm

0.938"  
23.83mm

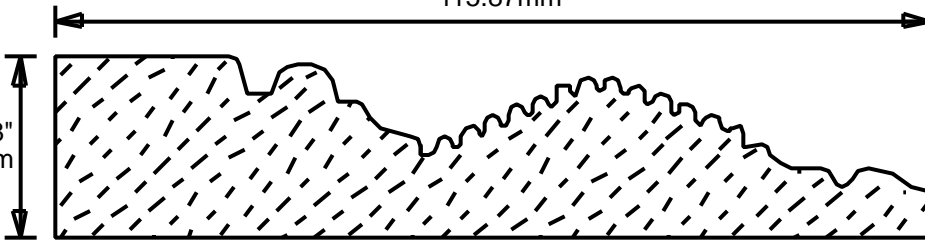

CB4751001

4.75"

120.65mm

1"  
25.40mm

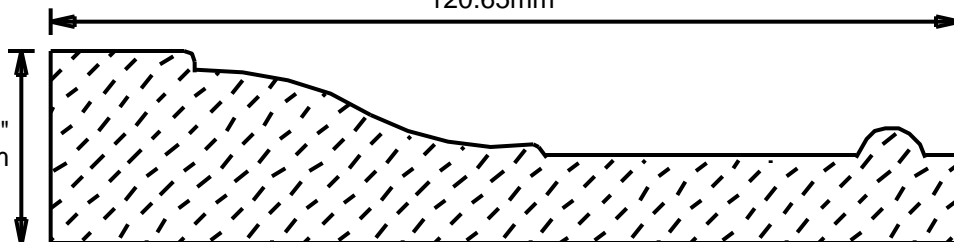

CB4751002

4.75"

120.65mm

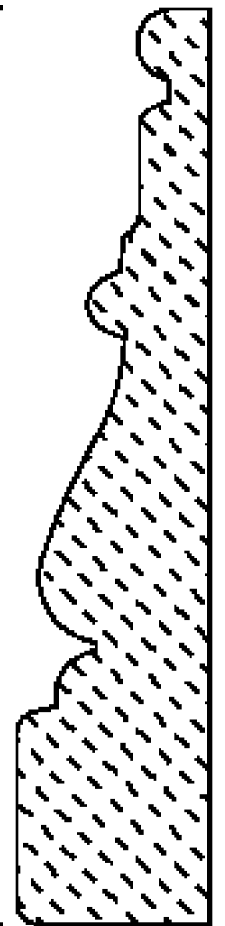

1"  
25.40mm

**PRINT  
THIS SECTION**

**RETURN TO  
Table of Contents**

# WEINIG CASING AND BASE PATTERNS

CB4757500

4.75"  
120.65mm

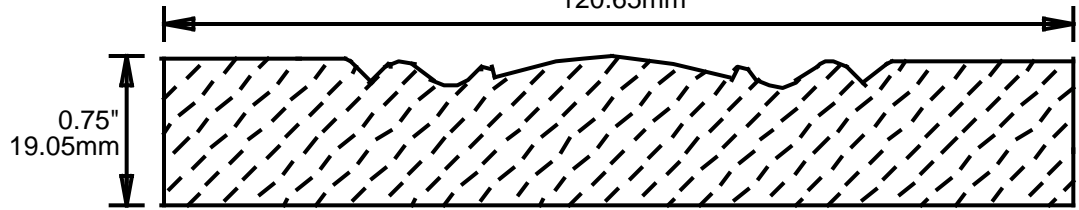

CB4757501

4.75"  
120.65mm

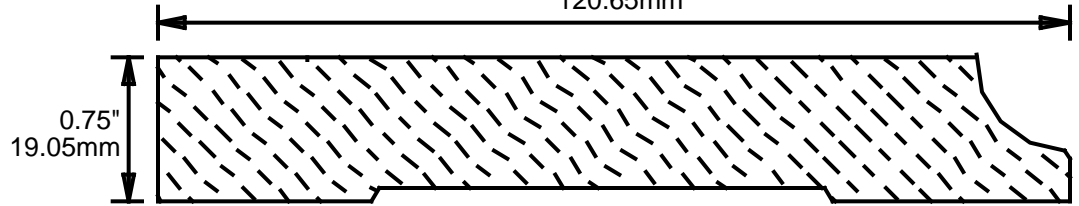

CB4871201

4.875"  
123.83mm

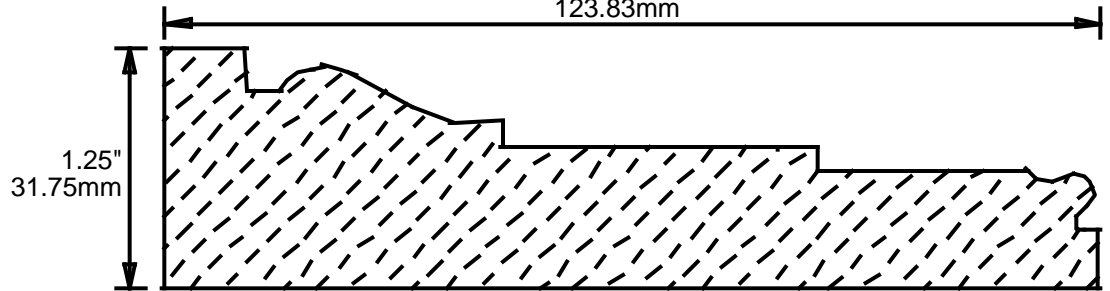

CB4877501

4.875"  
123.83mm

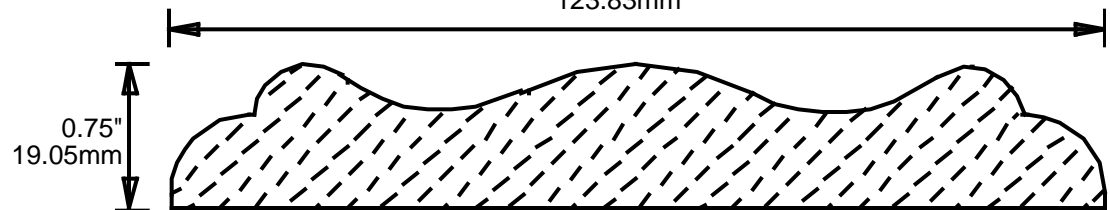

CB5001101

5"  
127.00mm

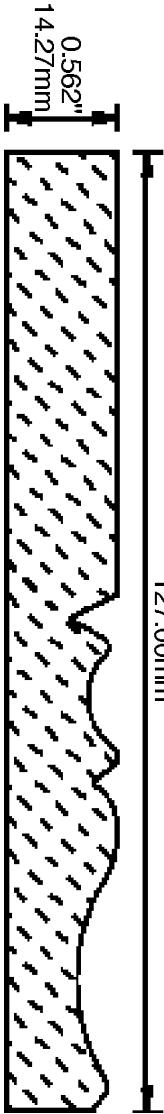
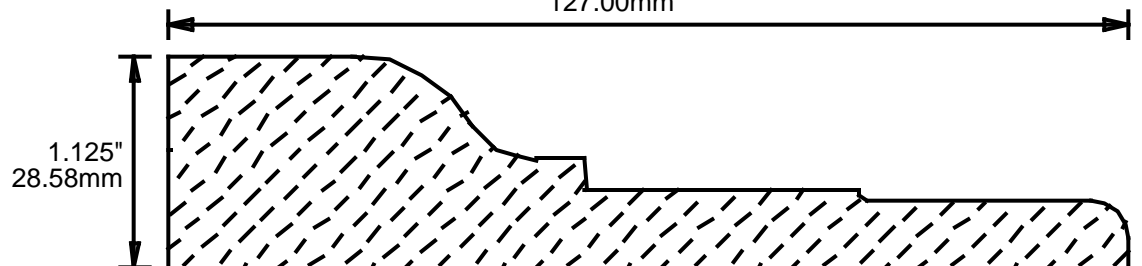

CB5005601

5"  
127.00mm

# WEINIG CASING AND BASE PATTERNS

CB5006801

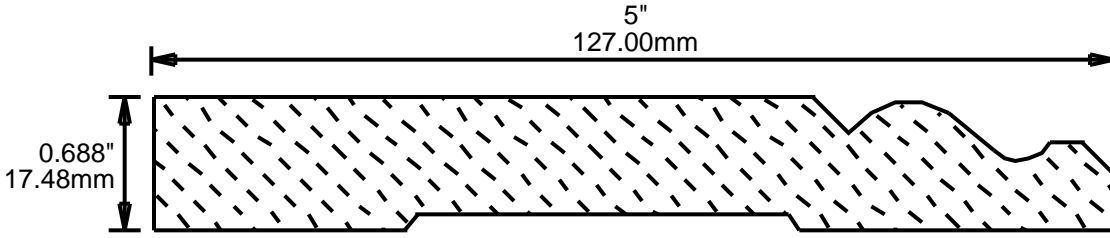

CB5006802

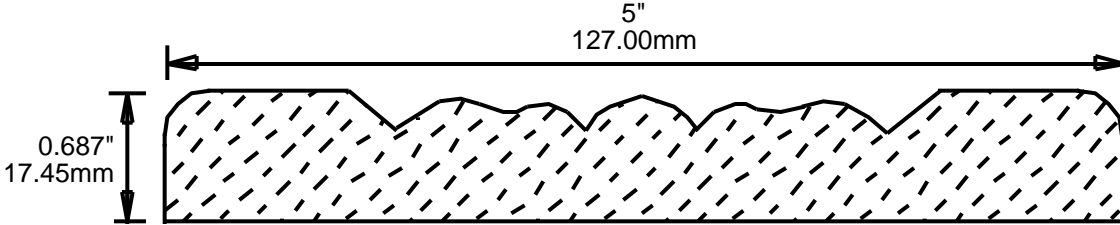

CB5007501

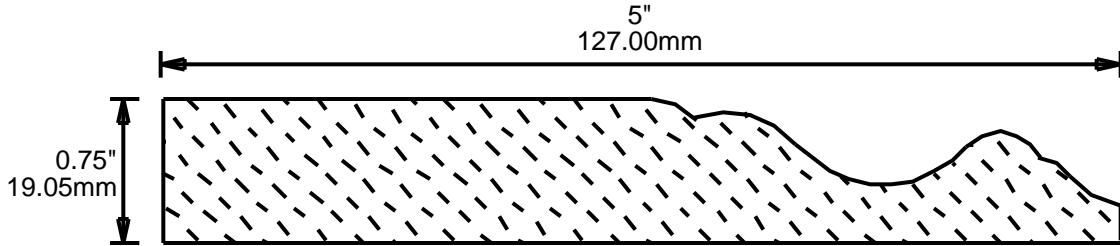

CB5007502

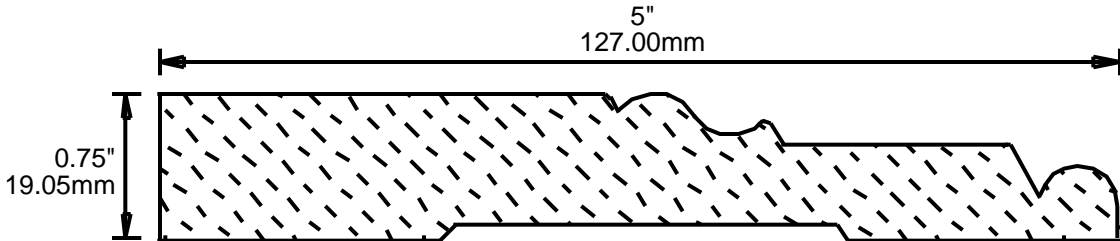

CB5007503

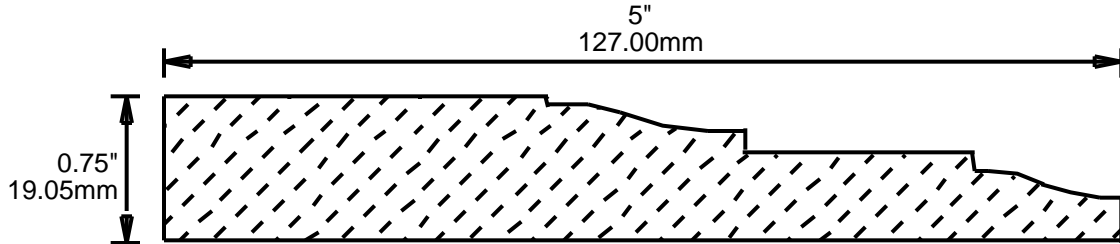

CB5008101

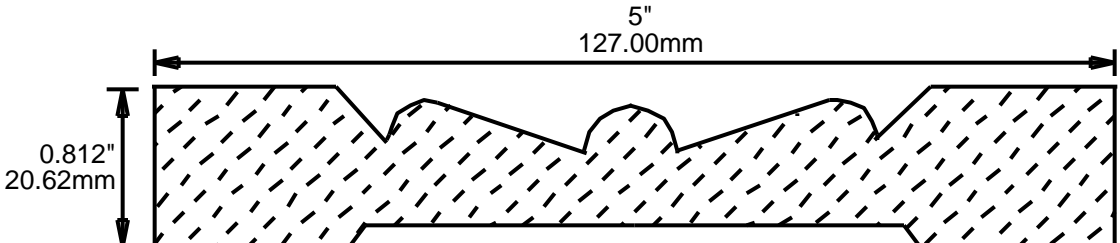

# WEINIG CASING AND BASE PATTERNS

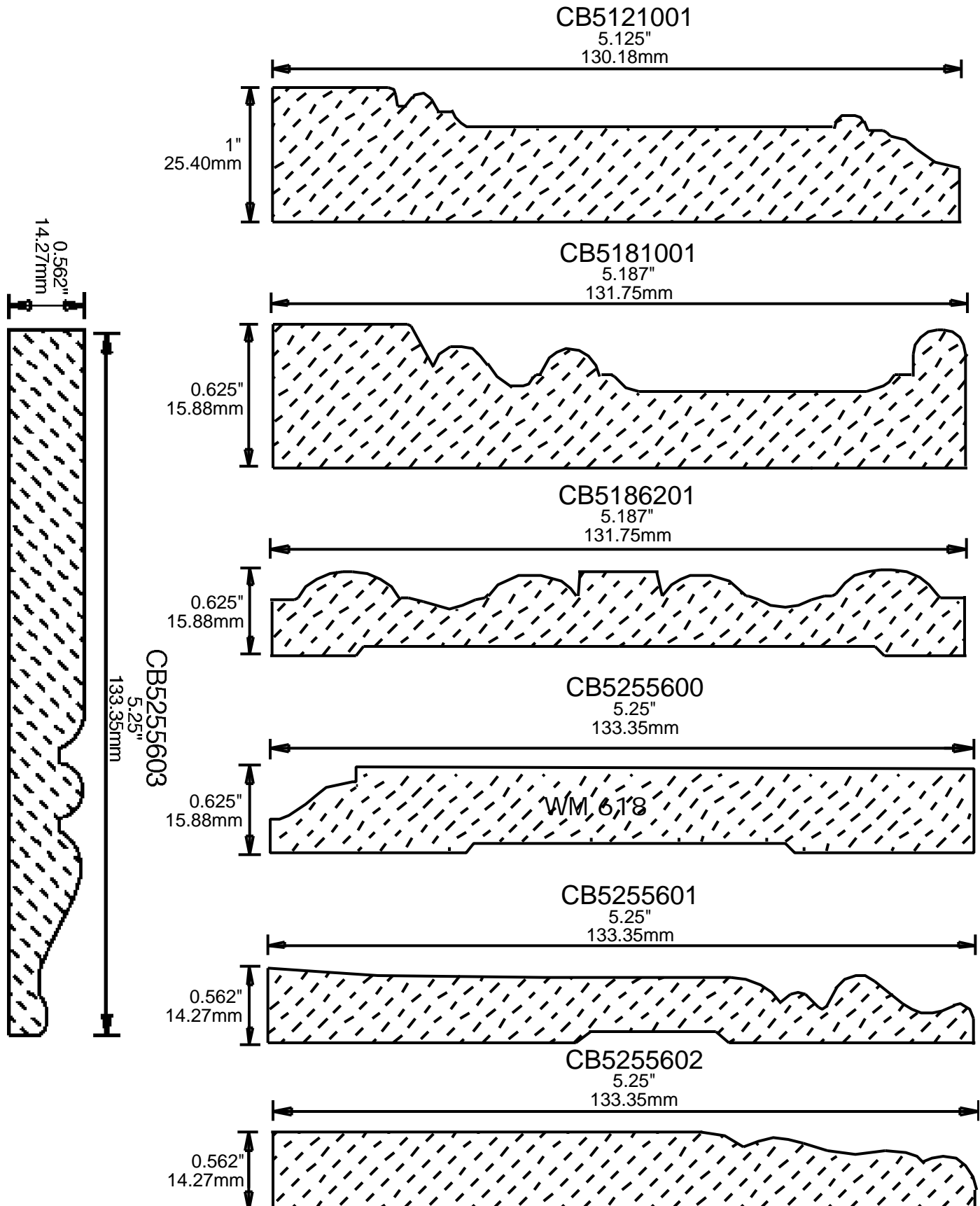

# WEINIG CASING AND BASE PATTERNS

CB5255604

5.25"  
133.35mm

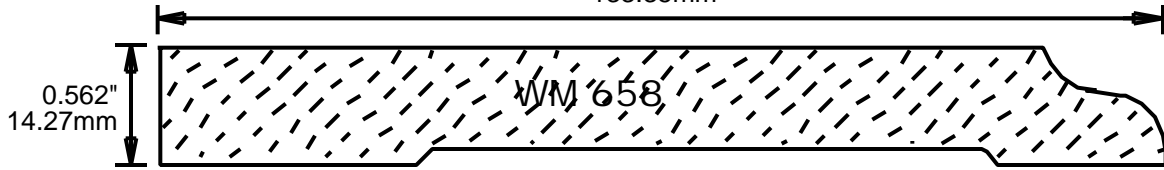

CB5256201

5.25"  
133.35mm

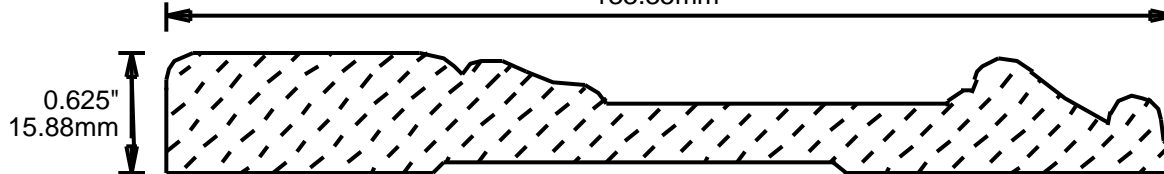

CB5256202

5.25"  
133.35mm

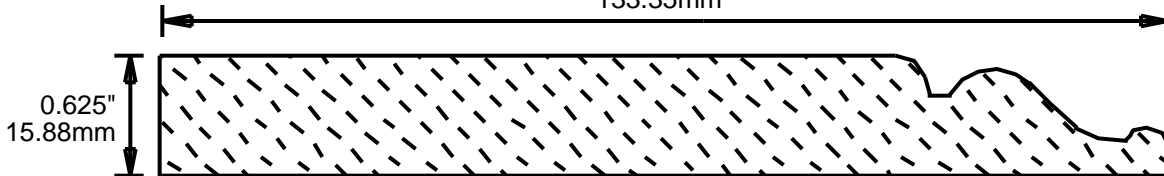

CB5256801

5.25"  
133.35mm

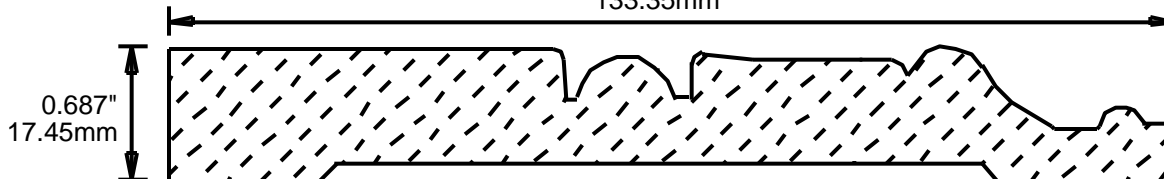

CB5256802

5.25"  
133.35mm

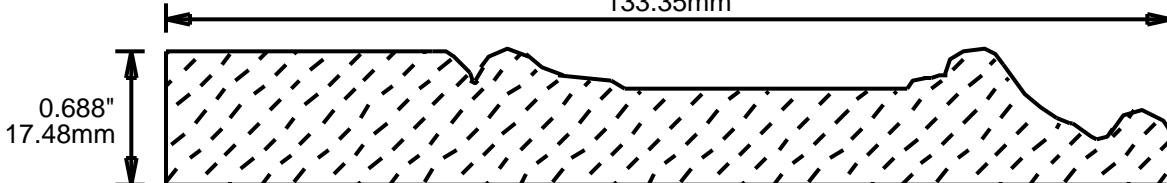

CB5256803

5.25"  
133.35mm

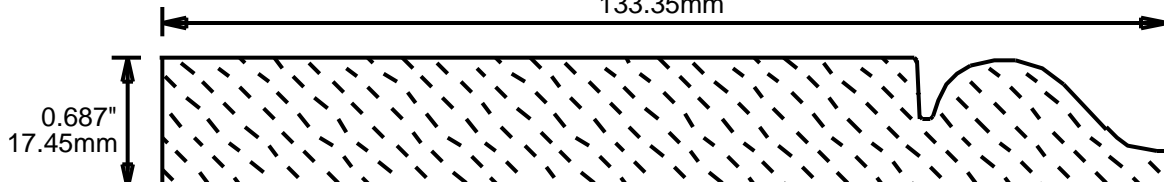

# WEINIG CASING AND BASE PATTERNS

CB5256804

5.25"

133.35mm

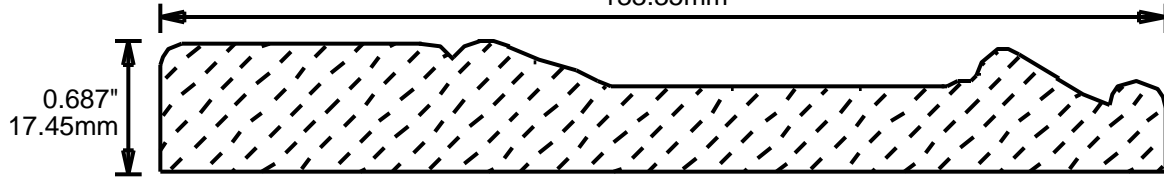

CB5256805

5.25"

133.35mm

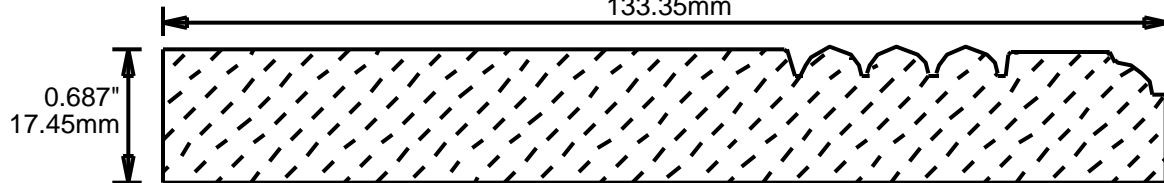

CB5256806

5.25"

133.35mm

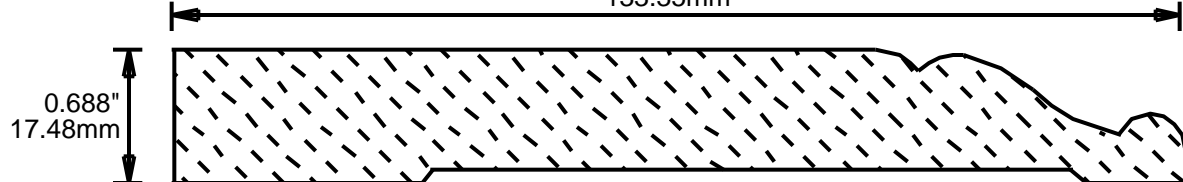

CB5256807

5.25"

133.35mm

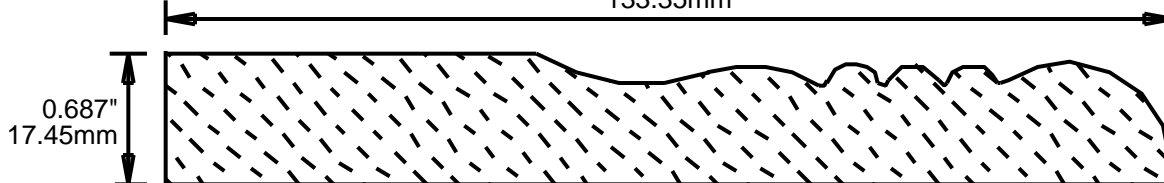

CB5256808

5.25"

133.35mm

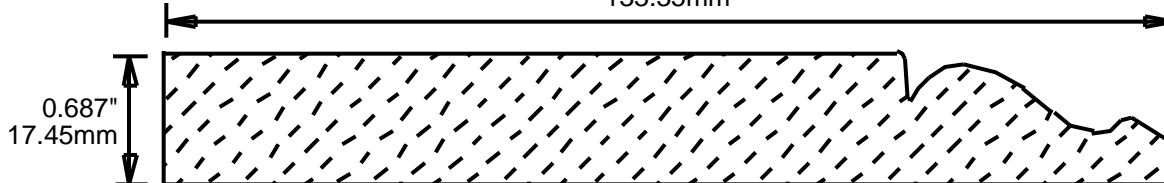

CB5257501

5.25"

133.35mm

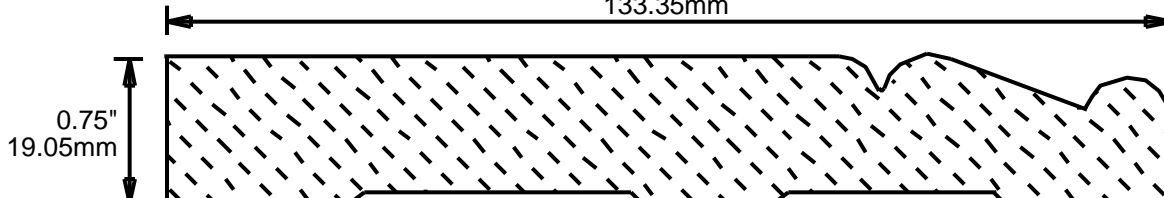



# WEINIG CASING AND BASE PATTERNS

CB5257502

5.25"  
133.35mm

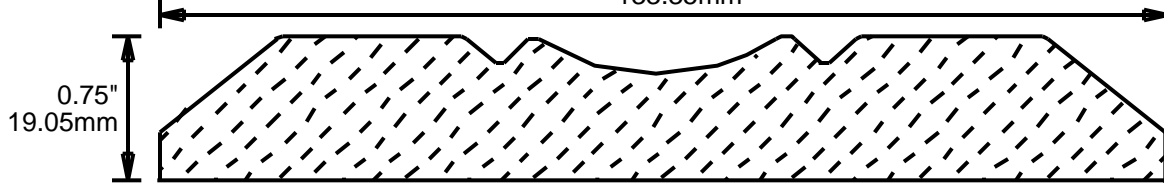

CB5257503

5.25"  
133.35mm

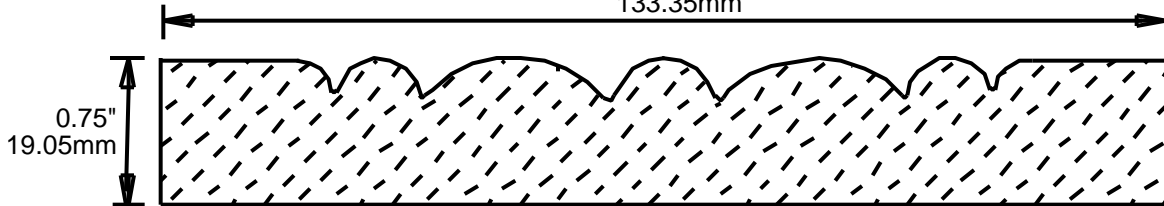

CB5311501

5.313"  
134.95mm

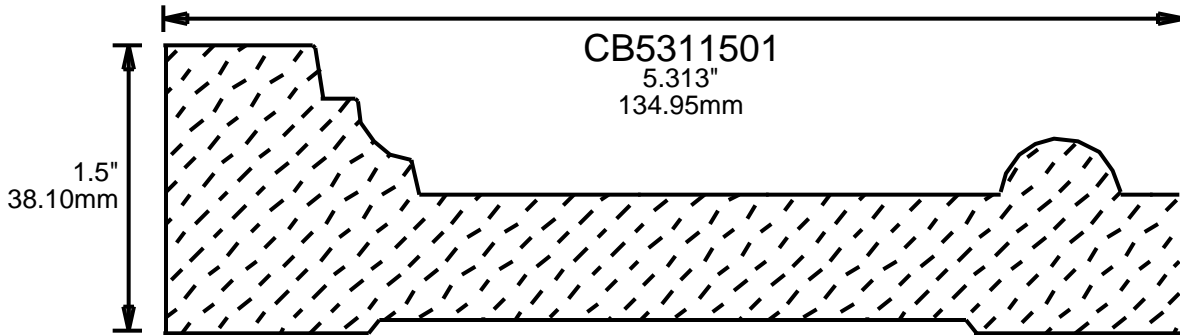

CB5317501

5.312"  
134.92mm

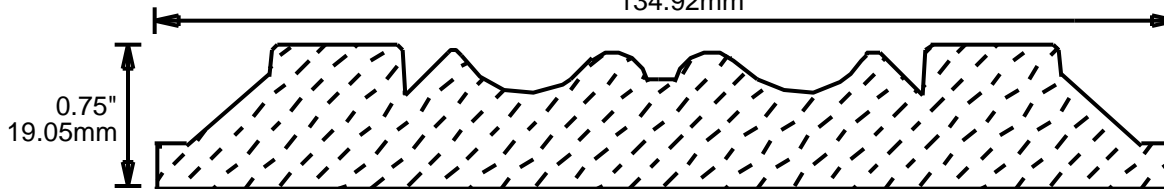

CB5378101

5.375"  
136.53mm

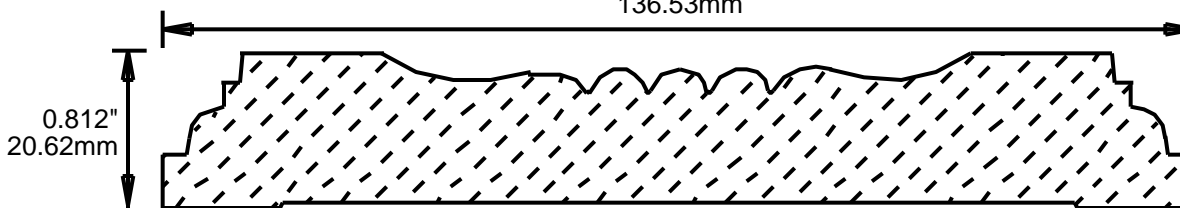

CB5437501

5.437"  
138.10mm

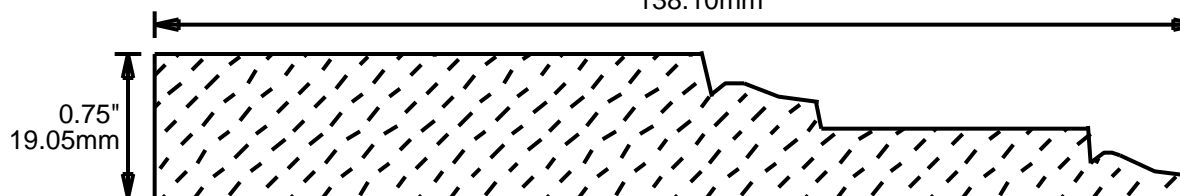

**PRINT  
THIS SECTION**

**RETURN TO  
Table of Contents**

# WEINIG CASING AND BASE PATTERNS

CB5435601

5.437"  
138.10mm

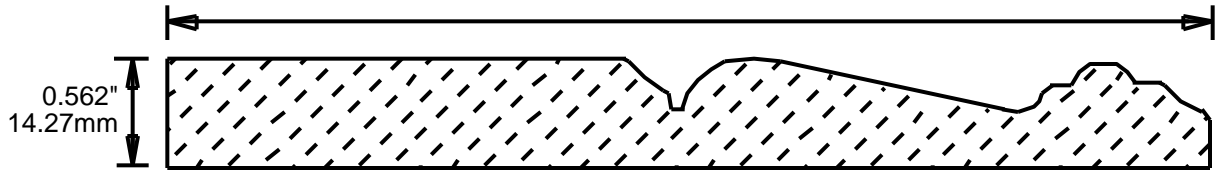

CB5438101

5.437"  
138.10mm

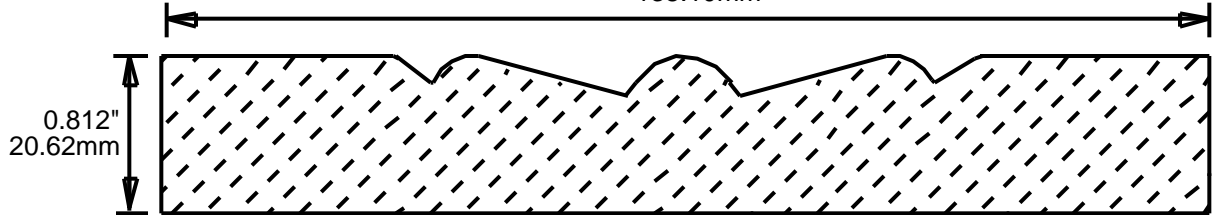

CB5501001

5.5"  
139.70mm

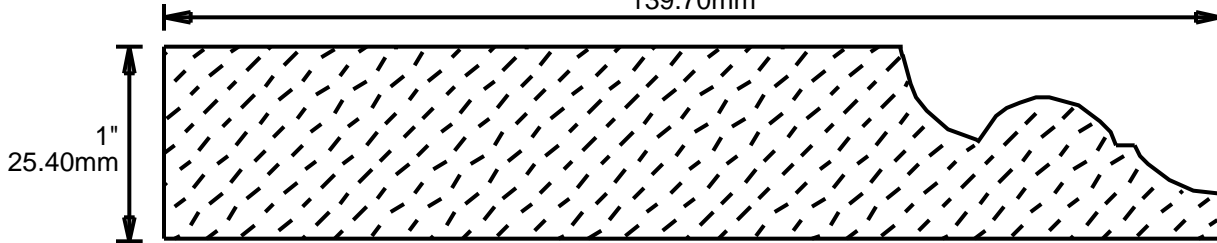

CB5501201

5.5"  
139.70mm

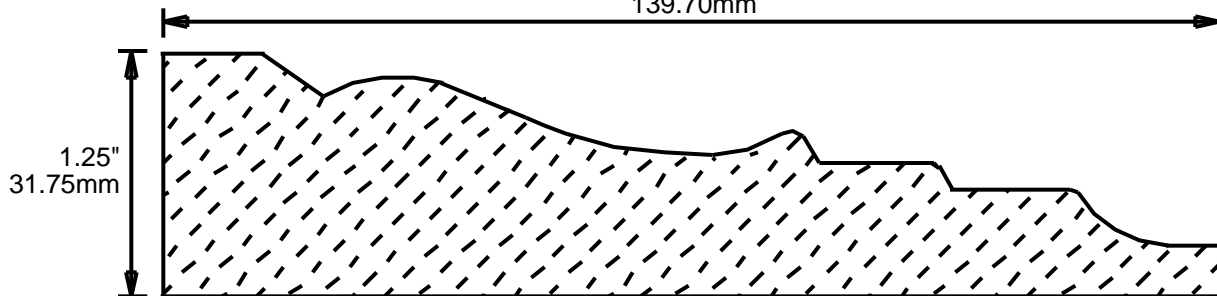

CB5506201

5.5"  
139.70mm

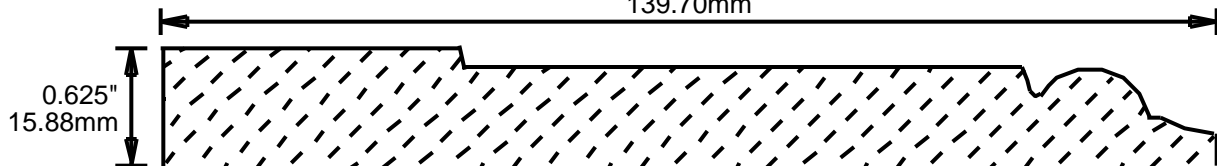

# WEINIG CASING AND BASE PATTERNS

CB5506202

5.5"

139.70mm

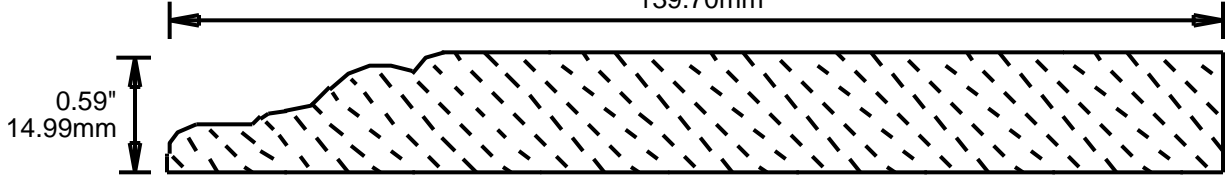

CB5506203

5.5"

139.70mm

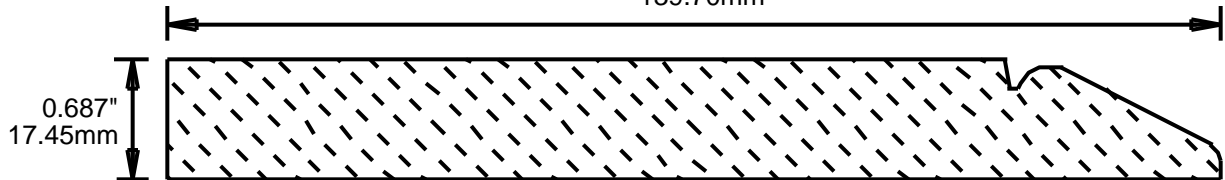

CB5506801

5.5"

139.70mm

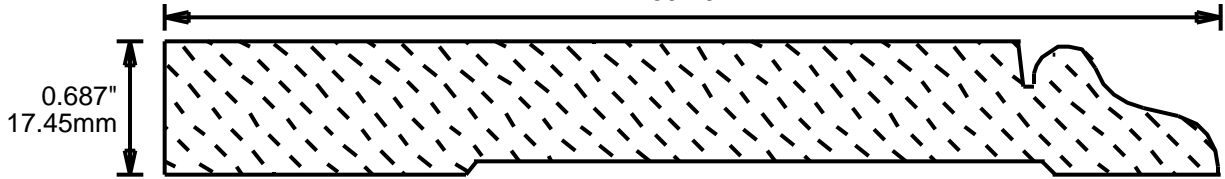

CB5506802

5.5"

139.70mm

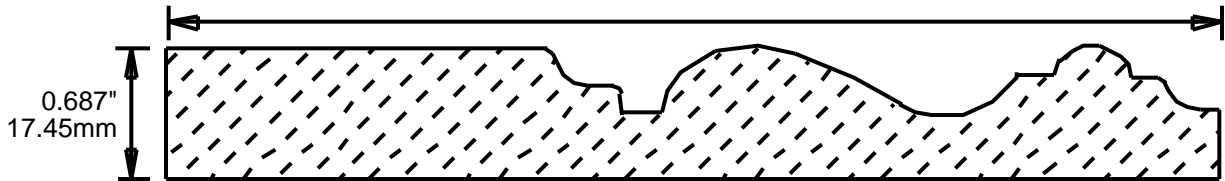

CB5507501

5.5"

139.70mm

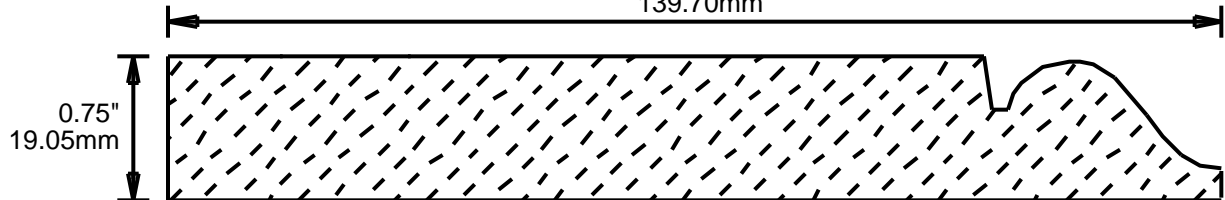

CB5507502

5.5"

139.70mm

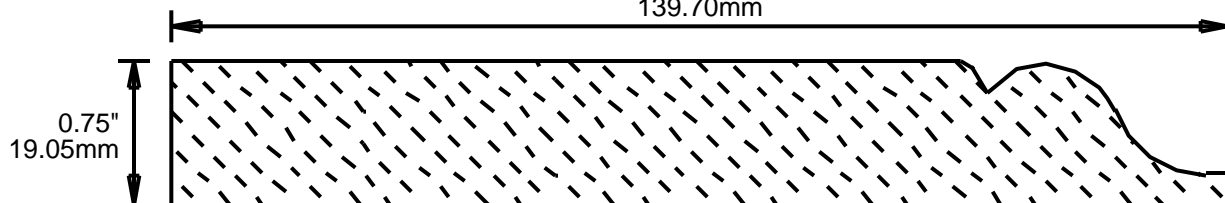

# WEINIG CASING AND BASE PATTERNS

CB5507503

5.5"

139.70mm

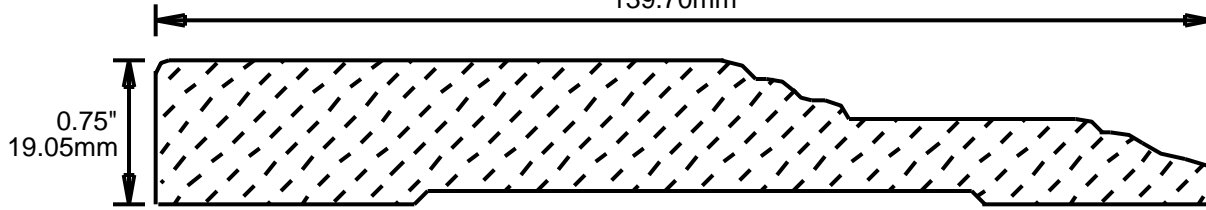

CB5507504

5.5"

139.70mm

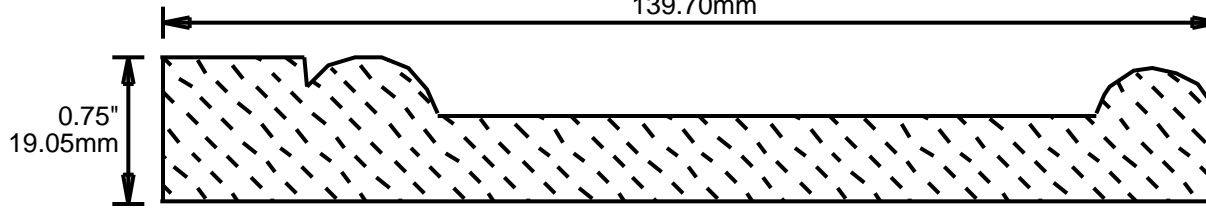

CB5507505

5.5"

139.70mm

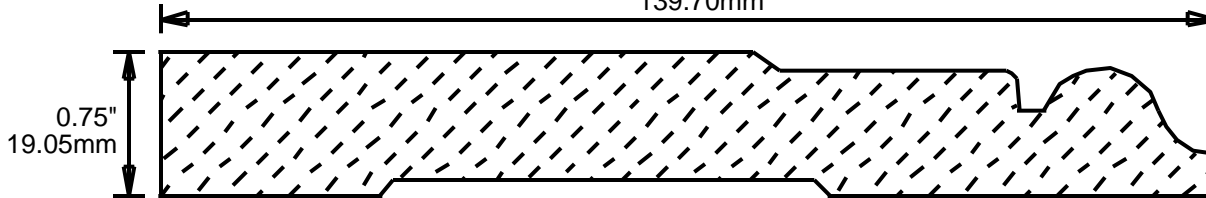

CB5507507

5.5"

139.70mm

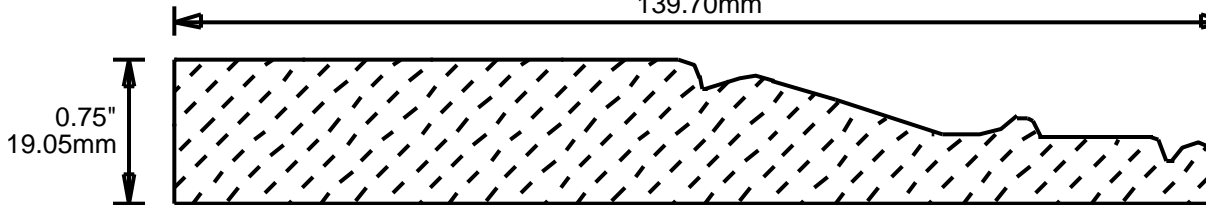

CB5507508

5.5"

139.70mm

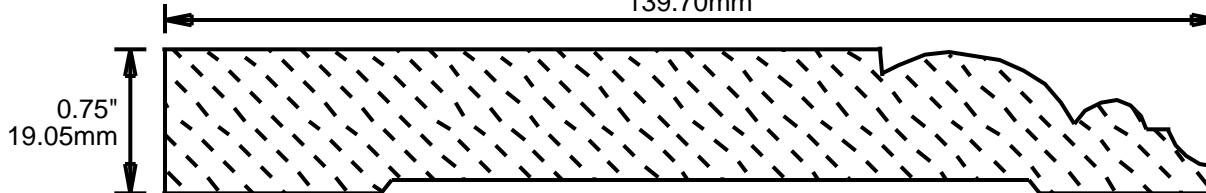

CB5507509

5.5"

139.70mm

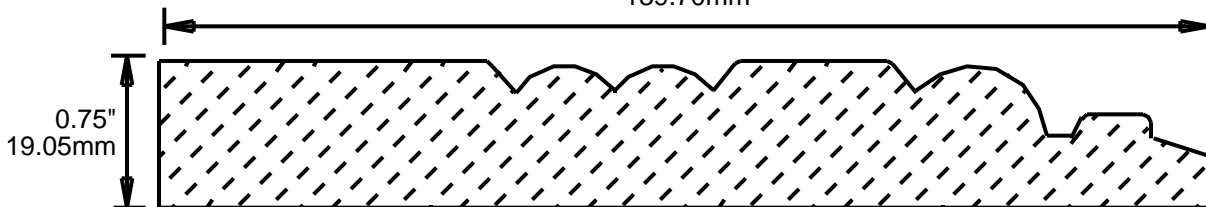

# WEINIG CASING AND BASE PATTERNS

CB5509301

5.5"

139.70mm

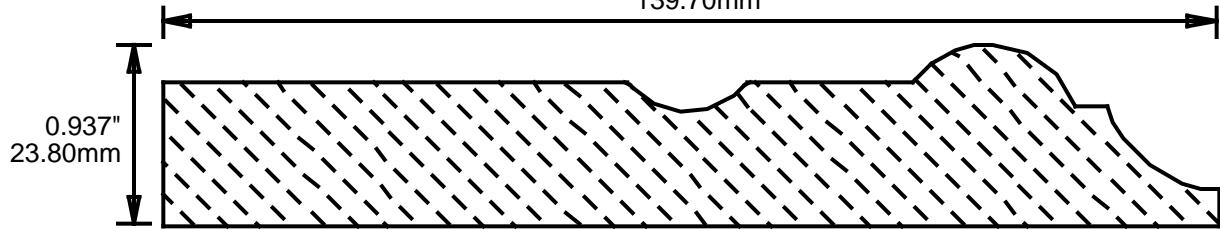

CB5621201

5.625"

142.88mm

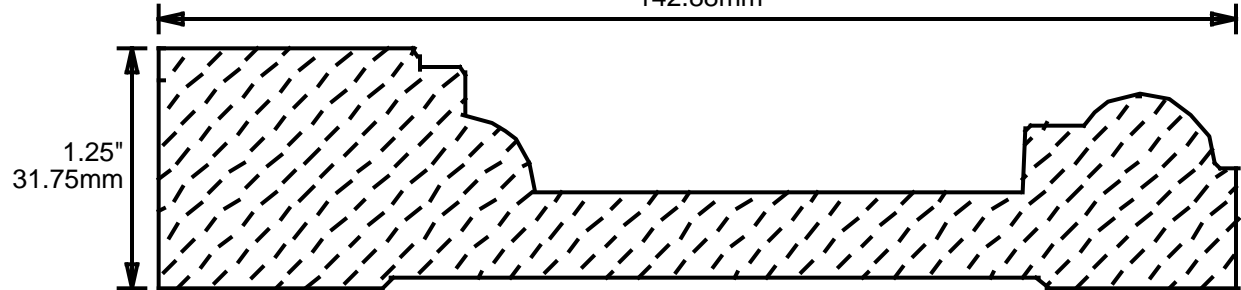

CB5626801

5.625"

142.88mm

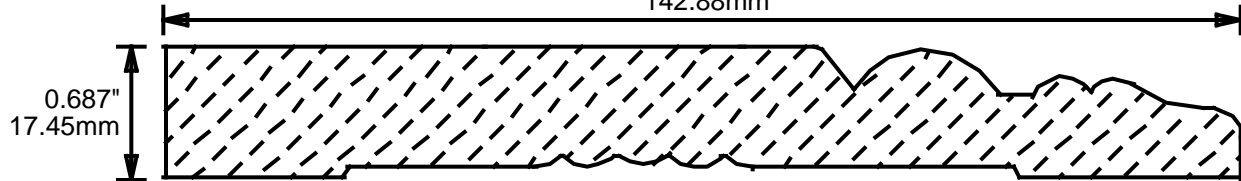

CB5751501

5.75"

146.05mm

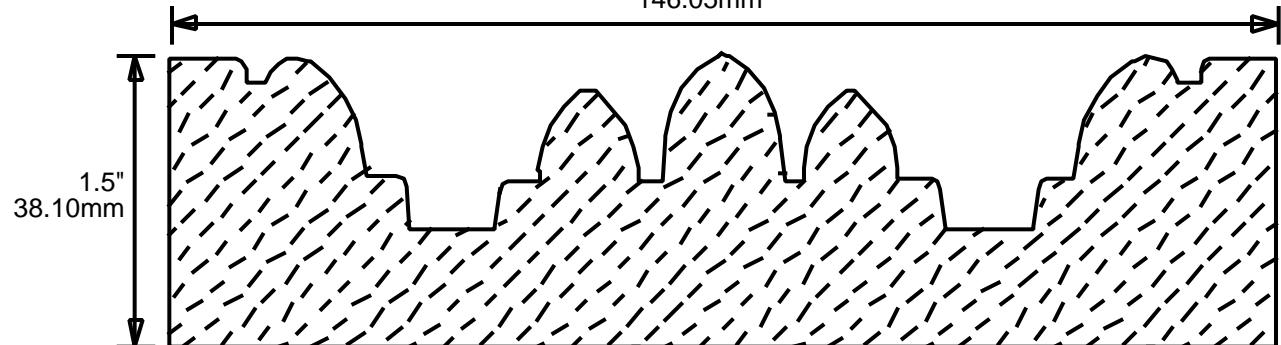

CB5871101

5.875"

149.23mm

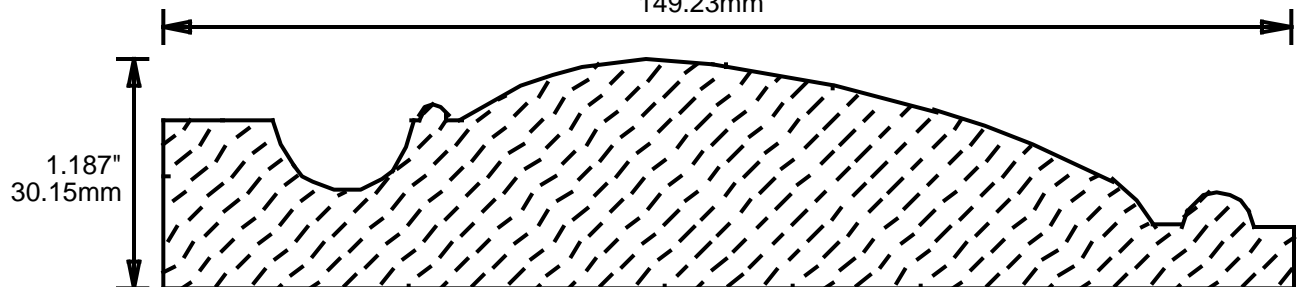

**PRINT  
THIS SECTION**

**RETURN TO  
Table of Contents**

# WEINIG CASING AND BASE PATTERNS

CB5877501

5.875"  
149.23mm

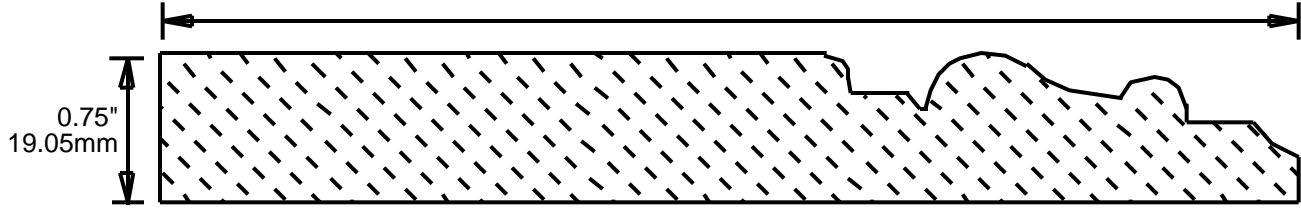

CB6001001

6"  
152.40mm

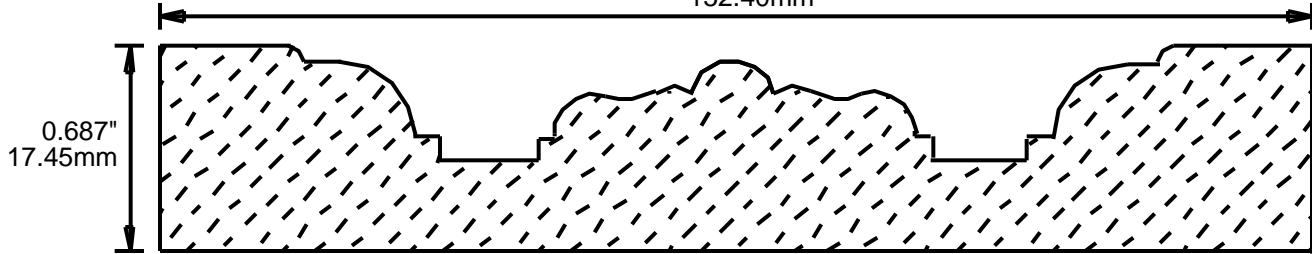

CB6001002

6"  
152.40mm

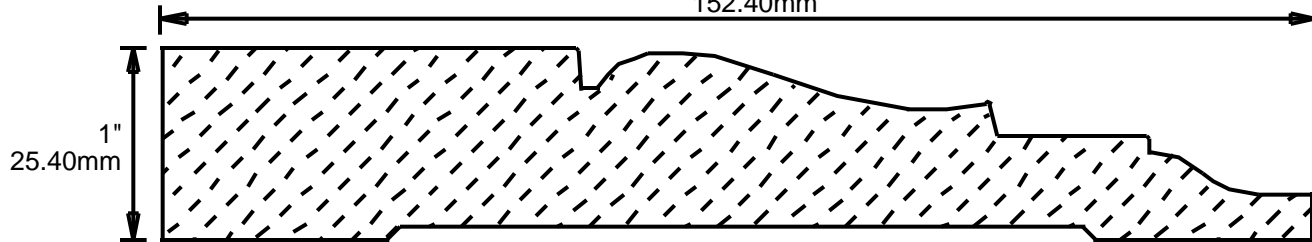

CB6001003

6"  
152.40mm

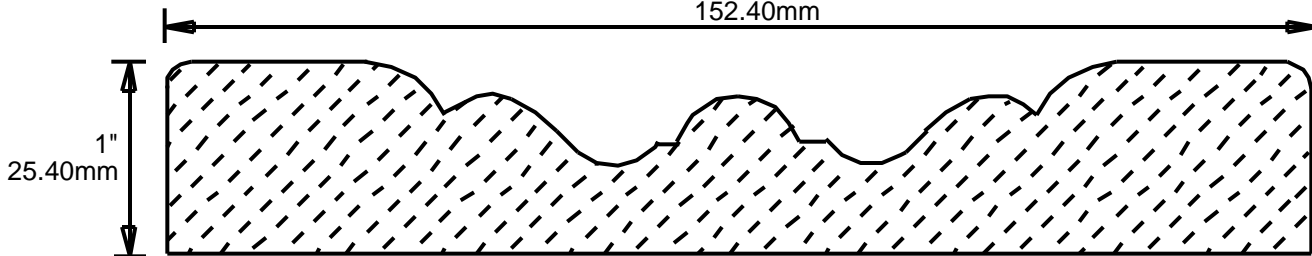

CB6001101

6"  
152.40mm

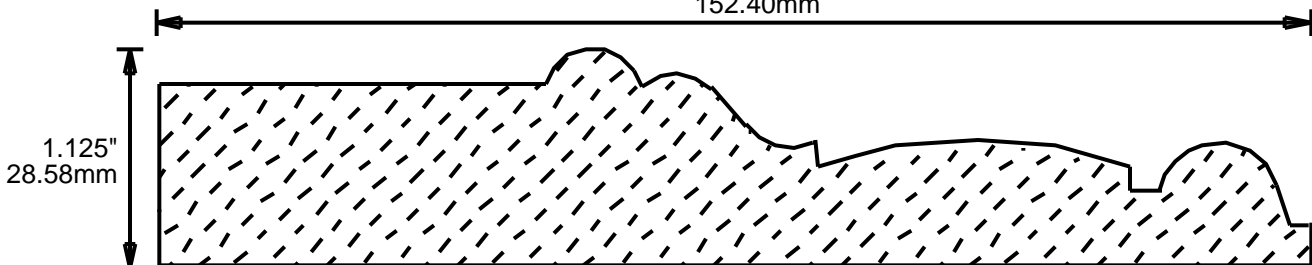

# WEINIG CASING AND BASE PATTERNS

CB6001500

6"

152.40mm

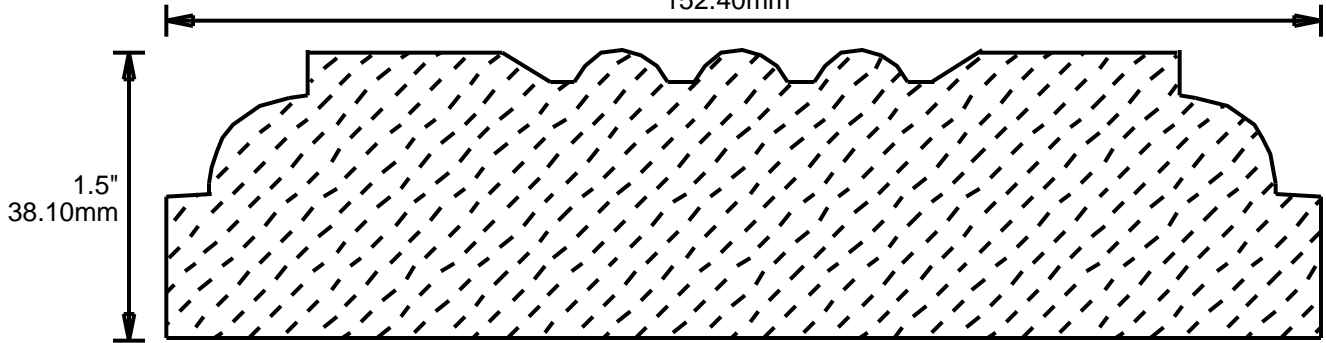

CB6006801

6"

152.40mm

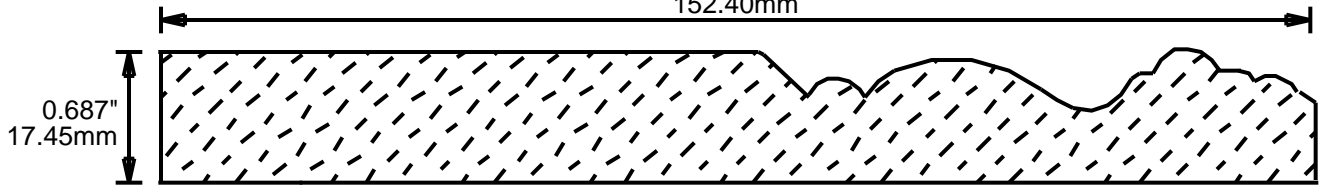

CB6006802

6"

152.40mm

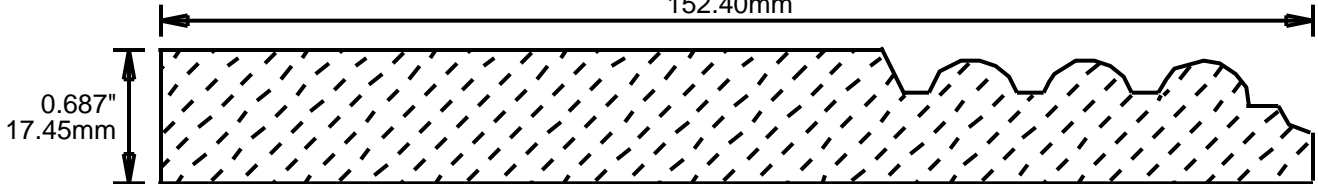

CB6007501

6"

152.40mm

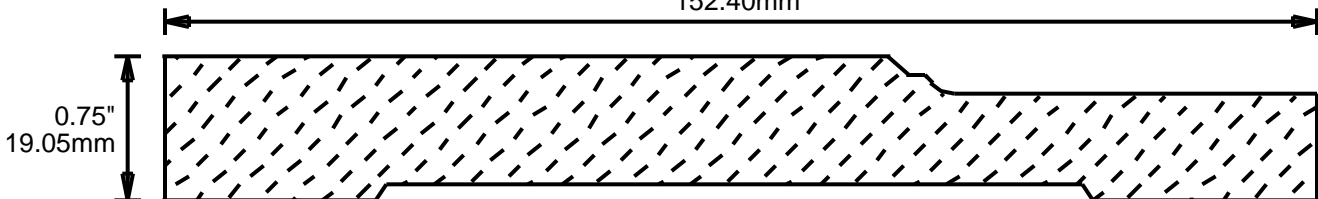

CB6007502

6"

152.40mm

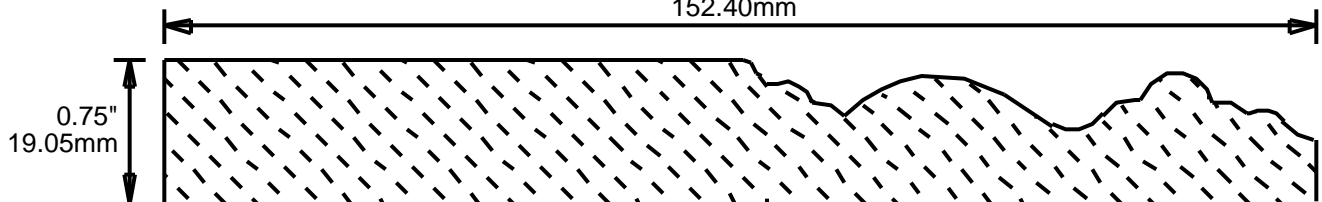

# WEINIG CASING AND BASE PATTERNS

CB6007504

6"  
152.40mm

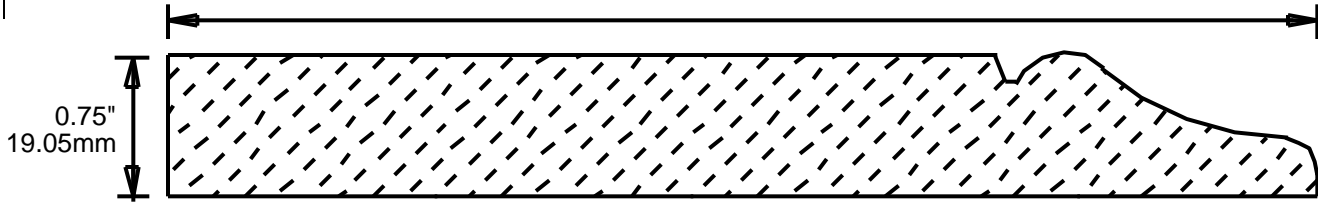

CB6007503

6"  
152.40mm

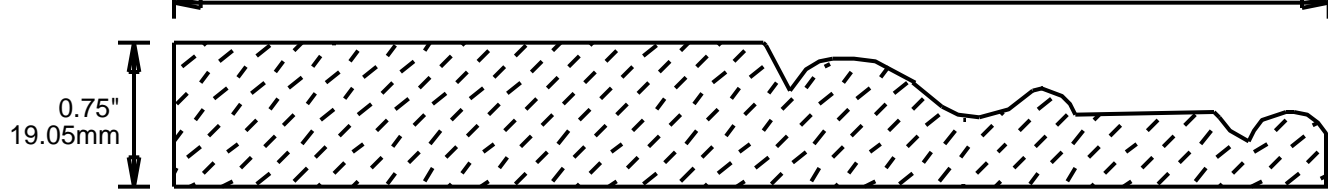

CB6007505

6"  
152.40mm

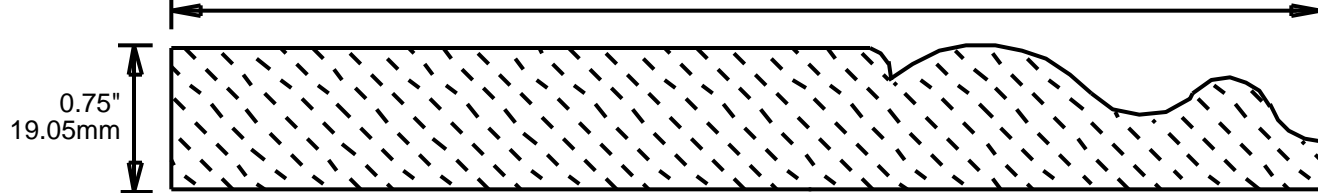

CB6251001

6.25"  
158.75mm

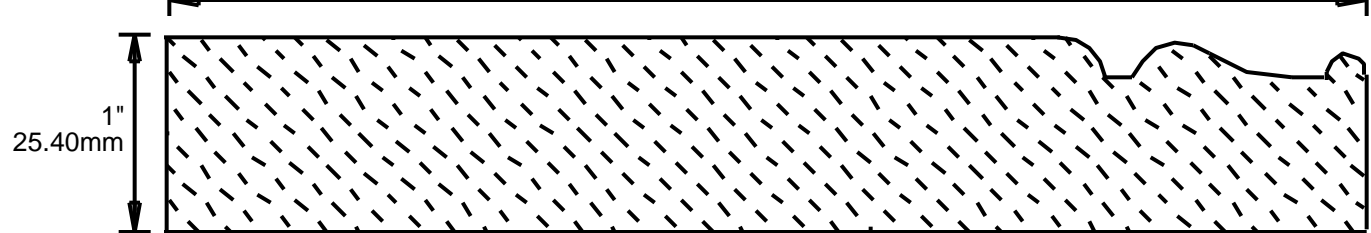

CB6506801

6.5"  
165.10mm

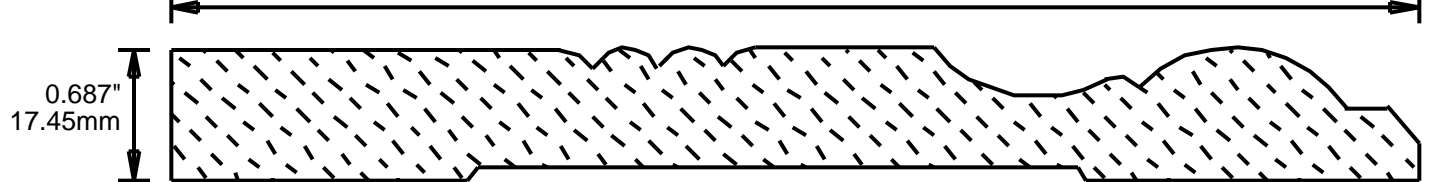

CB6507501

6.5"  
165.10mm

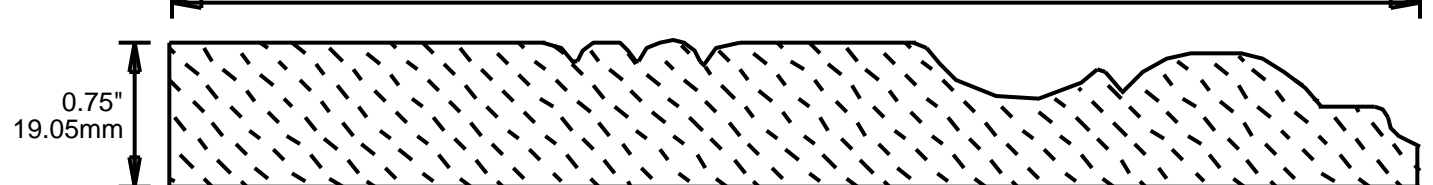



CB6757501

6.75"  
171.45mm

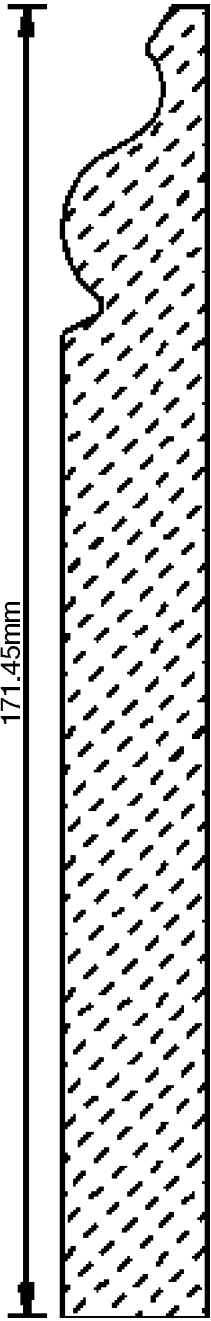

0.75"  
19.05mm

CB7007501

7"  
177.80mm

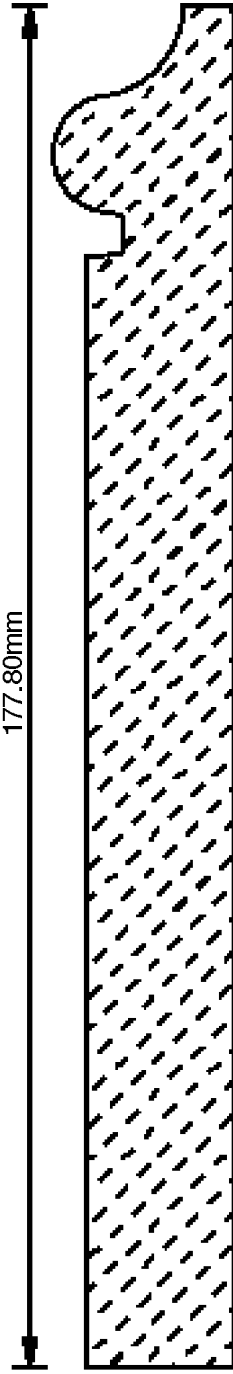

0.938"  
23.83mm

CB7377501

7.375"  
187.33mm

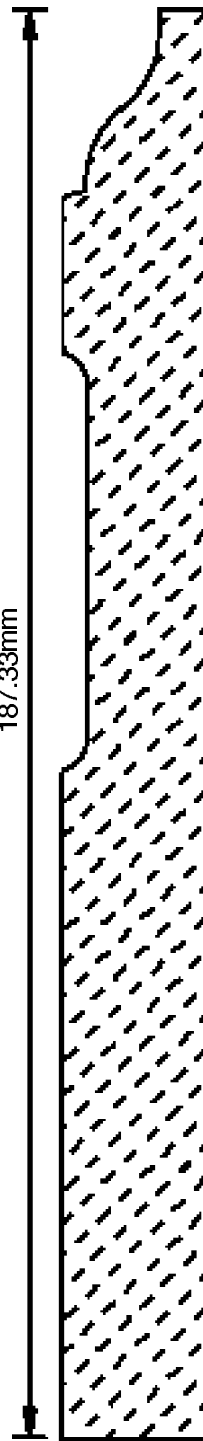

0.75"  
19.05mm

CB7377502

7.375"  
187.33mm

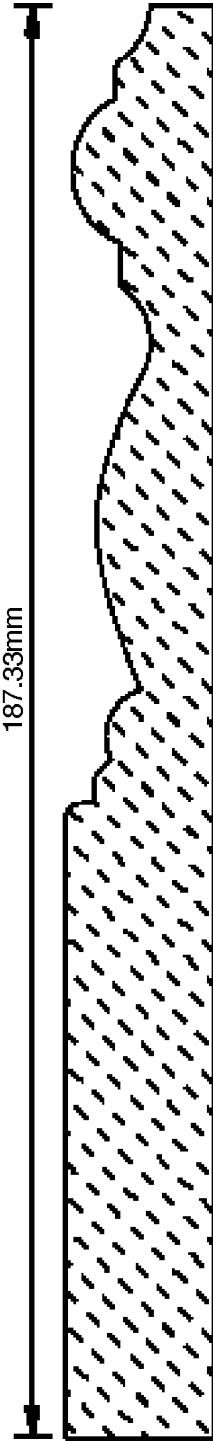

0.75"  
19.05mm

# WEINIG CASING AND BASE PATTERNS

CB7567501

7.562"  
192.07mm

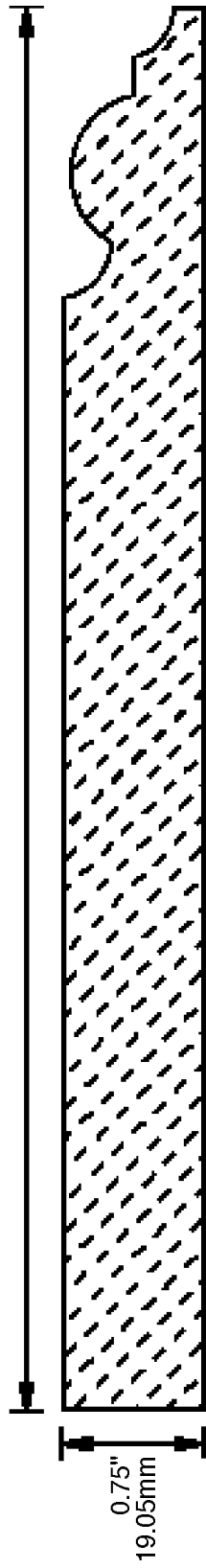

CB8007501

8"  
203.20mm

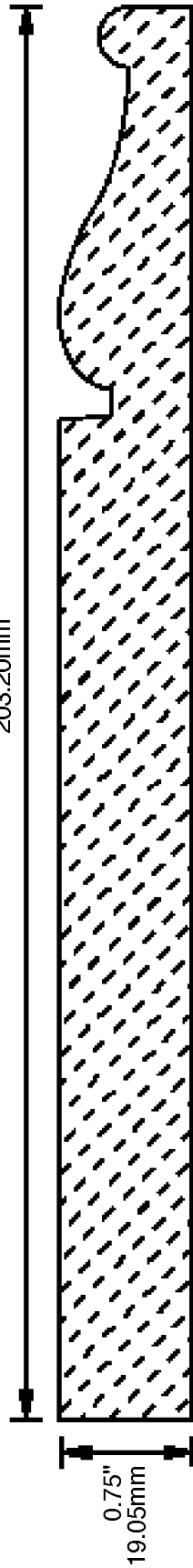

CB8508101

8.5"  
215.90mm

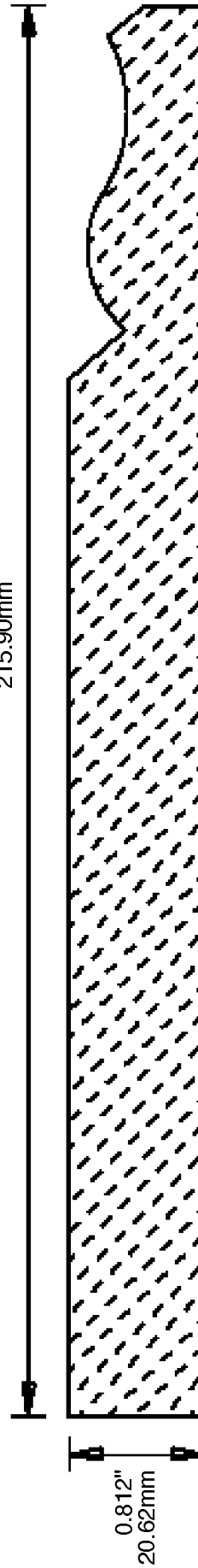

# WEINIG CASING AND BASE PATTERNS

CB8757501  
8.5"

215.90mm

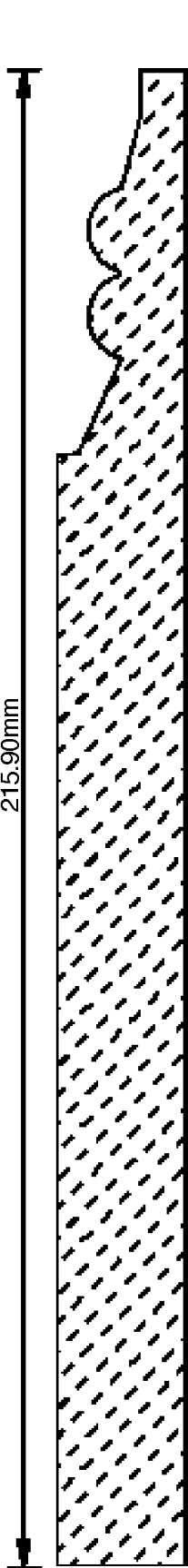

0.812"  
20.62mm

CB8871601  
8.875"

225.43mm

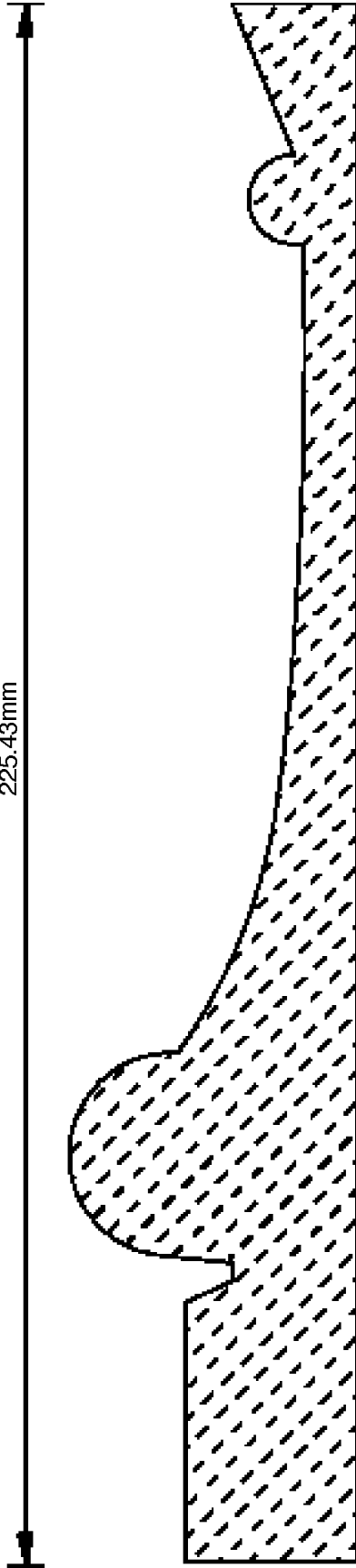

1.625"  
41.28mm

CB9001001  
9"

228.60mm

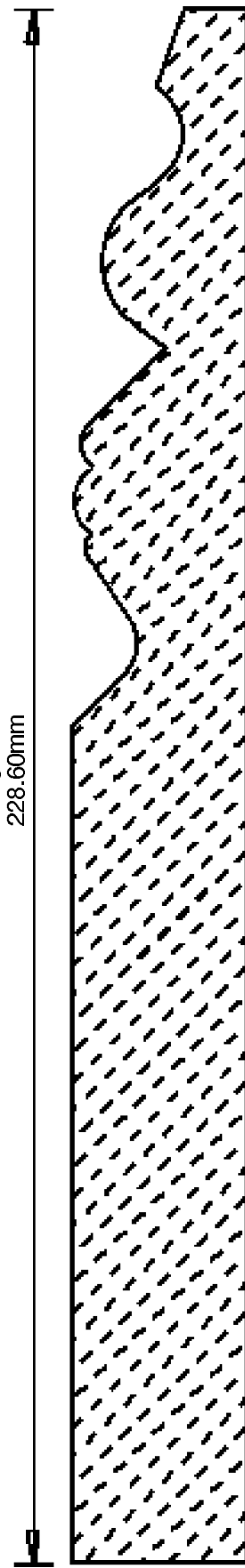

1"  
25.40mm

**PRINT  
THIS SECTION**

**RETURN TO  
Table of Contents**

# WEINIG CASING AND BASE PATTERNS FLUTED

FB22551  
2.25"  
57.15mm

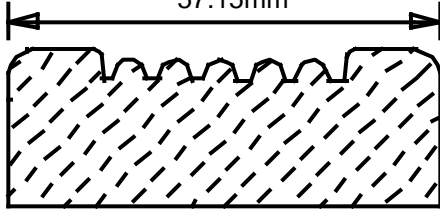

FB22552  
2.25"  
57.15mm

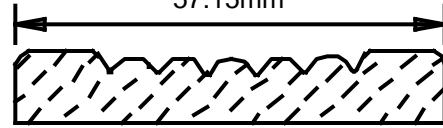

FB22571  
2.25"  
57.15mm

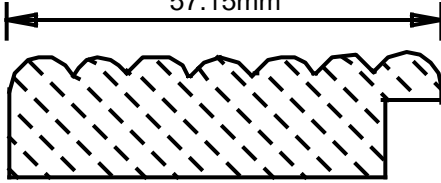

FB25071  
2.5"  
63.50mm

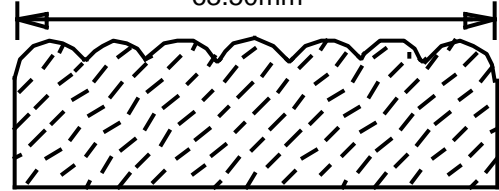

FB26241  
2.625"  
66.68mm

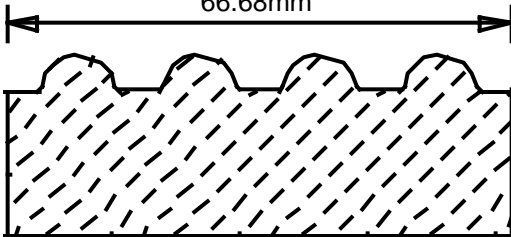

FB27591  
2.75"  
69.85mm

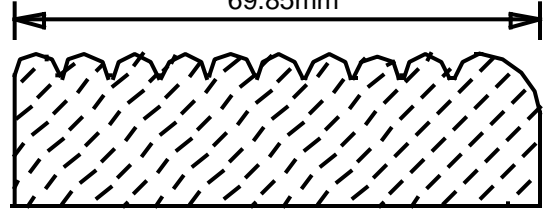

FB30041  
3"  
76.20mm

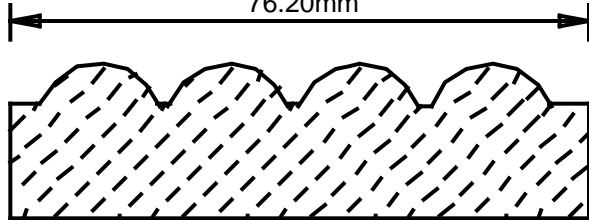

FB30051  
3"  
76.20mm

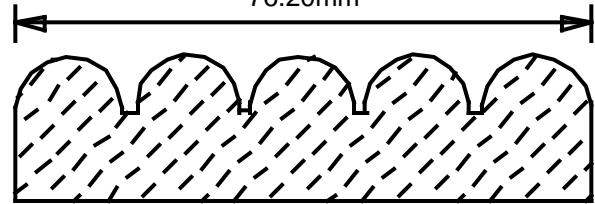

FB31231  
3.125"  
79.38mm

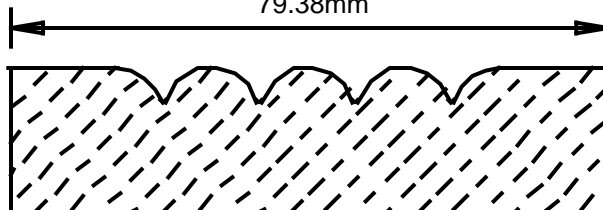

FB32531  
3.25"  
82.55mm

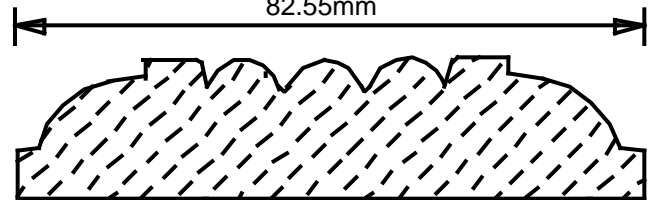

# WEINIG CASING AND BASE PATTERNS

## FLUTED

FB32541  
3.25"  
82.55mm

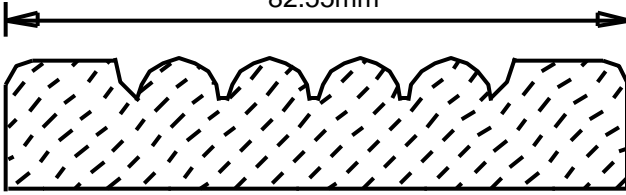

FB32741  
3.274"  
83.16mm

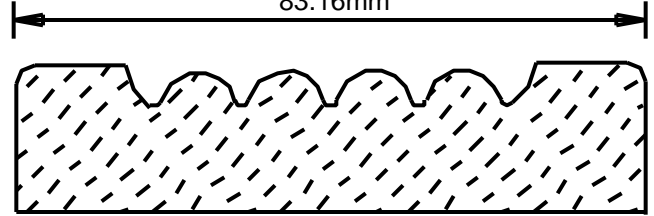

FB33141  
3.312"  
84.12mm

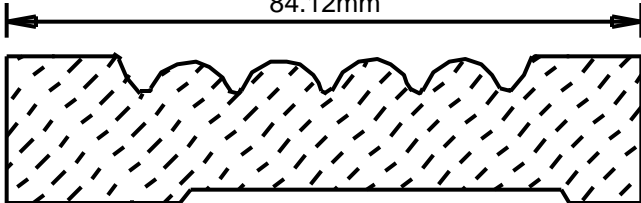

FB35041  
3.5"  
88.90mm

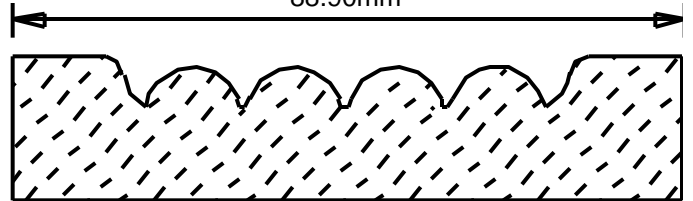

FB35042  
3.5"  
88.90mm

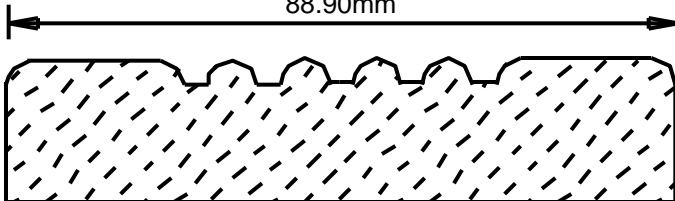

FB35043  
3.5"  
88.90mm

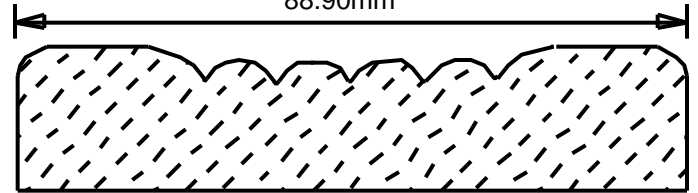

FB40061  
4"  
101.60mm

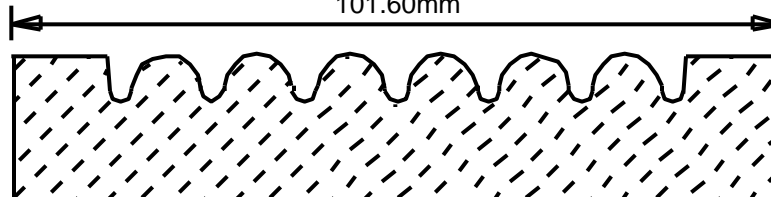

FB45071  
4.5"  
114.30mm

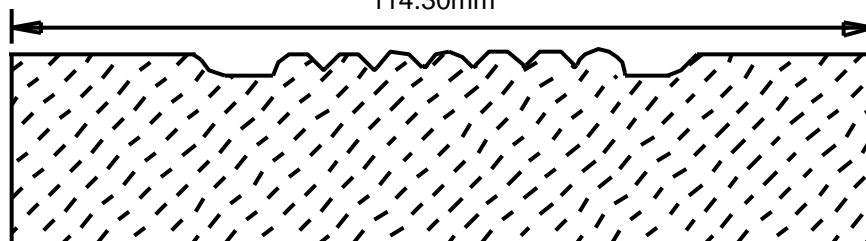

# WEINIG CASING AND BASE PATTERNS FLUTED

FB45661  
4.562"  
115.87mm

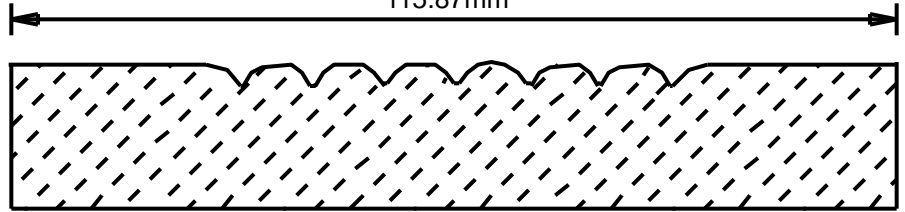

FB47571  
4.75"  
120.65mm

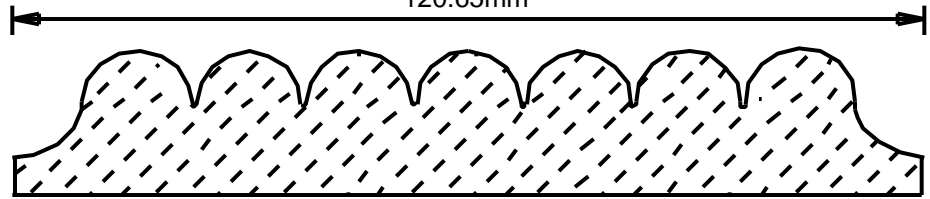

FB47572  
4.75"  
120.65mm

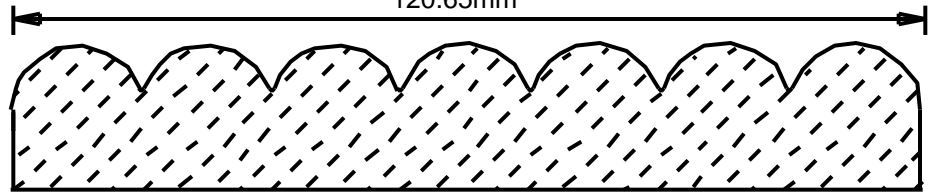

FB48751  
4.875"  
123.83mm

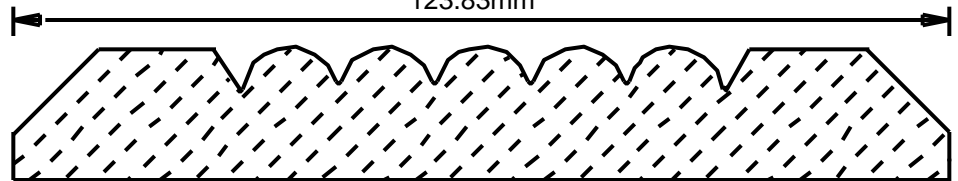

FB50041  
5"  
127.00mm

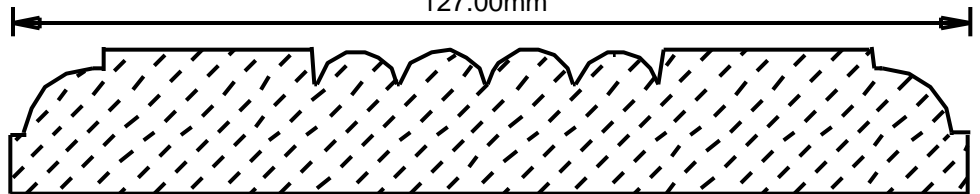

FB55071  
5.5"  
139.70mm

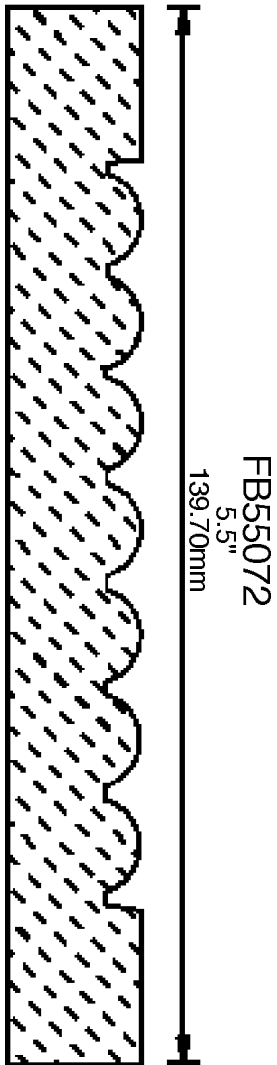
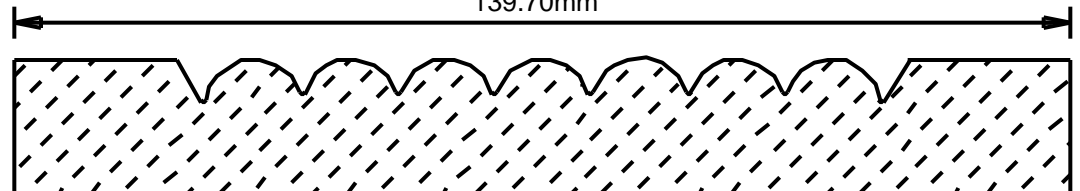

# WEINIG CASING AND BASE PATTERNS FLUTED

FB60041

6"

154.40mm

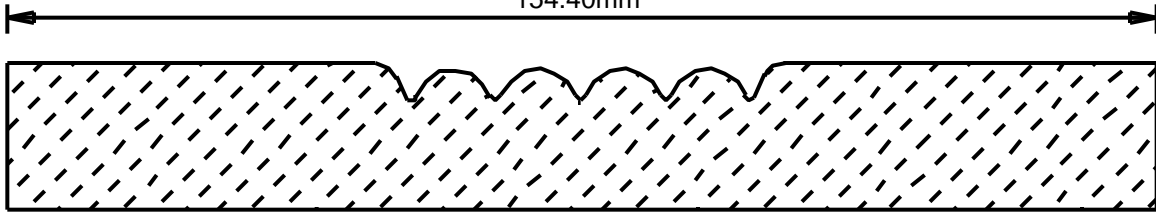

FB62591

6.25"

158.75mm

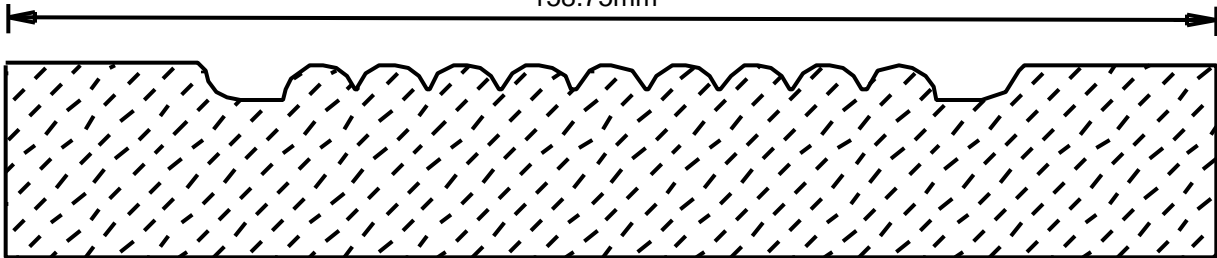

FB70071

7"

177.80mm

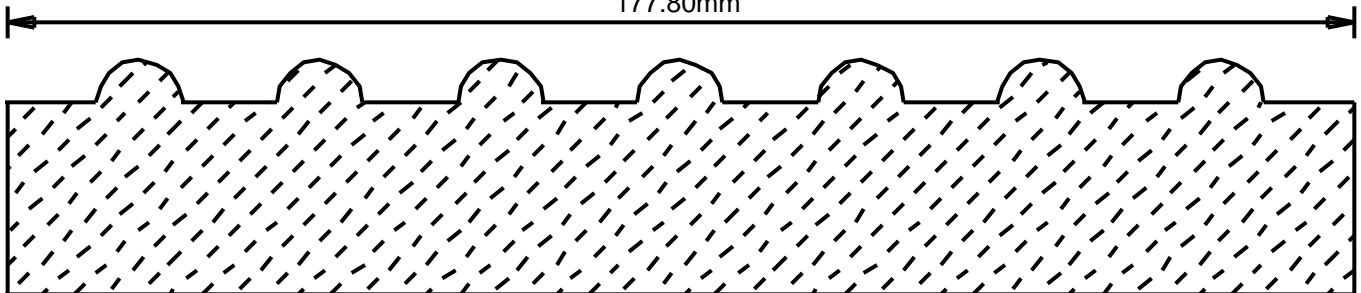

FC15031

1.5"

38.10mm

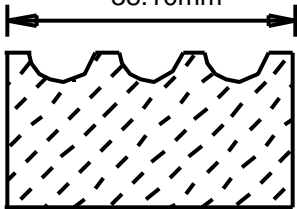

FC15041

1.5"

38.10mm

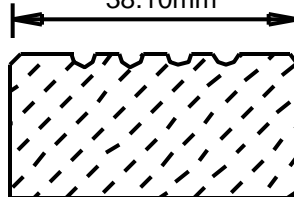

FC22531

2.25"

57.15mm

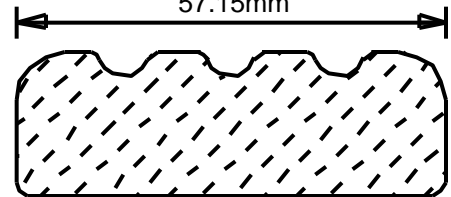

FC22532

2.25"

57.15mm

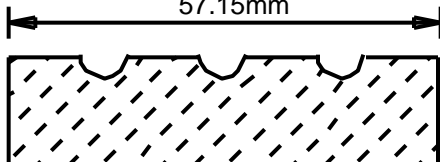

FC22541

2.25"

57.15mm

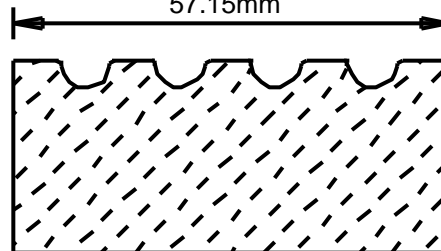

# WEINIG CASING AND BASE PATTERNS FLUTED

FC30031

3"

76.20mm

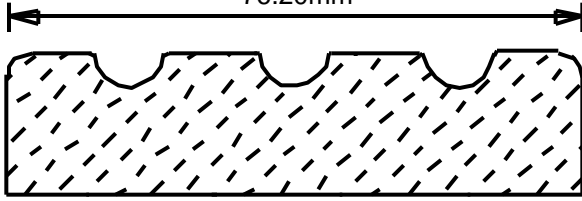

FC30032

3"

76.20mm



FC32531

3.25"

82.55mm

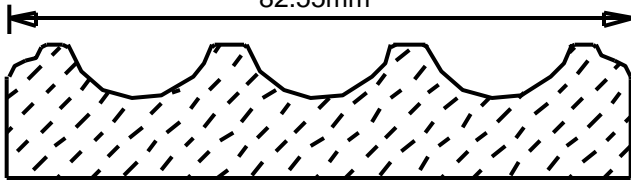

FC32532

3.25"

82.55mm

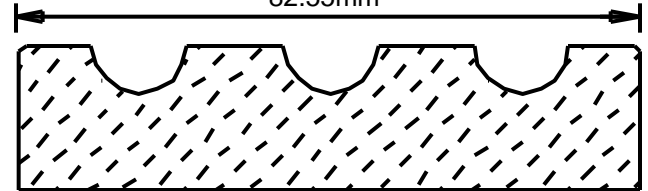

FC32541

3.25"

82.55mm

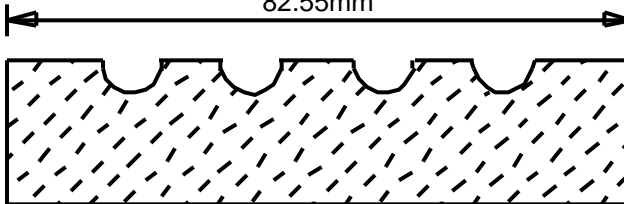

FC32542

3.25"

82.55mm

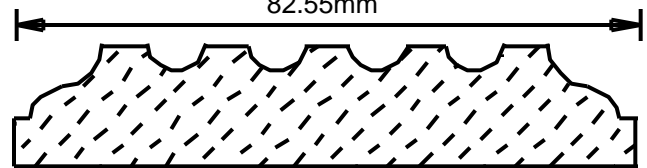

FC33731

3.375"

85.73mm

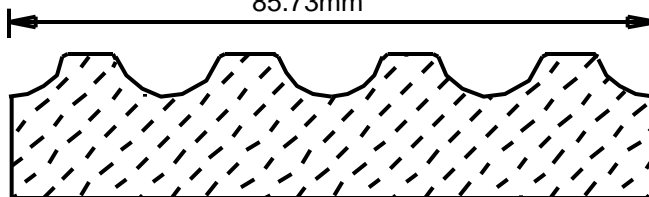

FC34331

3.438"

87.33mm

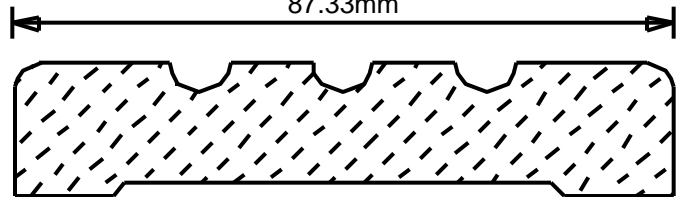

FC34351

3.437"

87.30mm

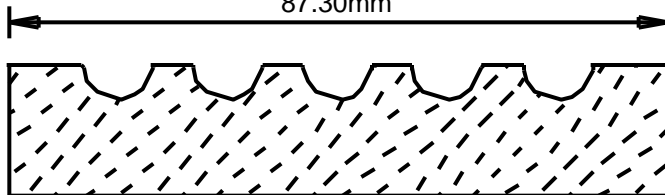

FC35031

3.5"

88.90mm

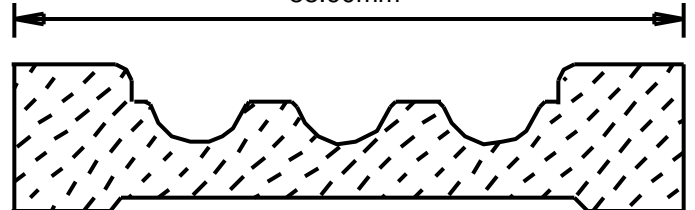

FC35032

3.5"

88.90mm

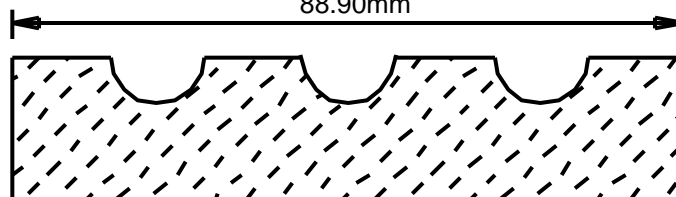

**PRINT  
THIS SECTION**

**RETURN TO  
Table of Contents**



# WEINIG CASING AND BASE PATTERNS

## FLUTED

FC35041  
3.5"  
88.90mm

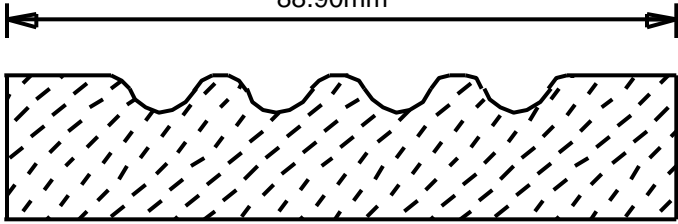

FC35042  
3.5"  
88.90mm

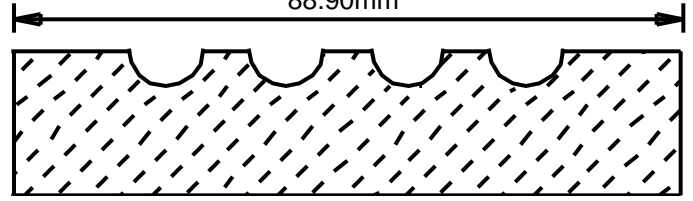

FC35043  
3.5"  
88.90mm

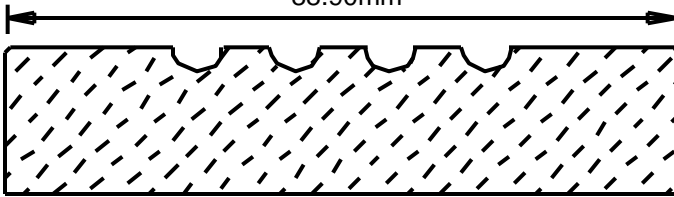

FC35051  
3.5"  
88.90mm

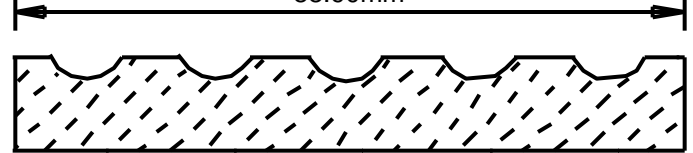

FC35621  
3.562"  
90.47mm

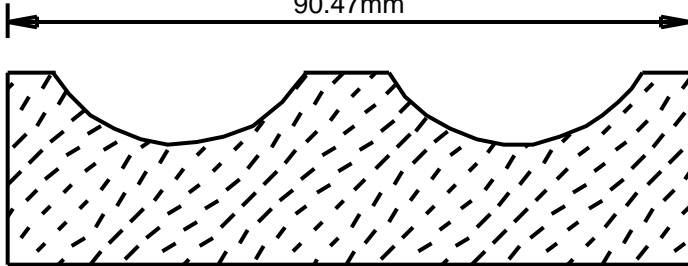

FC36231  
3.625"  
92.08mm

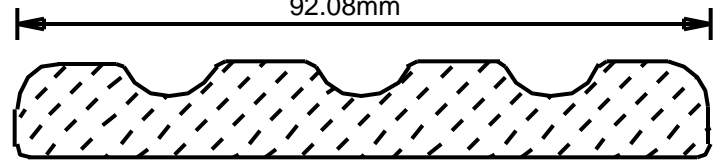

FC36241  
3.625"  
92.08mm

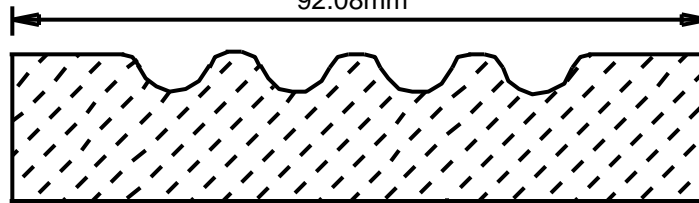

FC42541  
4.25"  
107.95mm

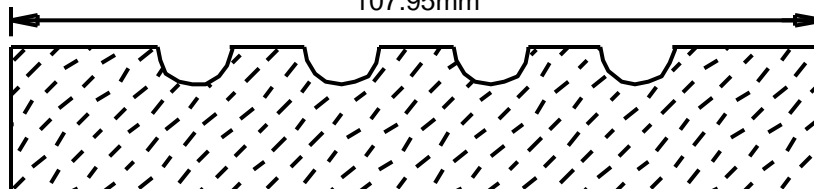

FC42551  
4.25"  
107.95mm

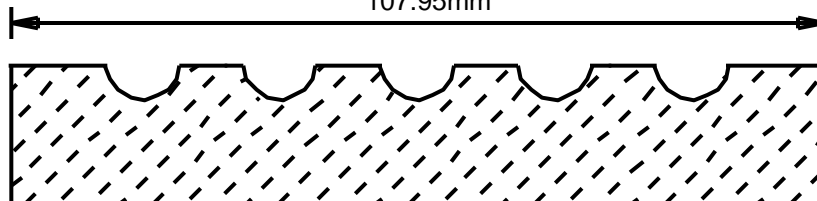

# WEINIG CASING AND BASE PATTERNS FLUTED

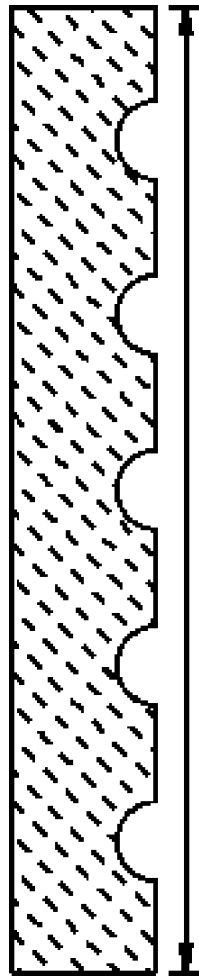

FC50051  
5"  
127.00mm

FC45031  
4.5"  
114.30mm

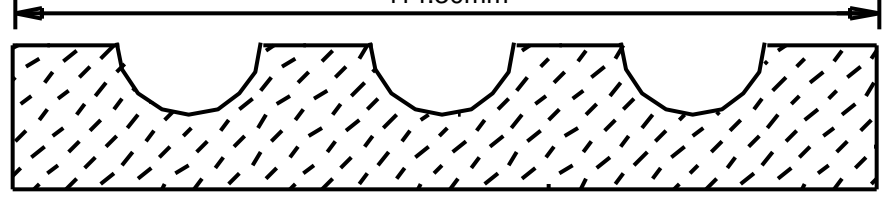

FC45041  
4.5"  
114.30mm

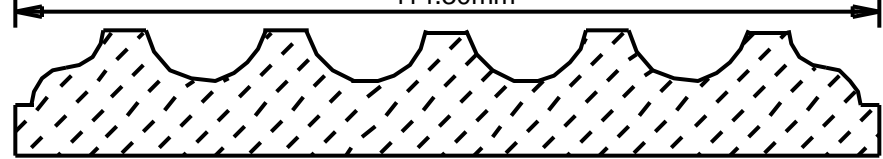

FC47541  
4.75"  
120.65mm

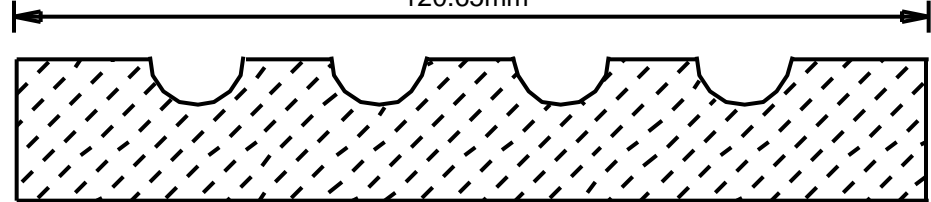

FC50041  
5"  
127.00mm

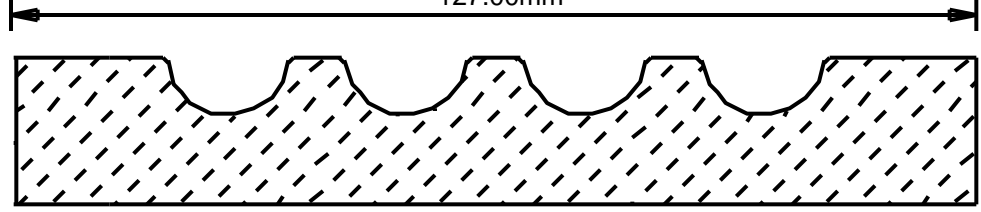

FC50042  
5"  
127.00mm

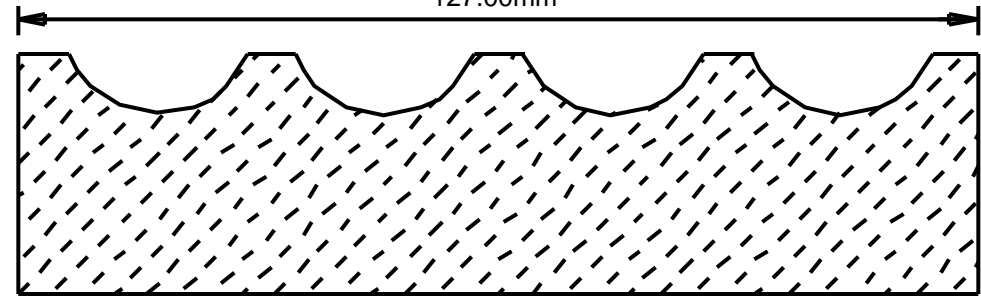

**PRINT  
THIS SECTION**

**RETURN TO  
Table of Contents**

# WEINIG CASING AND BASE PATTERNS

## FLUTED

FC51261  
5.125"  
130.18mm

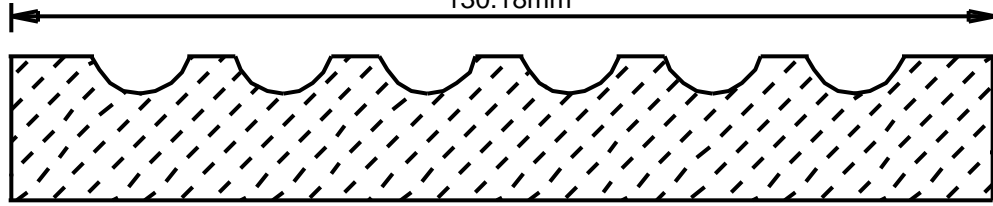

FC52541  
5.25"  
133.35mm

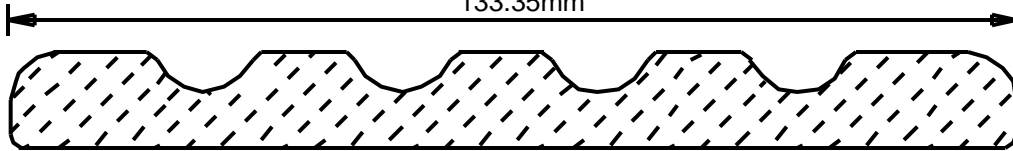

FC52542  
5.25"  
133.35mm

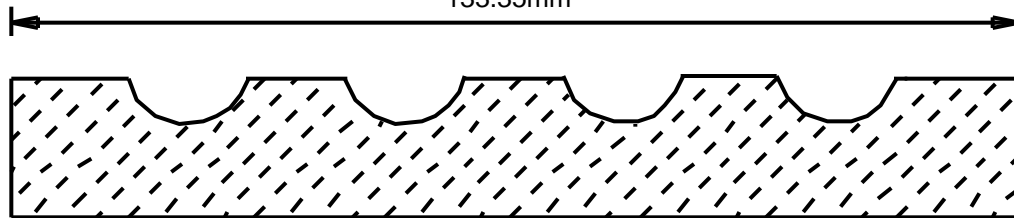

FC52543  
5.25"  
133.35mm

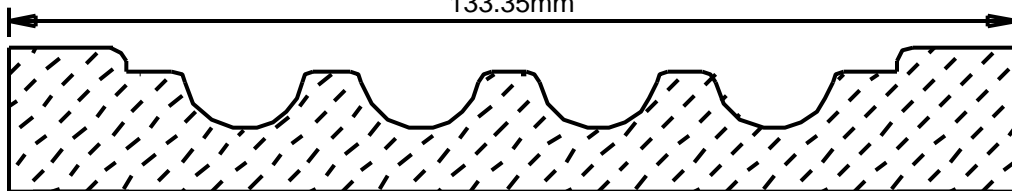

FC52561  
5.25"  
133.35mm

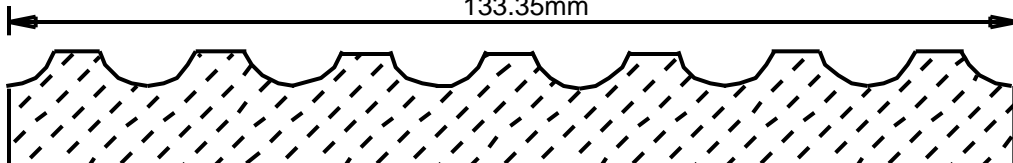

**WEINIG CASING AND BASE PATTERNS  
FLUTED**

FC55051  
5.5"  
139.70mm

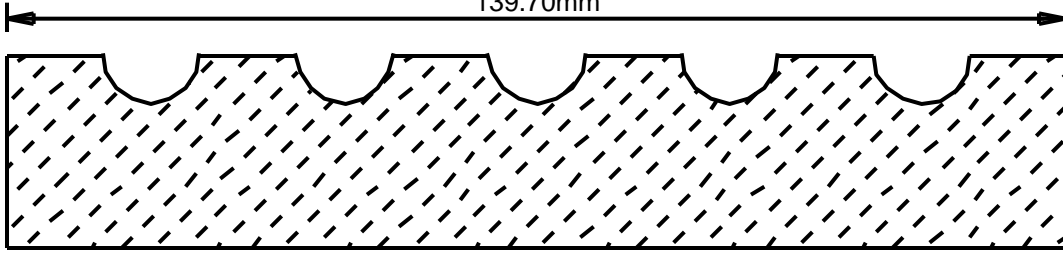

FC55052  
5.5"  
139.70mm

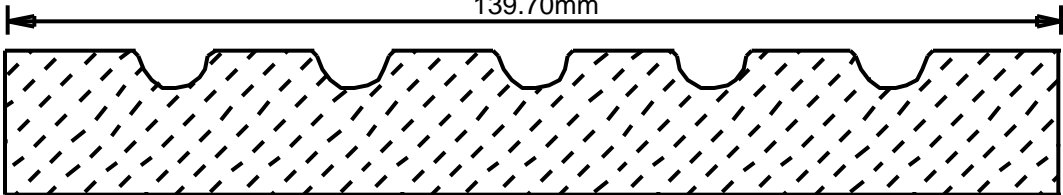

FC55061  
5.5"  
139.70mm

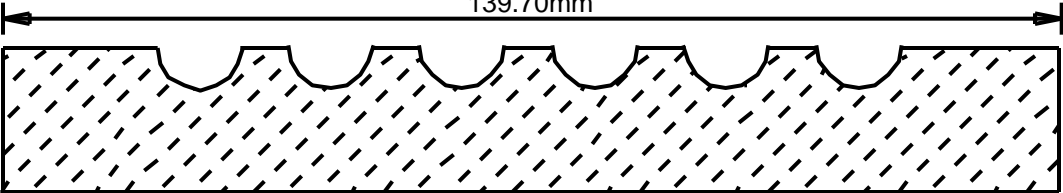

FC55081  
5.5"  
139.70mm

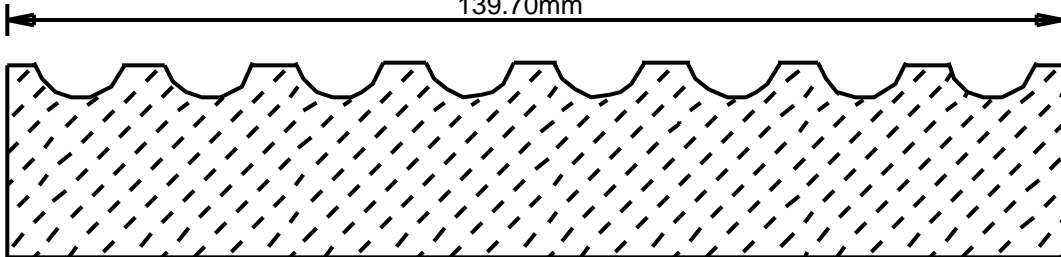

FC62561  
6.25"  
158.75mm

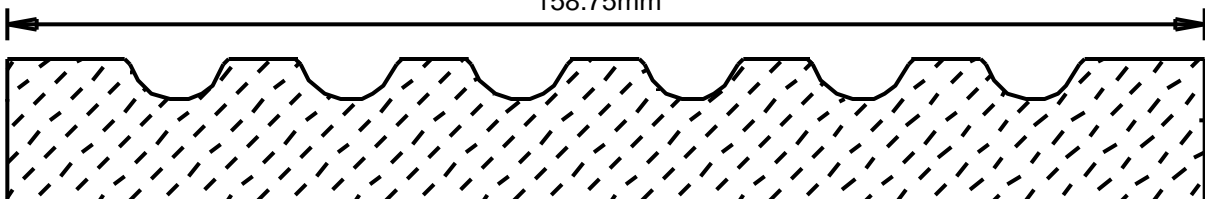

**WEINIG CASING AND BASE PATTERNS  
FLUTED**

FC65051  
6.5"  
165.10mm

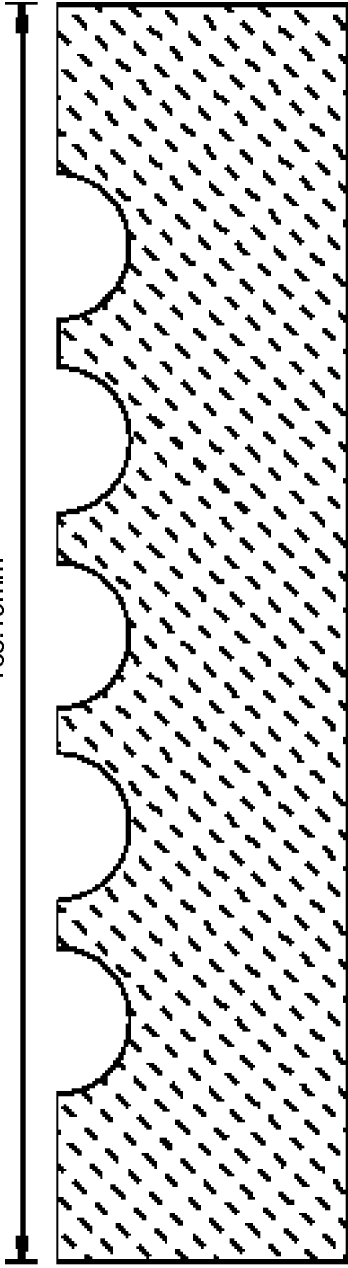

FC80051  
8"  
203.20mm

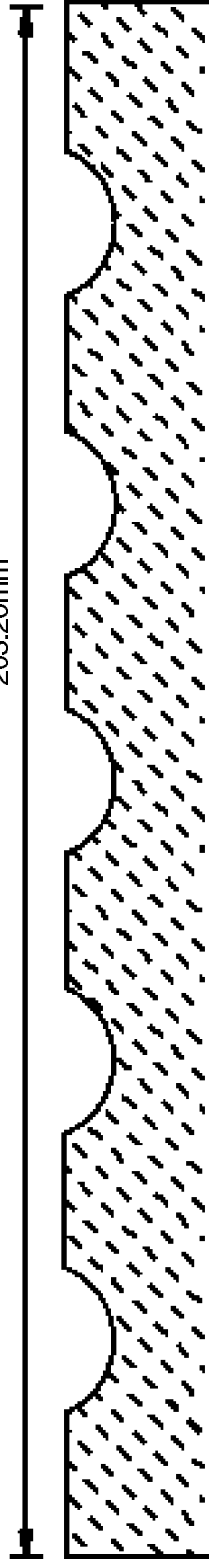

FC80052  
8"  
203.20mm

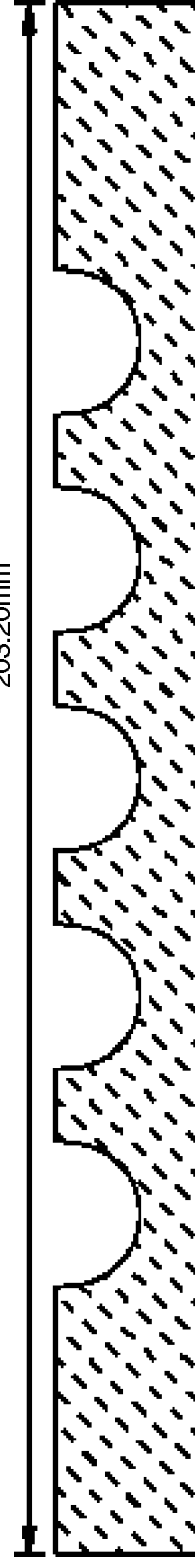

# WEINIG CASING AND BASE PATTERNS FLUTED

FD31501  
3.156"  
80.16mm

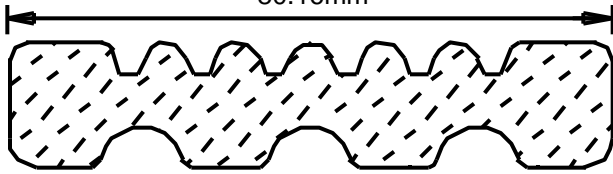

FD32501  
3.25"  
82.55mm



FD32502  
3.25"  
82.55mm

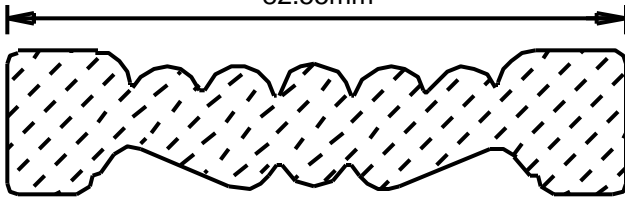

FD32503  
3.25"  
82.55mm

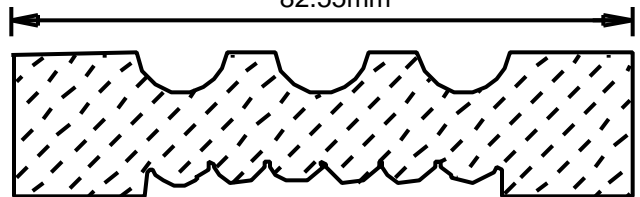

FD32504  
3.25"  
82.55mm

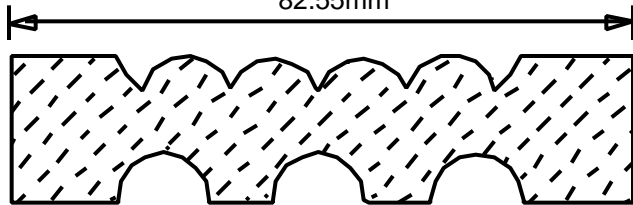

FD32505  
3.25"  
82.55mm

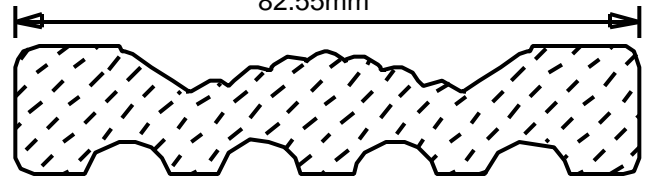

FD33701  
3.375"  
85.73mm



# WEINIG CASING AND BASE PATTERNS

## FLUTED

FD34301  
3.437"  
87.30mm

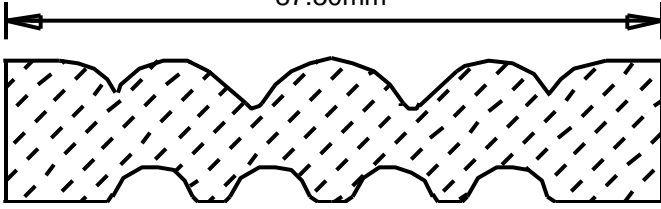

FD35001  
3.5"  
88.90mm

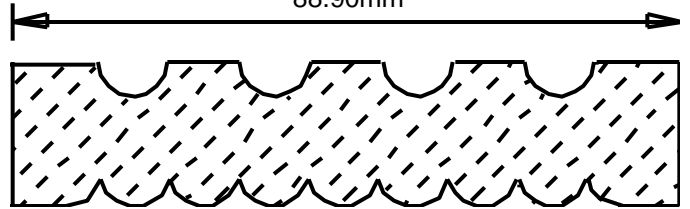

FD35002  
3.5"  
88.90mm

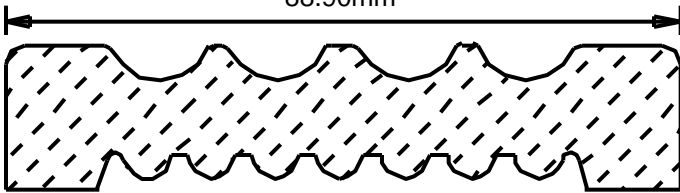

FD35003  
3.5"  
88.90mm

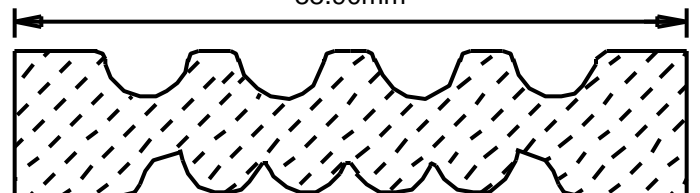

FD42501  
4.25"  
107.95mm

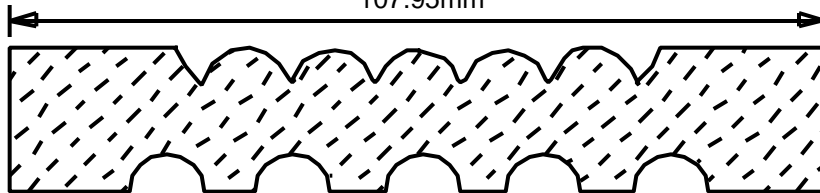

Templates for the rail moulding patterns shown in this book are available through Weinig Custom Grinding Service.

In addition to these stock templates, Weinig Custom Grinding Service also will make custom-profile templates specifically for your needs. Templates can be made using other CAD drawings, a wood sample, a tracing, or only an idea.

## RAIL MOULDING PATTERNS

Example: HR P 12 23 01

HR	Hand Rail
	BR Bar Rail
	CH Chair Rail
P	Profiled Hand Rail
	R Radiused-only Hand Rail
12	Thickness, as first 2 decimals
23	Width, as first 2 decimals
01	Profile Number

[CLICK HERE TO SEE BAR RAILS](#)

[CLICK HERE TO SEE CHAIR RAILS](#)

[CLICK HERE TO SEE PROFILED HAND RAILS](#)

[CLICK HERE TO SEE RADIUS-ONLY HAND RAILS](#)



# WEINIG RAIL MOULDING PATTERNS

## BAR RAILS

Templates for the rail moulding patterns shown in this book are available through Weinig Custom Grinding Service.

In addition to these stock templates, Weinig Custom Grinding Service also will make custom-profile templates specifically for your needs. Templates can be made using other CAD drawings, a wood sample, a tracing, or only an idea.

### RAIL MOULDING PATTERNS

Example: HR P 12 23 01

HR	Hand Rail
BR	Bar Rail
CH	Chair Rail
P	Profiled Hand Rail
R	Radiused-only Hand Rail
12	Thickness, as first 2 decimals
23	Width, as first 2 decimals
01	Profile Number

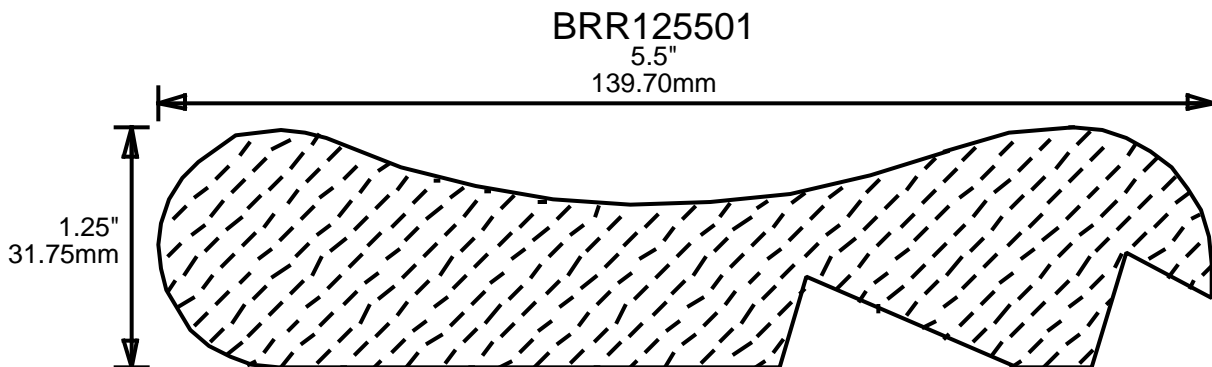
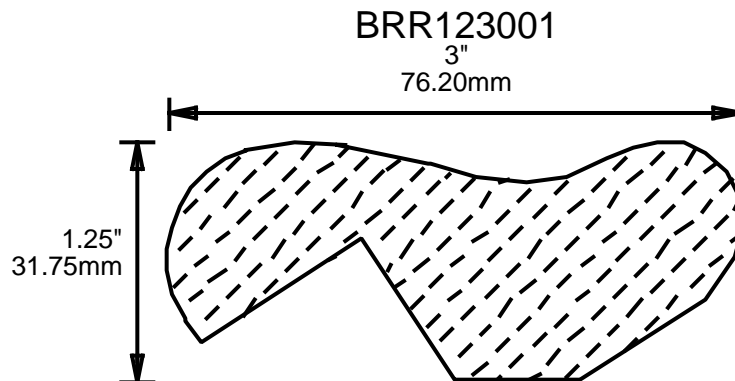

# WEINIG RAIL MOULDING PATTERNS

## BAR RAILS

BRR134301

4.375"  
111.125mm

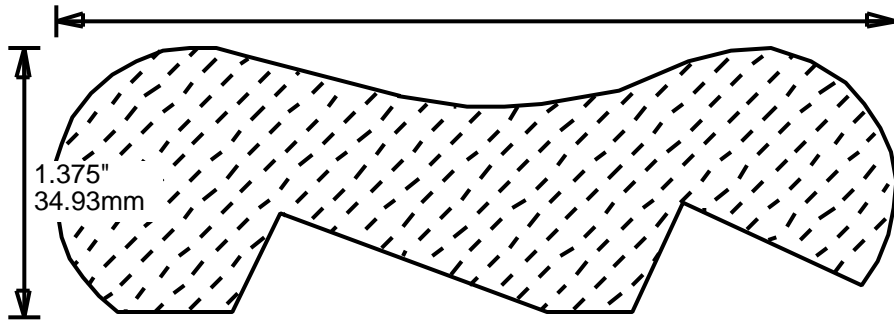

BRR156501

6.5"  
165.10mm

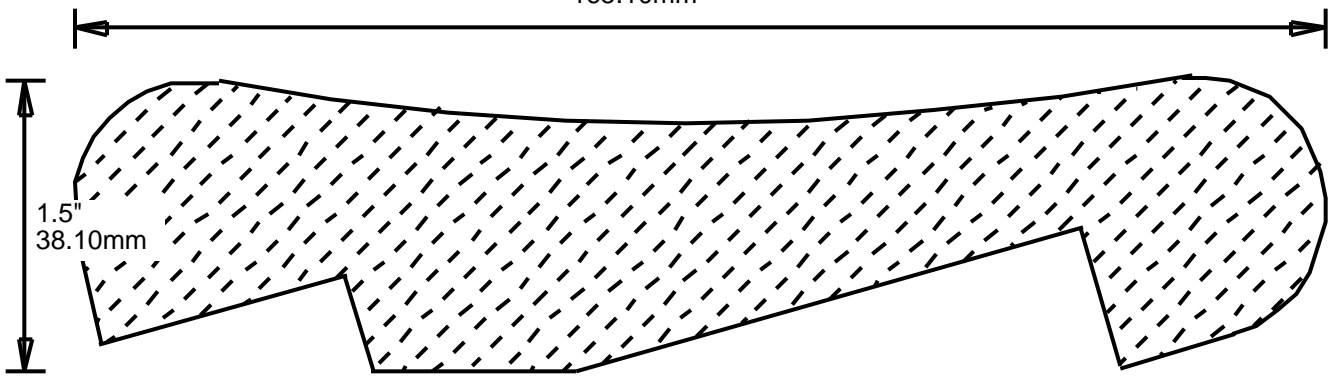

BRR156601

6.625"  
168.28mm

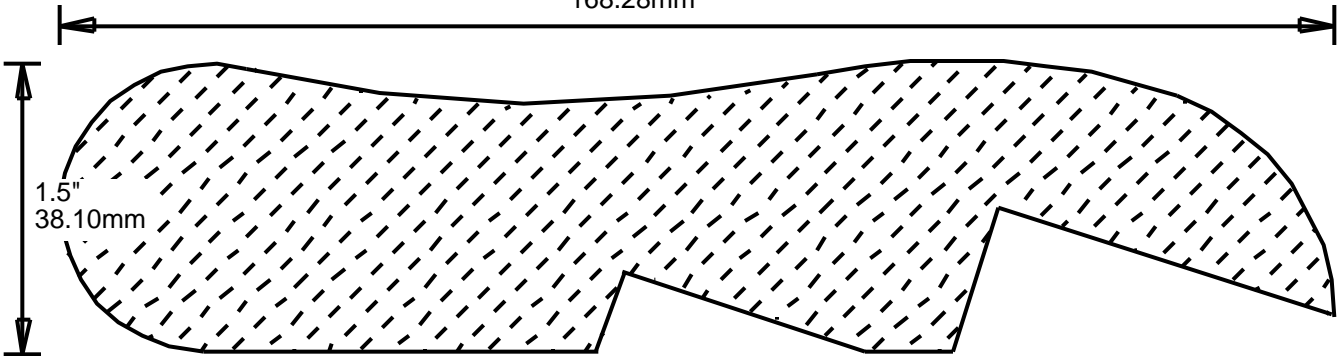

BRR156701

6.7"  
170.18mm

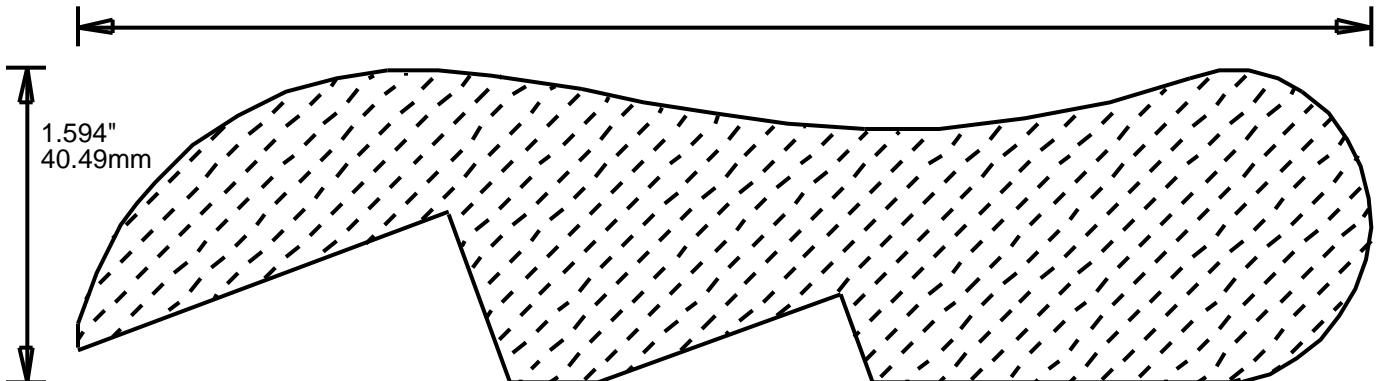

# WEINIG RAIL MOULDING PATTERNS

## BAR RAILS

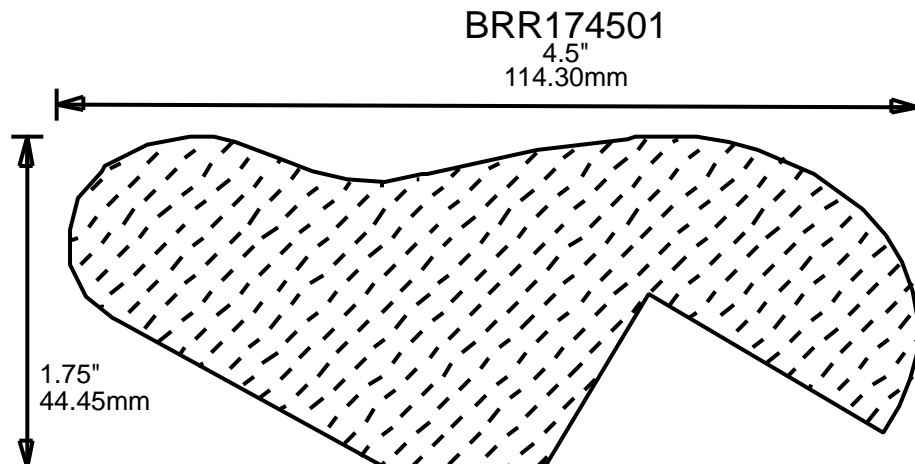
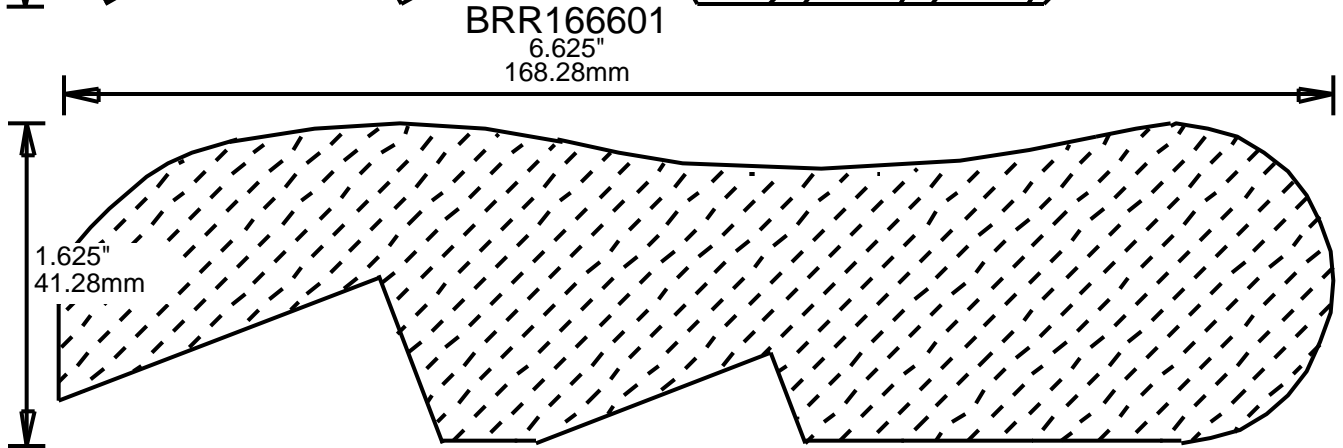
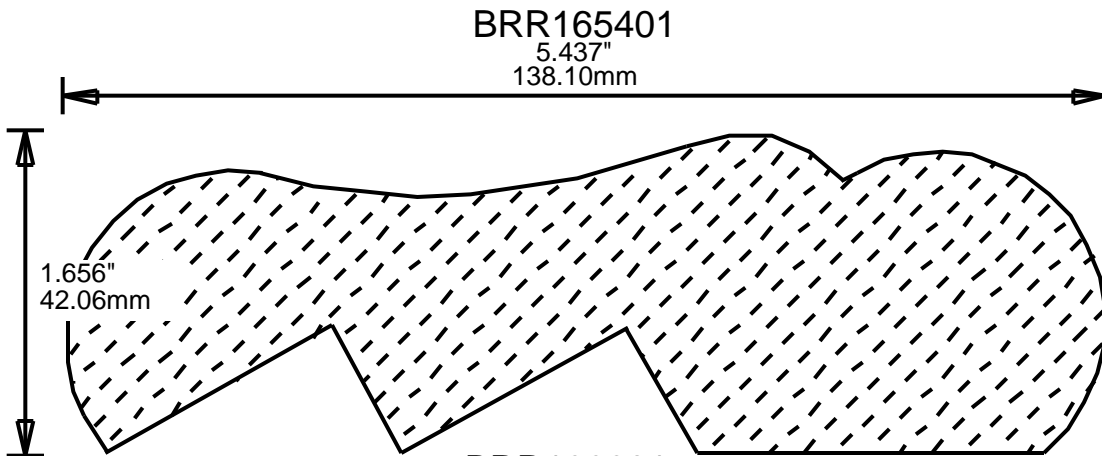
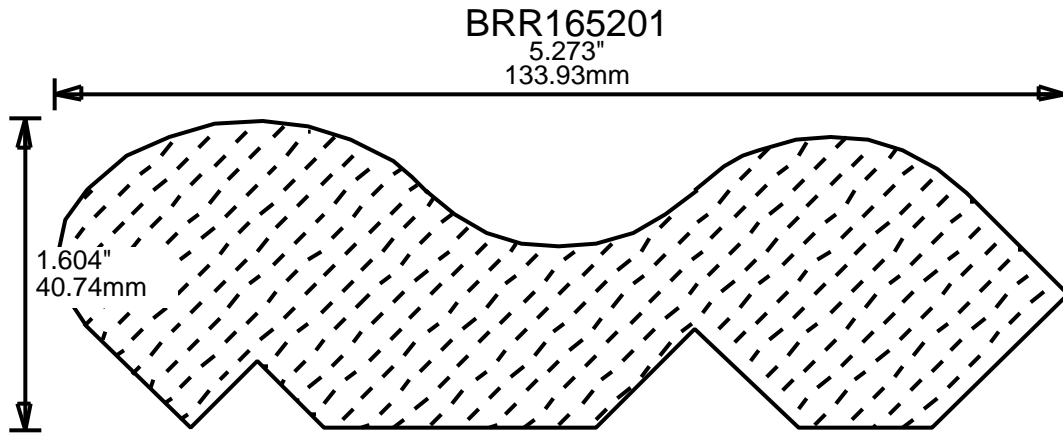

[RETURN TO Table of Contents](#)

[PRINT THIS PAGE](#)

# WEINIG RAIL MOULDING PATTERNS

## BAR RAILS

BRR175201

5.25"  
133.35mm

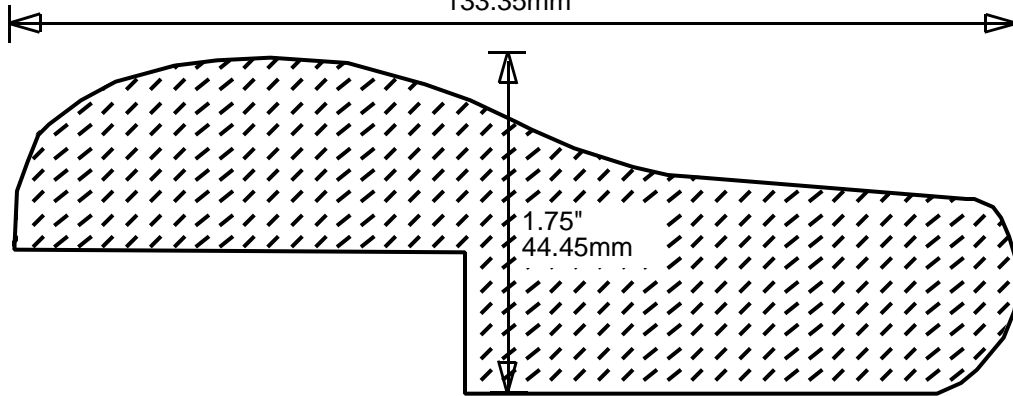

BRR175501

5.5"  
139.70mm

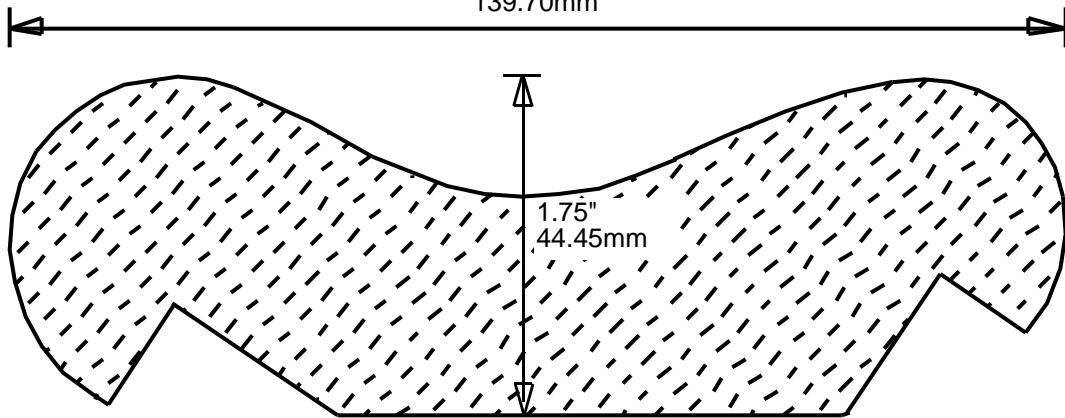

BRR176101

6.125"  
155.58mm

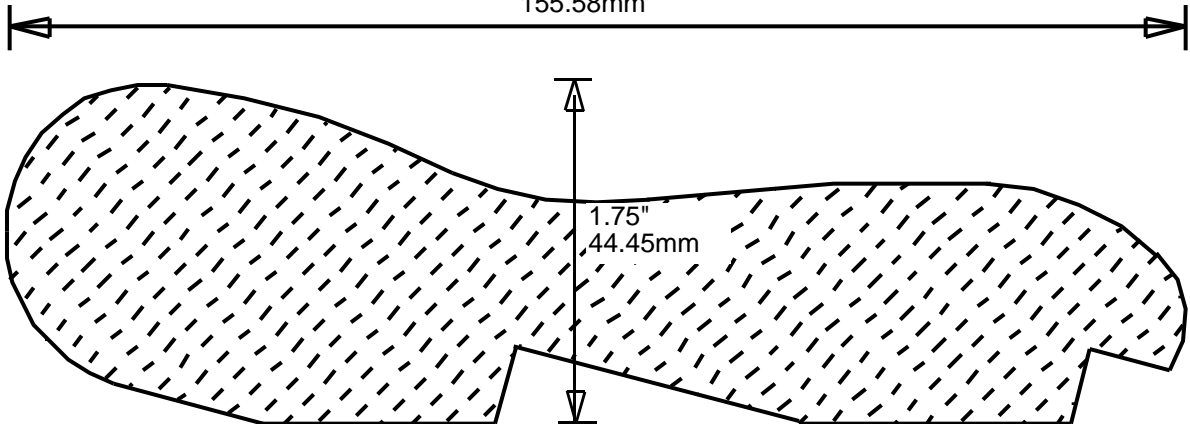

BRR167001

7.063"  
179.40mm

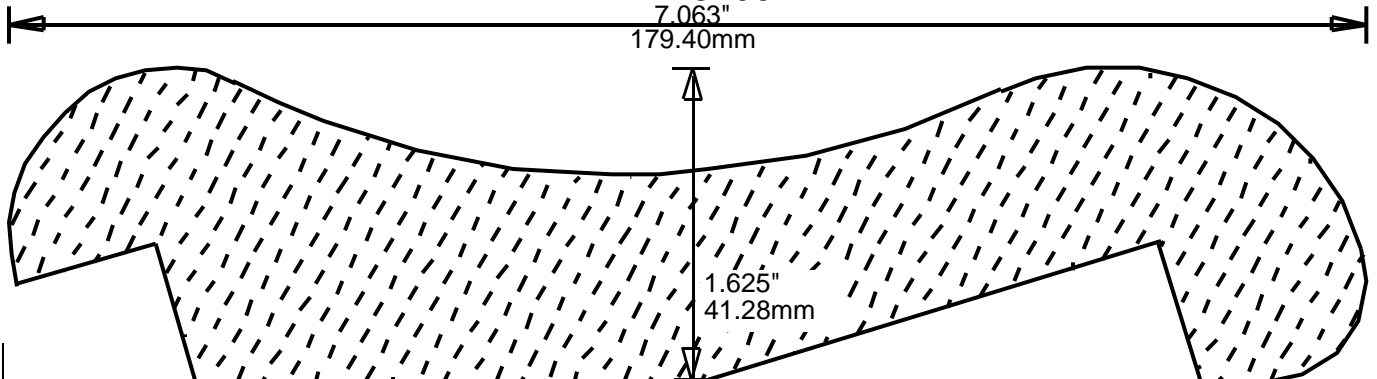

# WEINIG RAIL MOULDING PATTERNS

## CHAIR RAILS

CH10240  
2.437"  
61.90mm

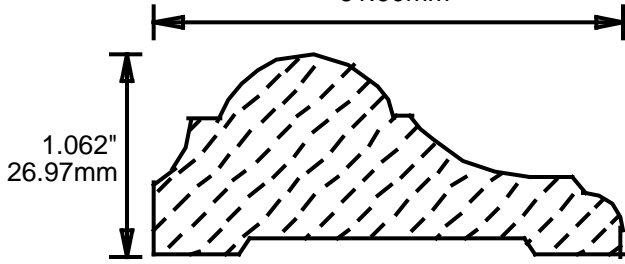

CH10250  
2.5"  
63.50mm

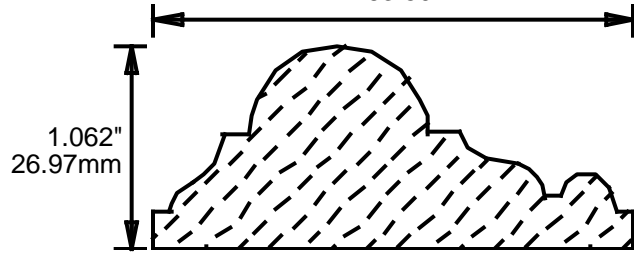

CH10271  
2.75"  
69.85mm

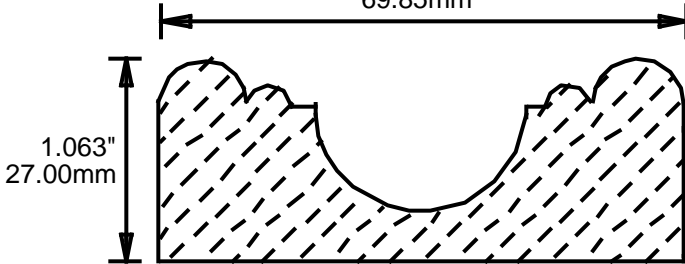

CH10272  
2.75"  
69.85mm

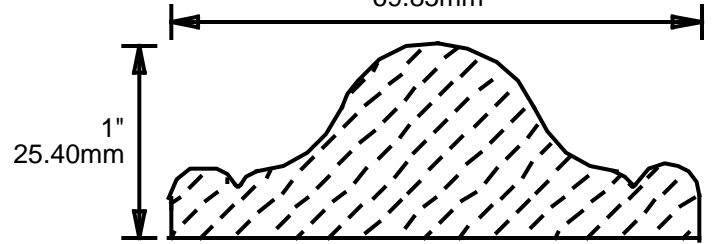

CH10281  
2.875"  
73.03mm

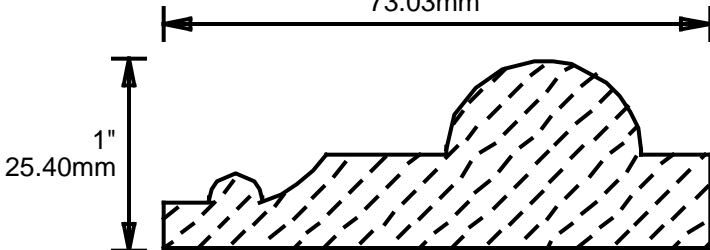

CH10310  
3.125"  
79.38mm

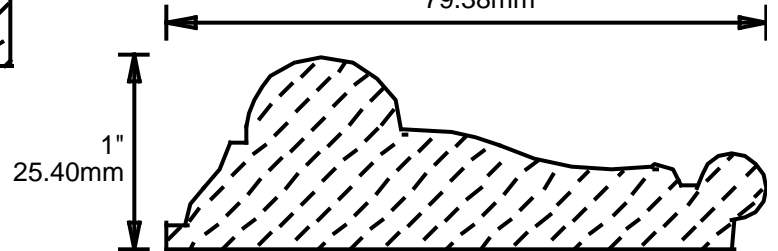

CH10321  
3.25"  
82.55mm

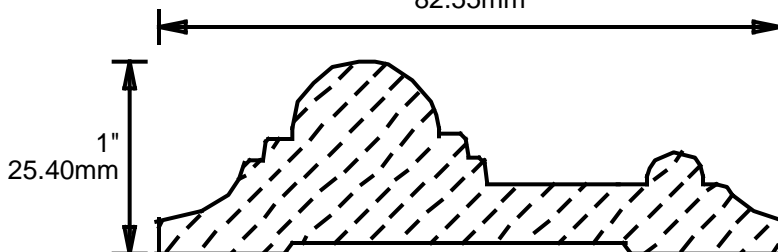

# WEINIG RAIL MOULDING PATTERNS

## CHAIR RAILS

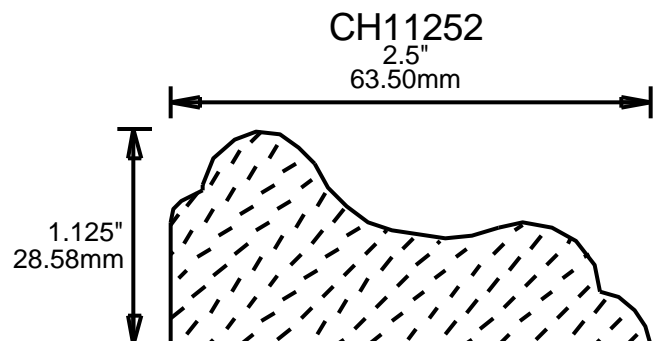
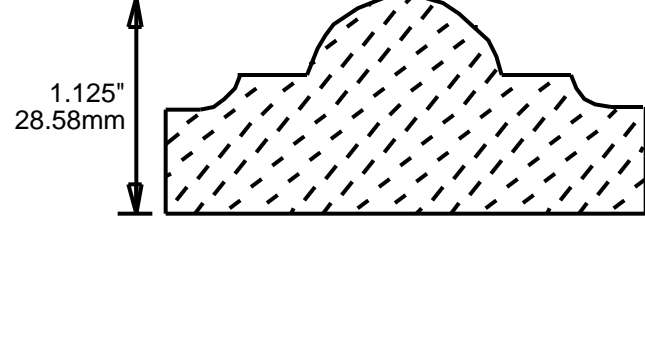
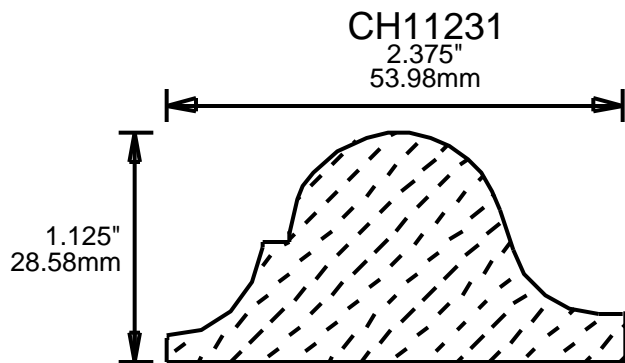
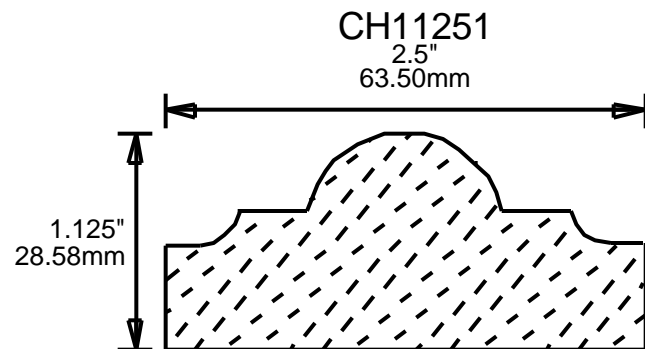
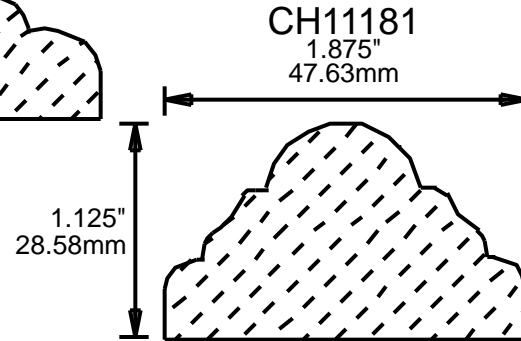
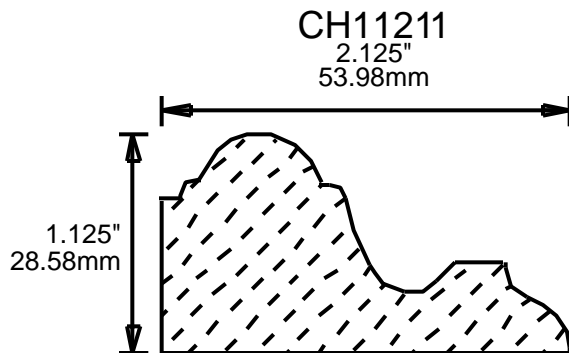
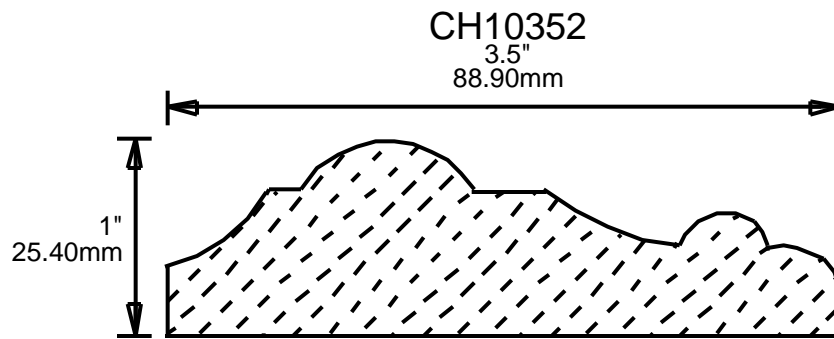
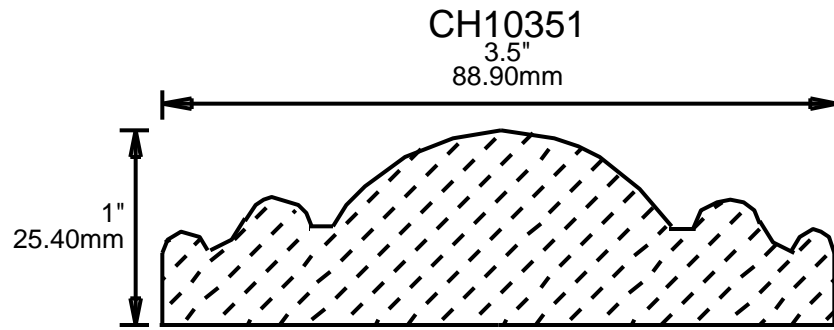

# WEINIG RAIL MOULDING PATTERNS CHAIR RAILS

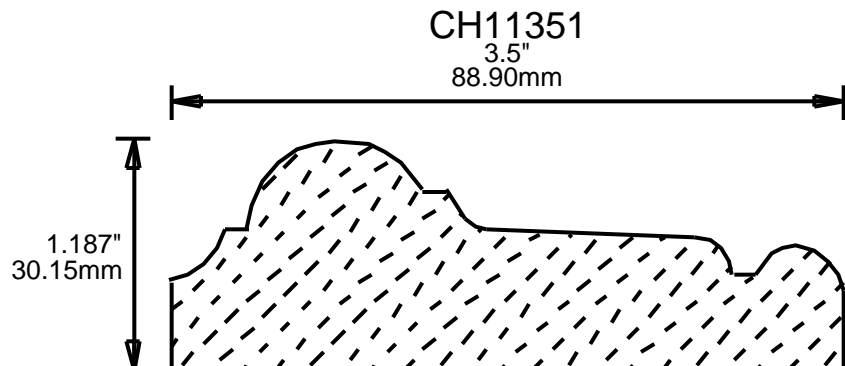
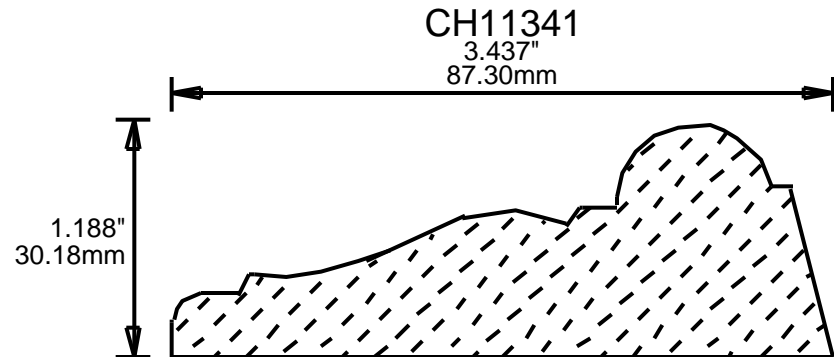
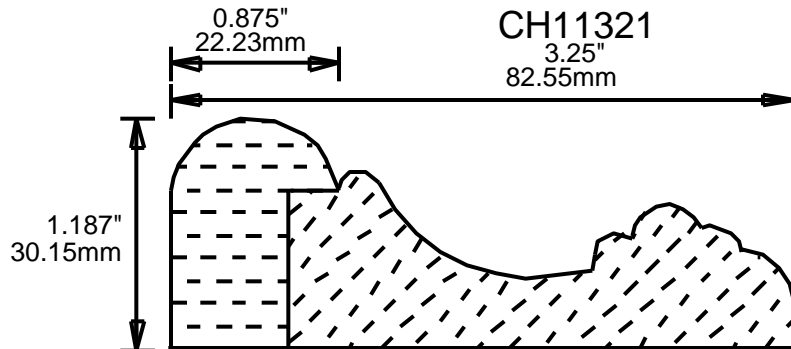
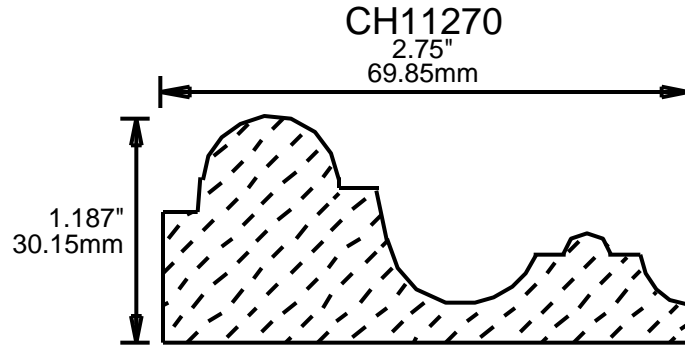
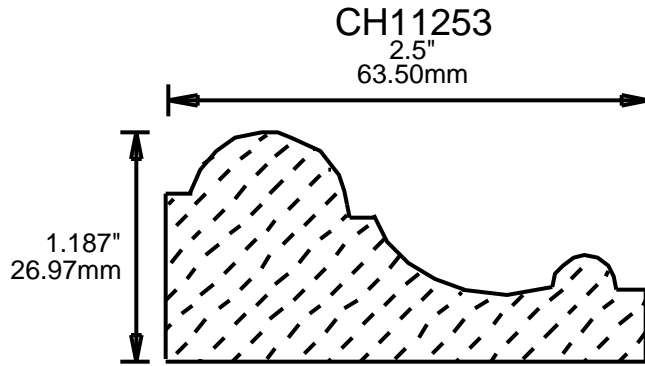
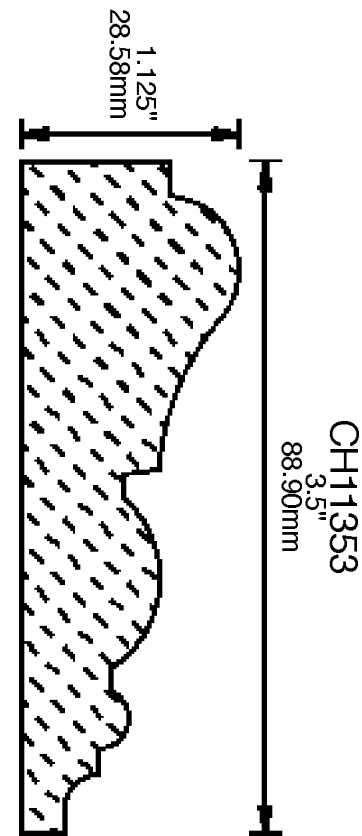
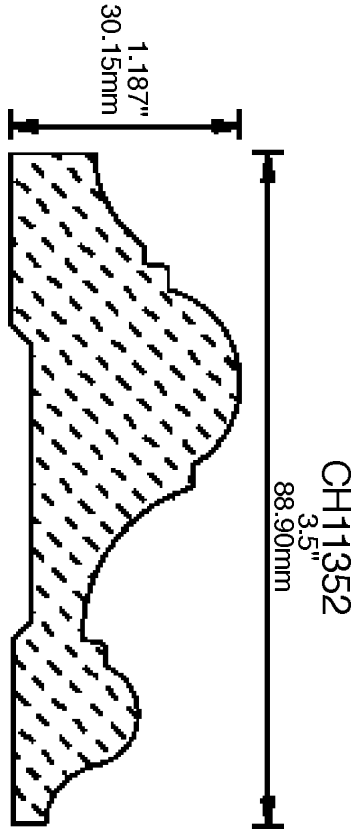

# WEINIG RAIL MOULDING PATTERNS

## CHAIR RAILS

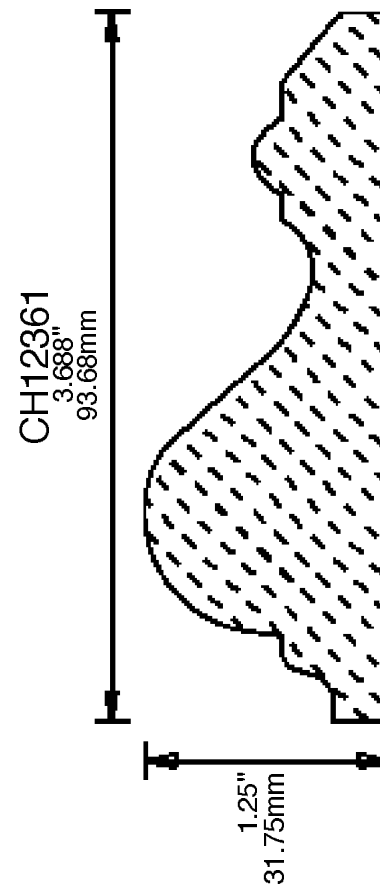
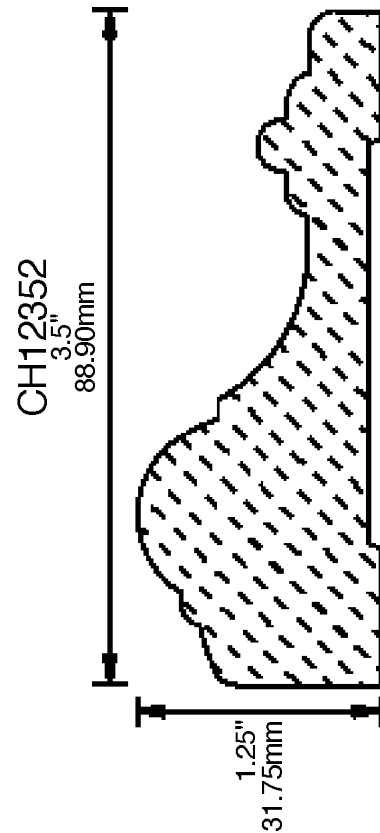
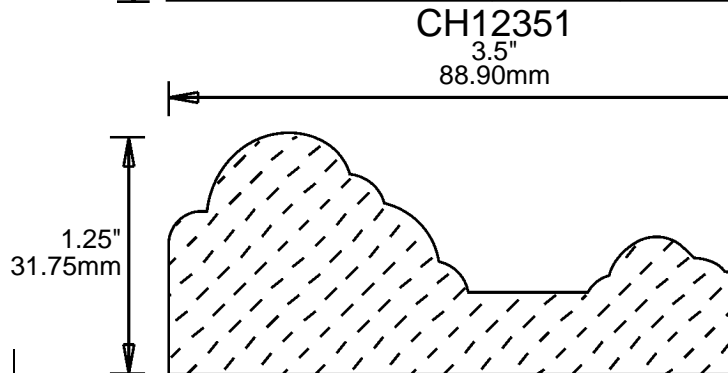
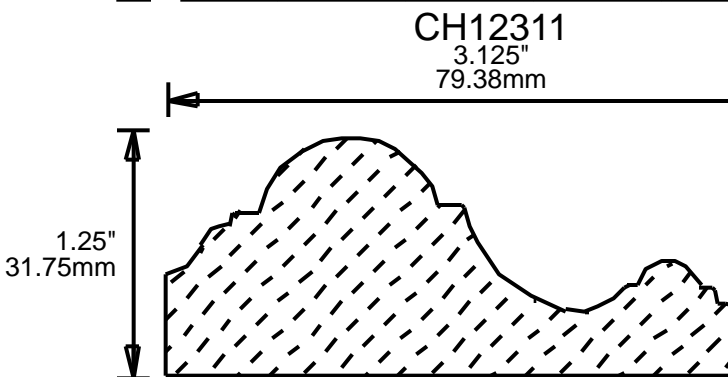
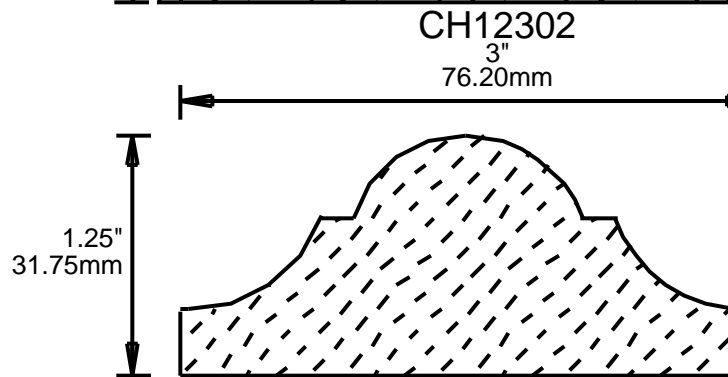
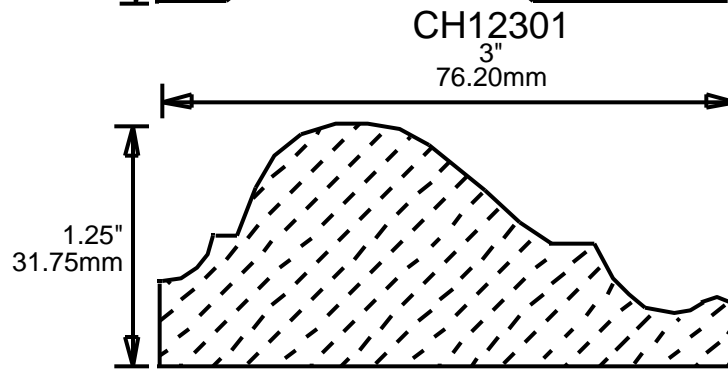
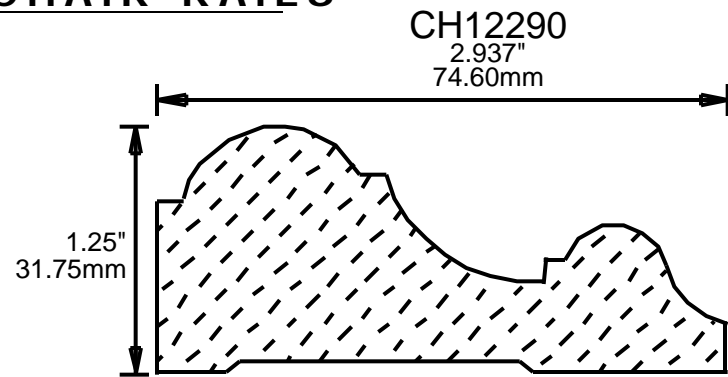



# WEINIG RAIL MOULDING PATTERNS

## CHAIR RAILS

CH12421

4.25"  
107.95mm

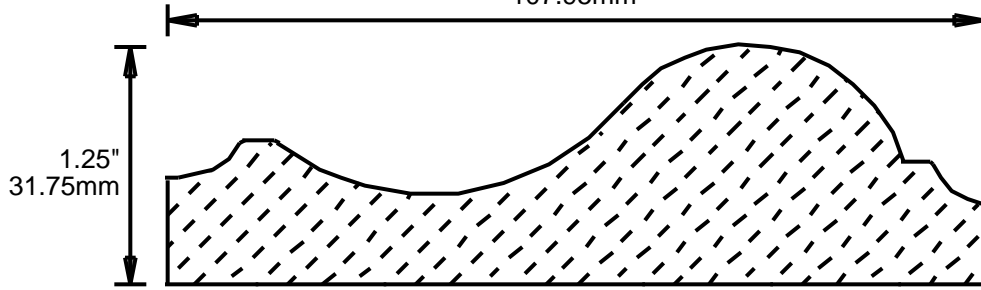

CH12451

4.5"  
114.30mm

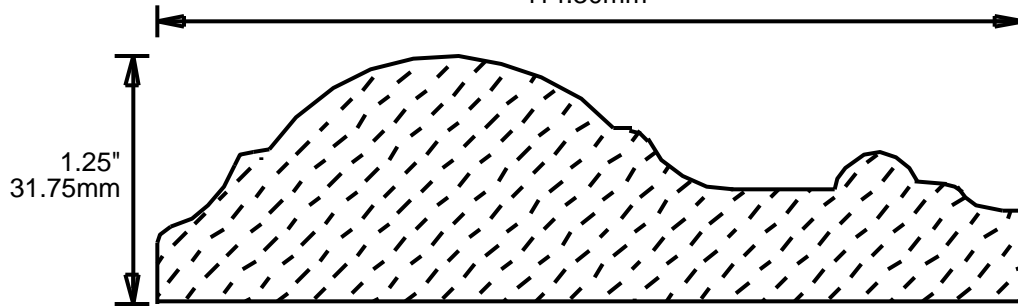

CH13251

2.5"  
63.50mm

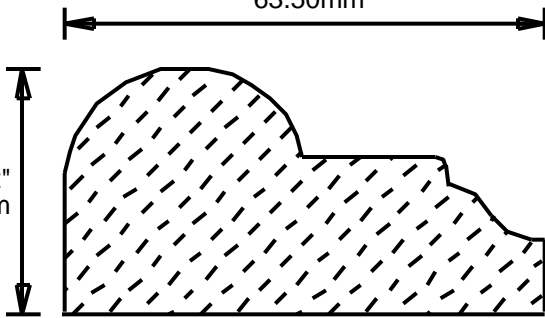

CH13301

3"  
76.20mm

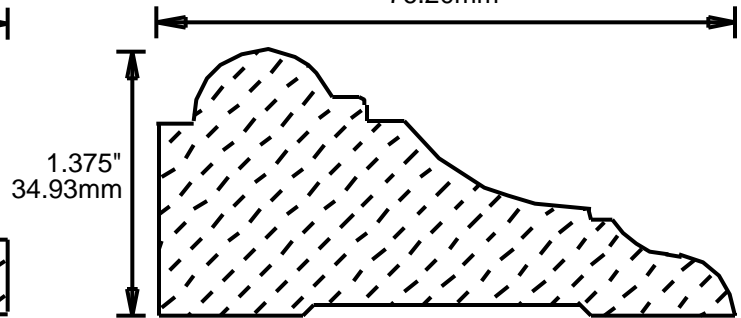

CH13401

4"  
101.60mm

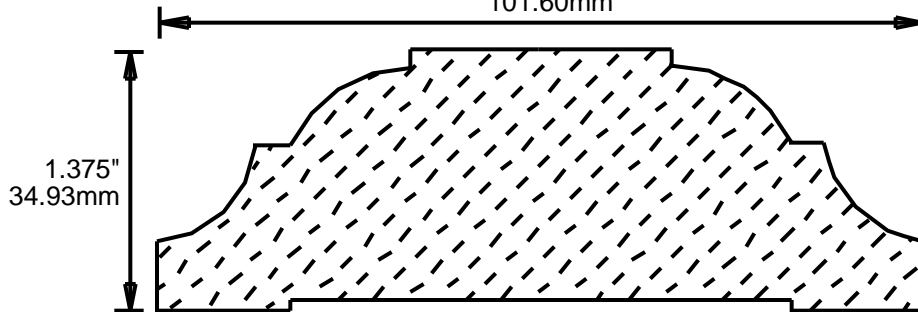

CH15301

3"  
76.20mm

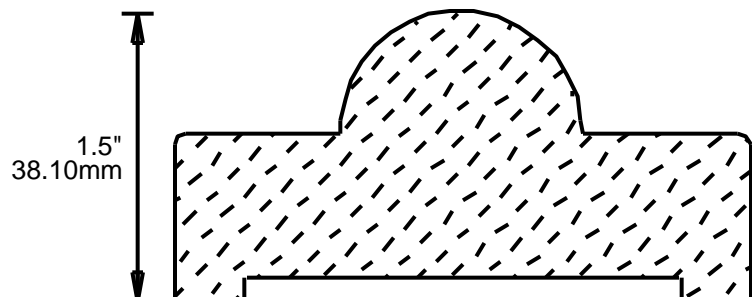

**PRINT  
THIS SECTION**

**RETURN TO  
Table of Contents**

# WEINIG RAIL MOULDING PATTERNS

## CHAIR RAILS

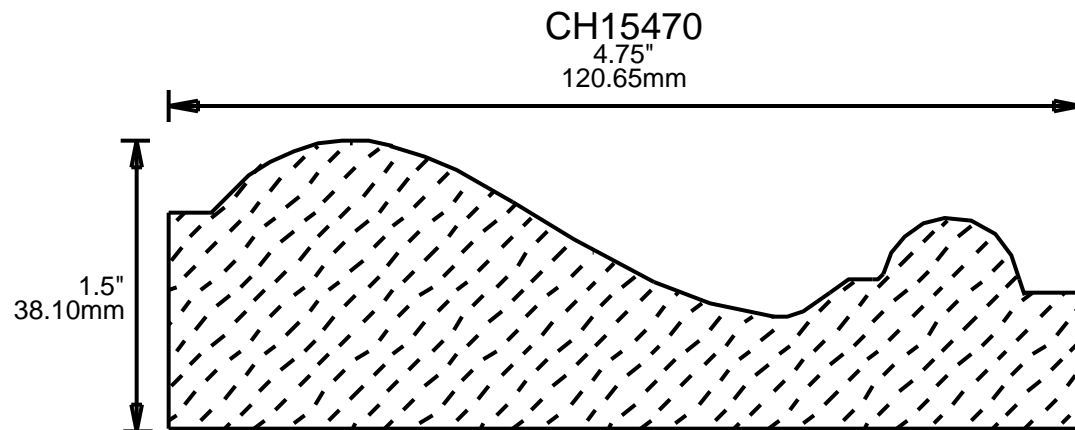
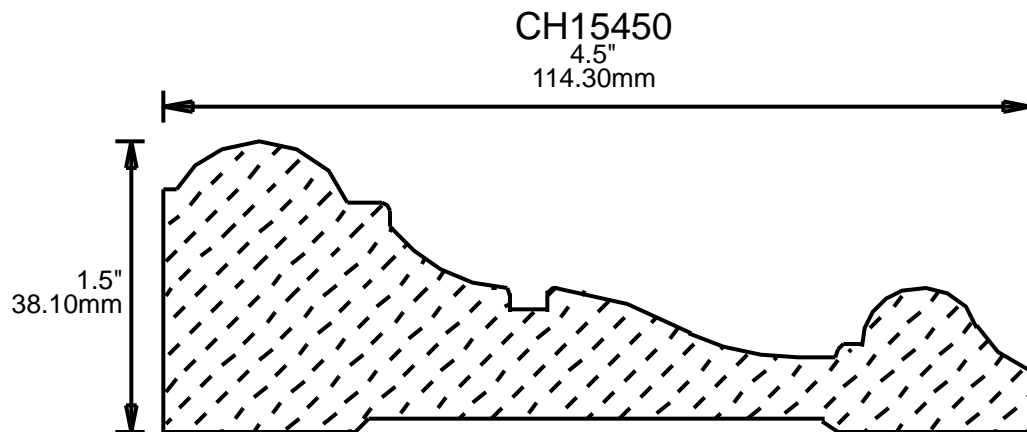
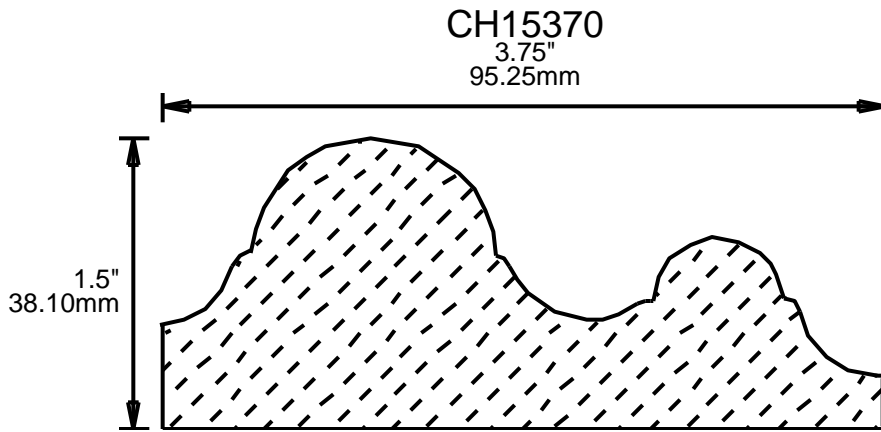
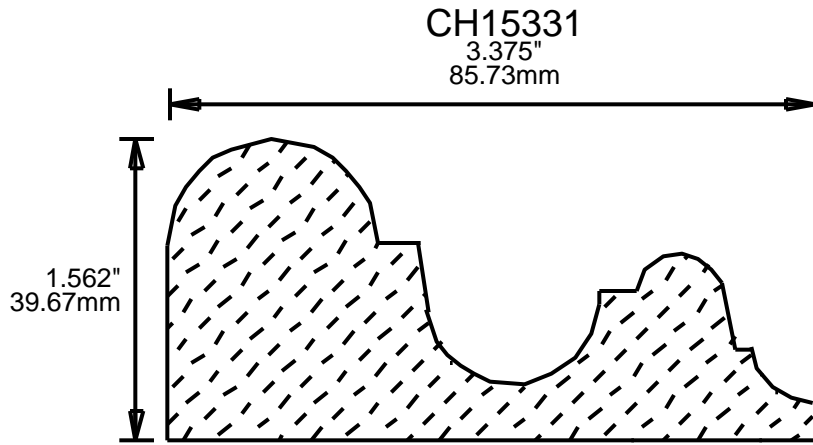

# WEINIG RAIL MOULDING PATTERNS

## CHAIR RAILS

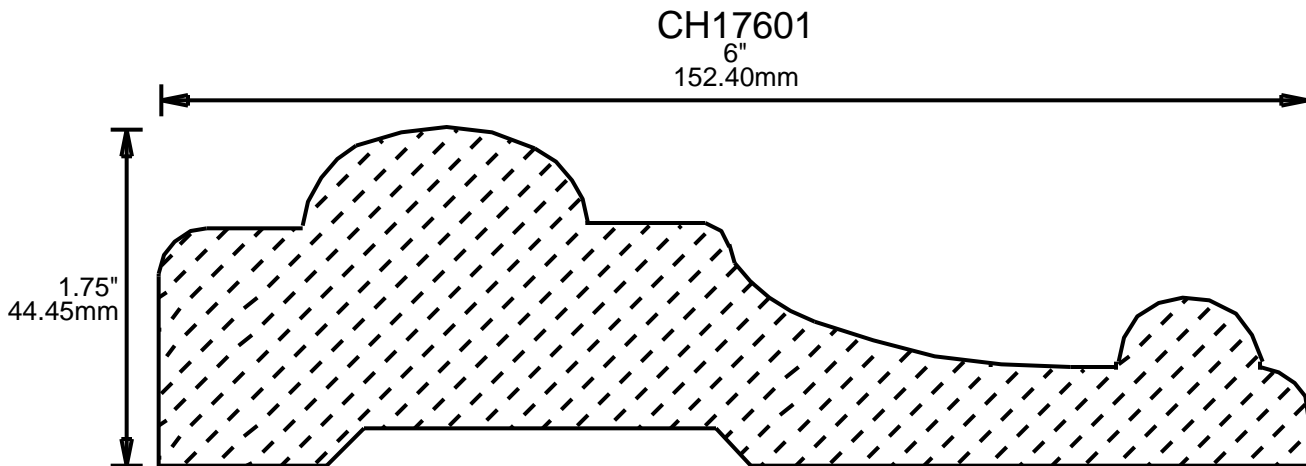
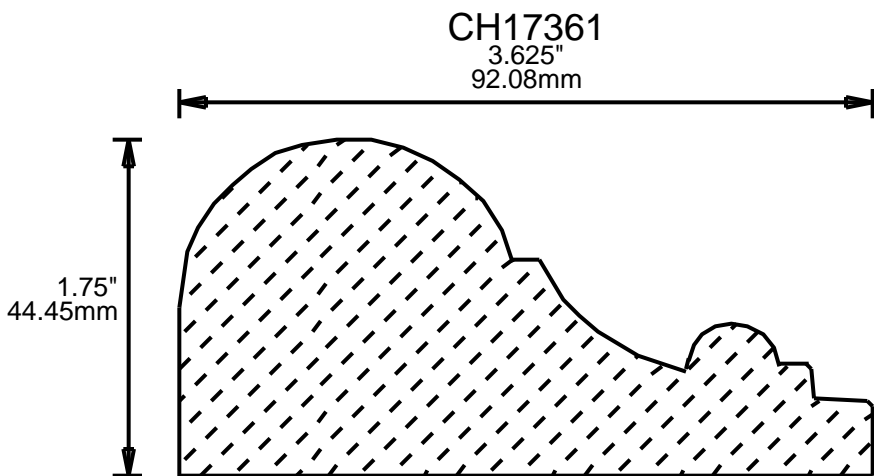
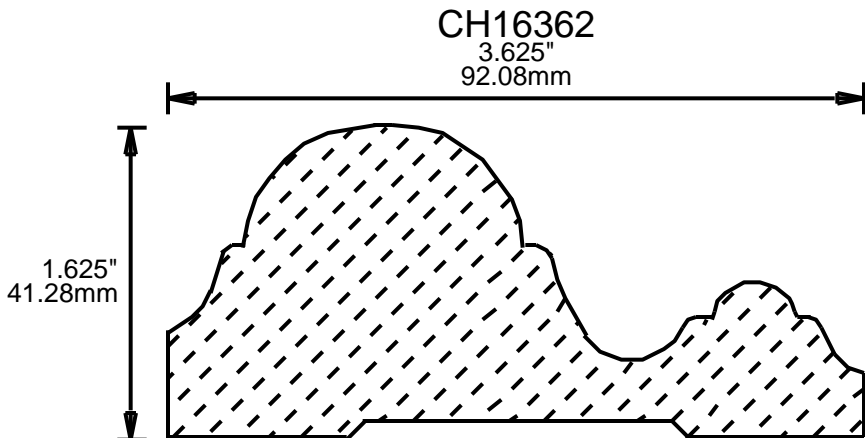
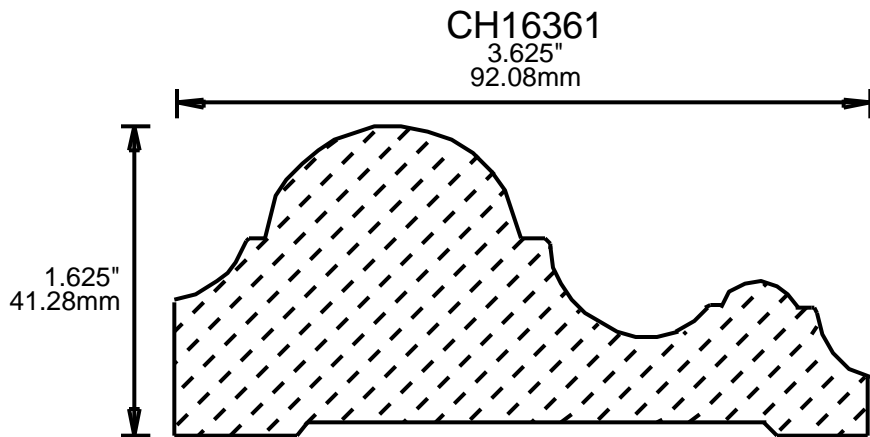

**PRINT  
THIS SECTION**

**RETURN TO  
Table of Contents**

# WEINIG RAIL MOULDING PATTERNS

## CHAIR RAILS

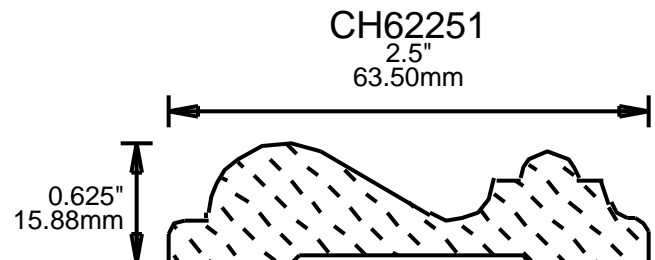
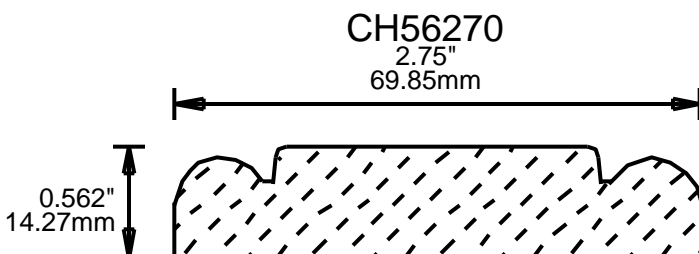
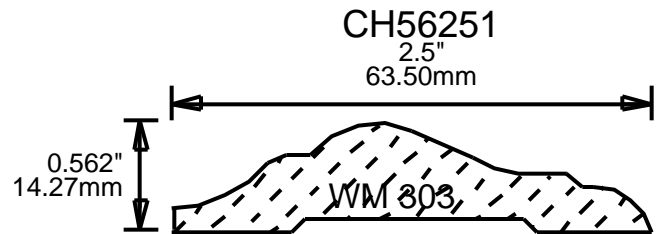
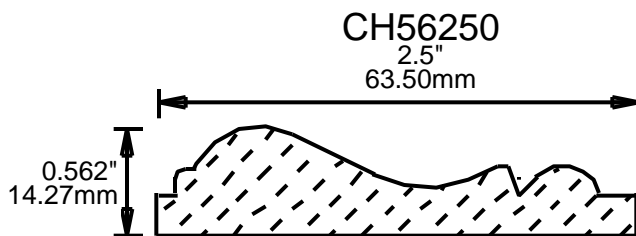
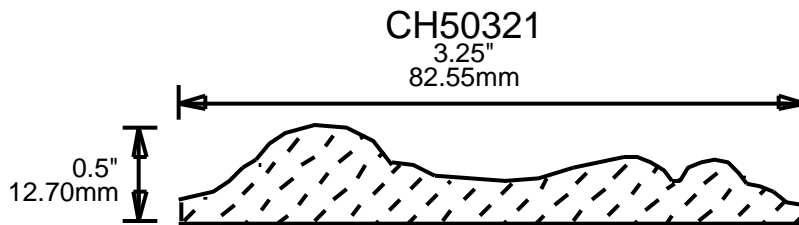
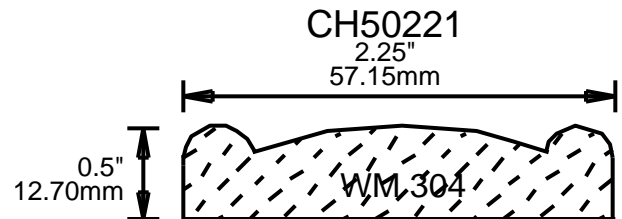
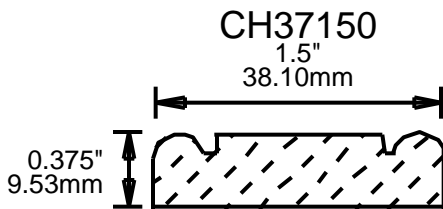
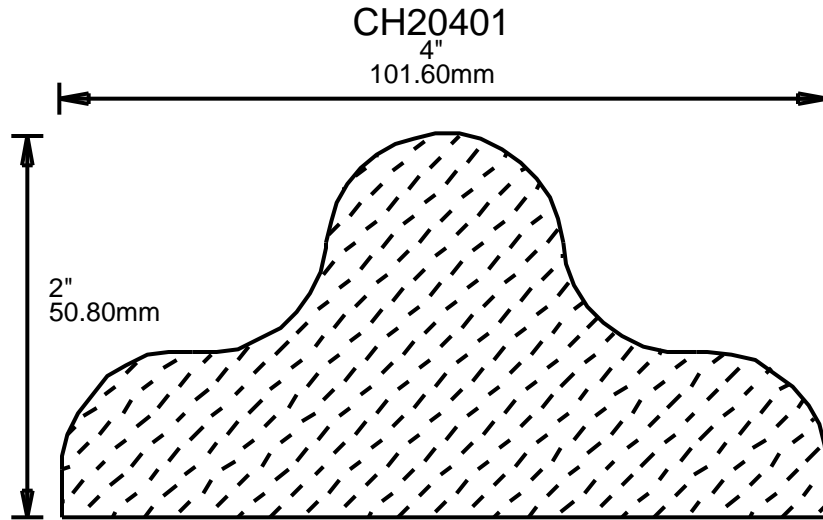

# WEINIG RAIL MOULDING PATTERNS CHAIR RAILS

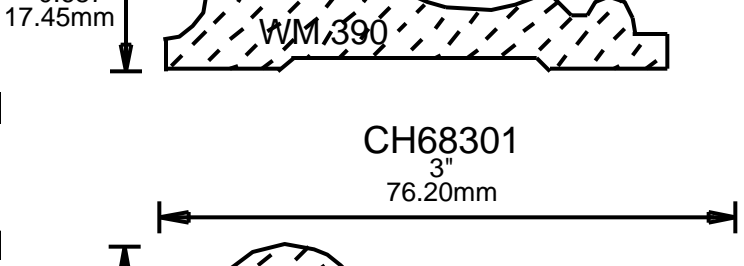
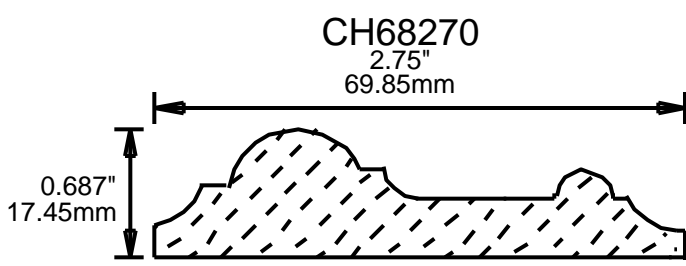
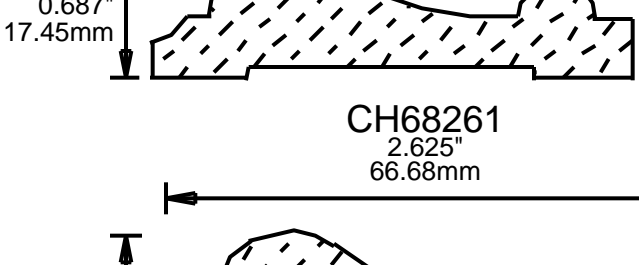
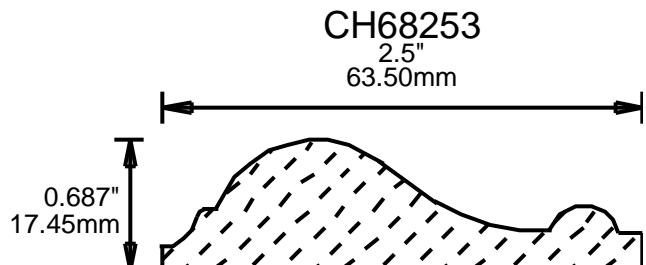
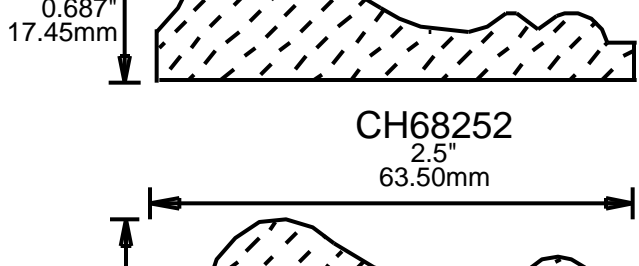
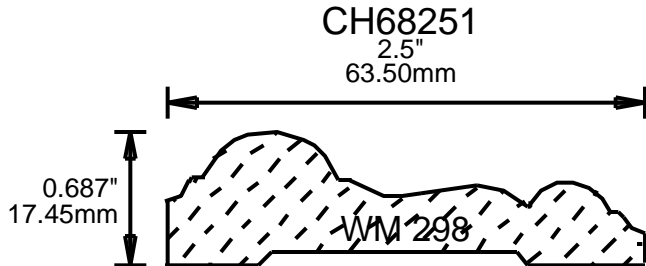
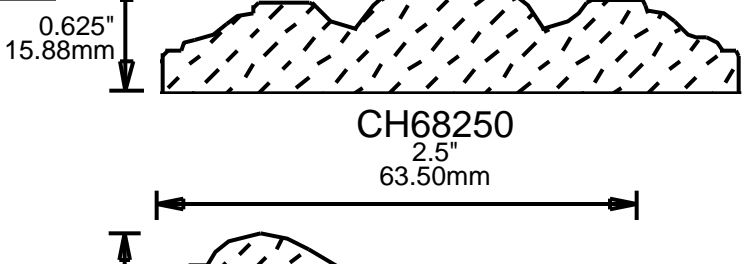
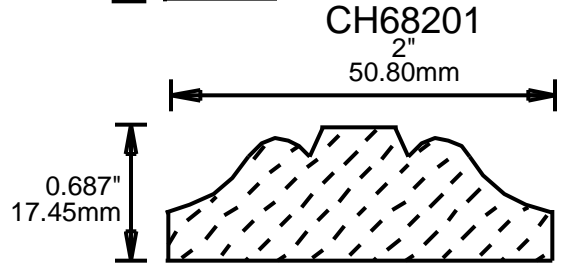
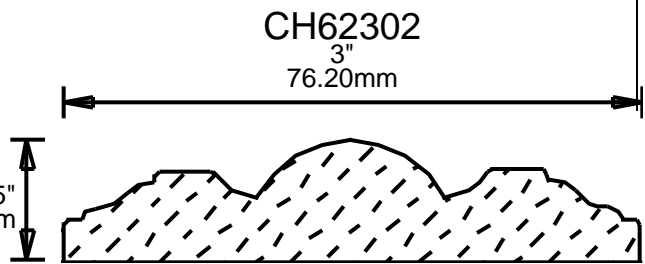
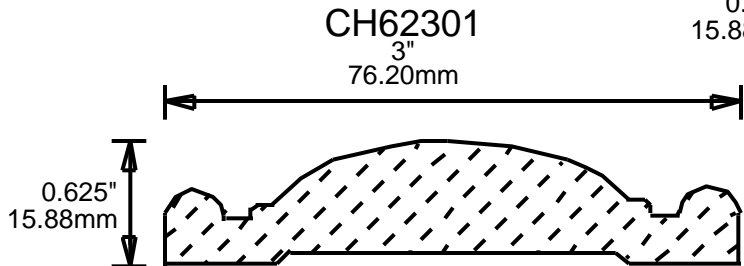
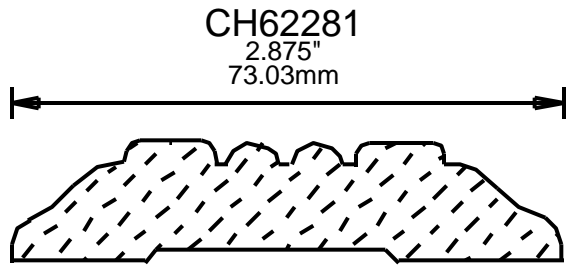
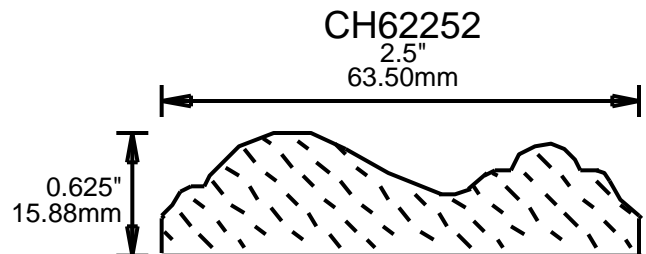

**PRINT  
THIS SECTION**

**RETURN TO  
Table of Contents**

# WEINIG RAIL MOULDING PATTERNS

## CHAIR RAILS

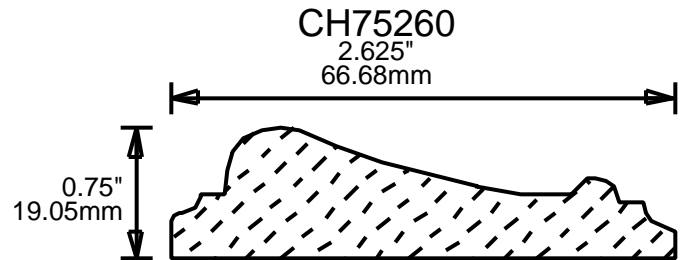
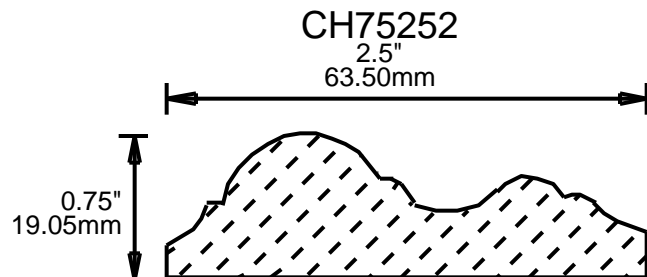
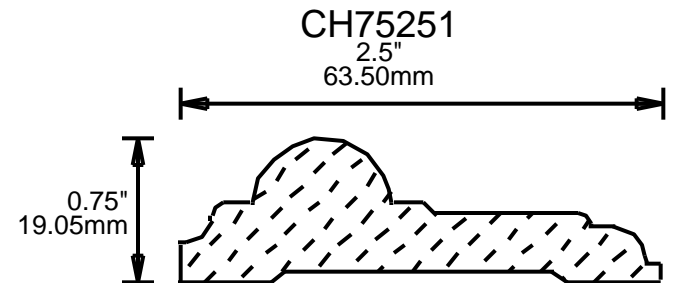
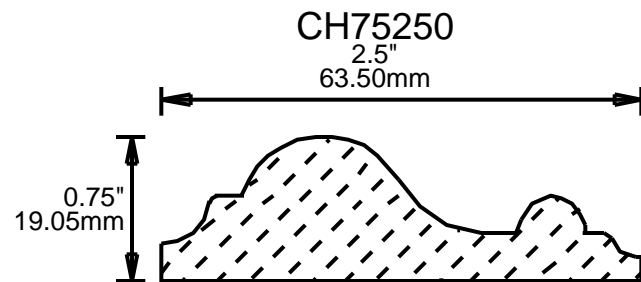
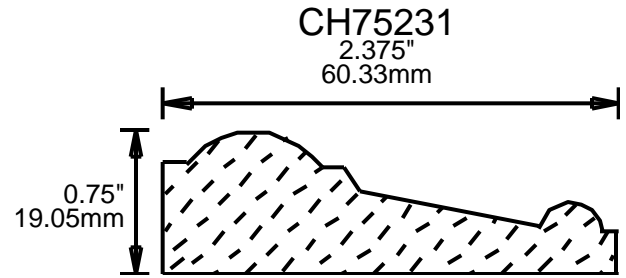
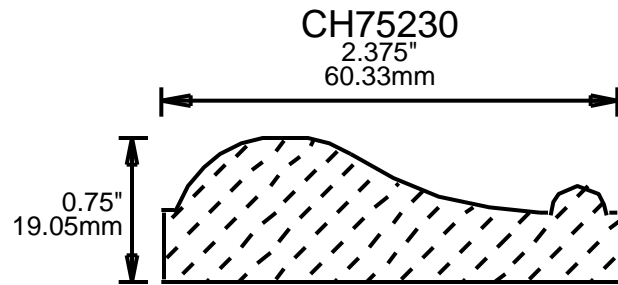
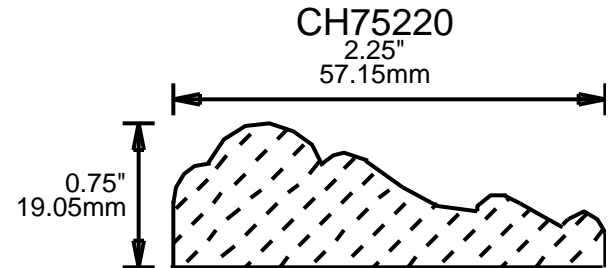
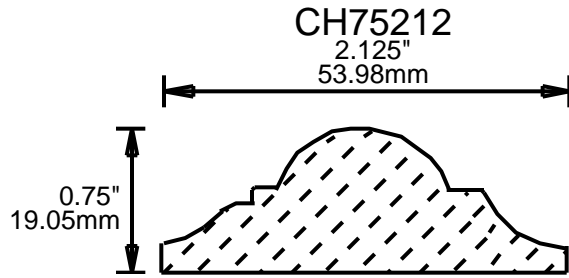
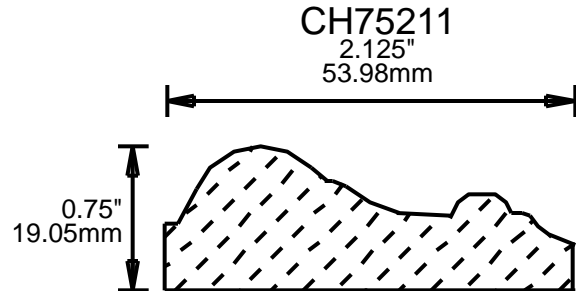
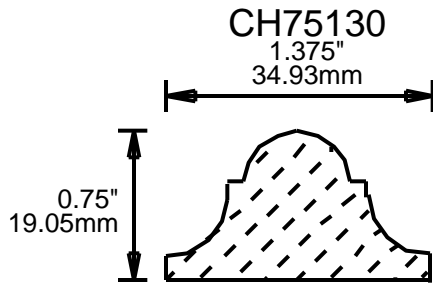

# WEINIG RAIL MOULDING PATTERNS CHAIR RAILS

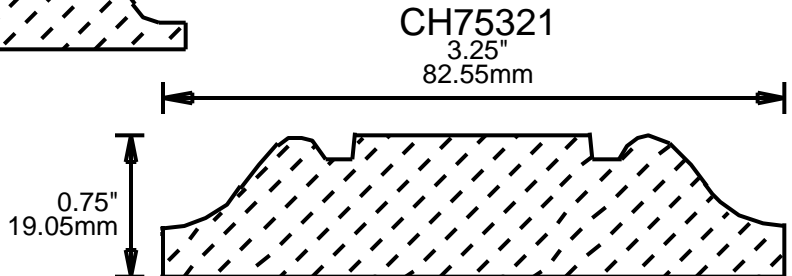
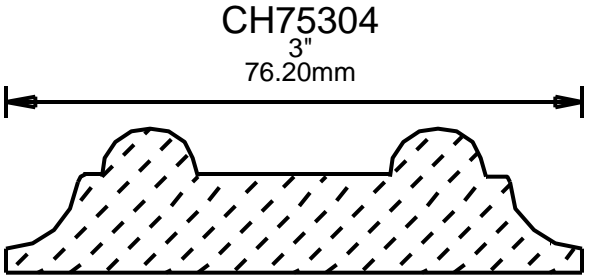
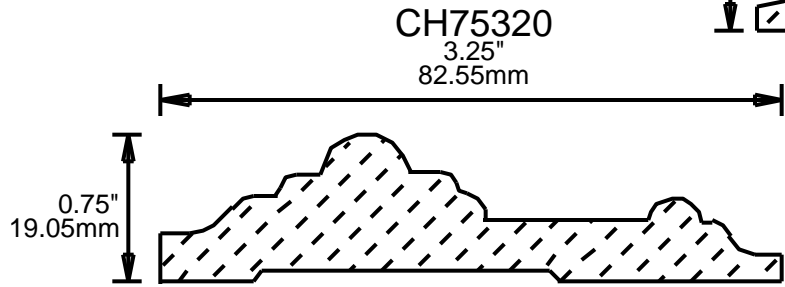
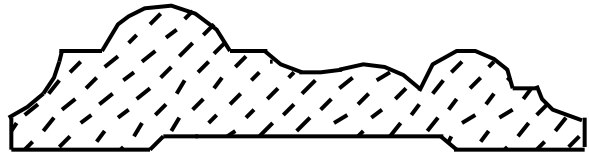
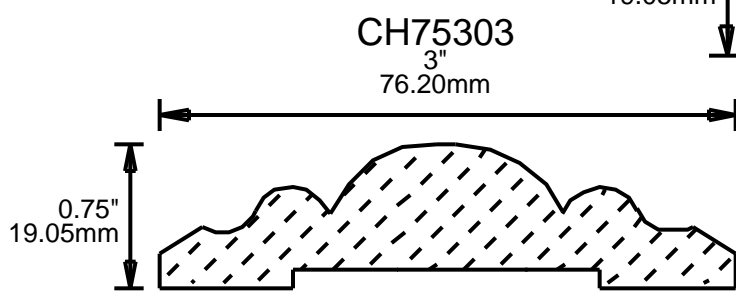
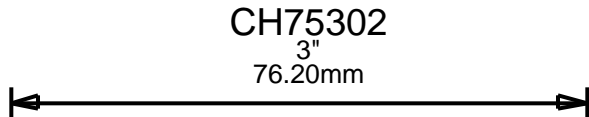
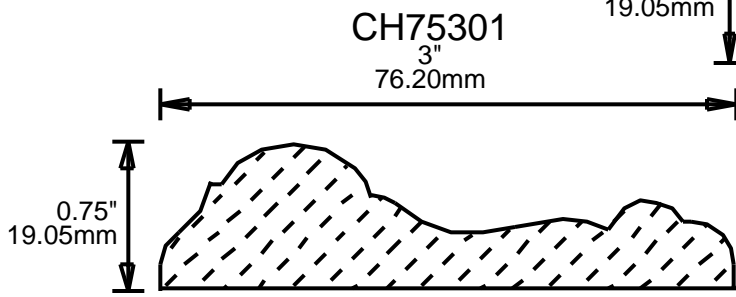
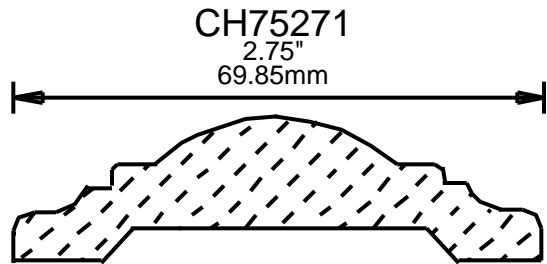
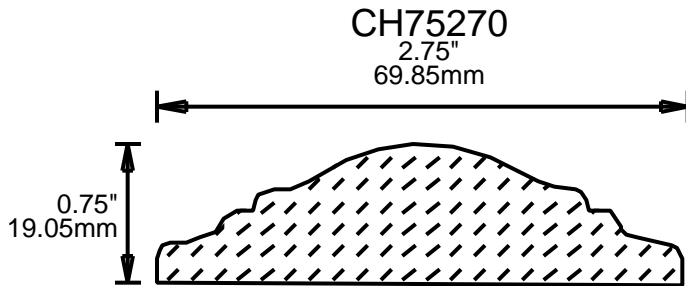

**PRINT  
THIS SECTION**

**RETURN TO  
Table of Contents**

# WEINIG RAIL MOULDING PATTERNS

## CHAIR RAILS

CH75322  
3.25"  
82.55mm

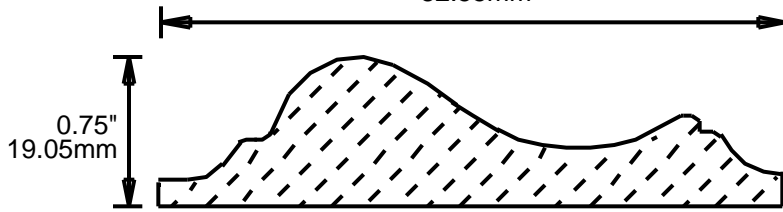

CH75323  
3.25"  
82.55mm

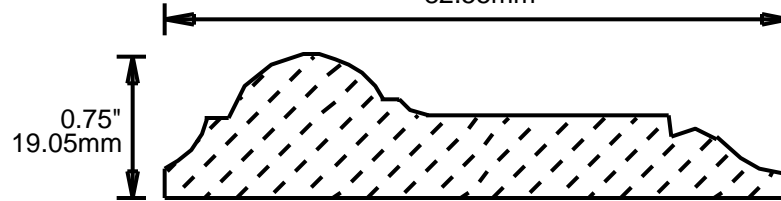

CH75350  
3.5"  
88.90mm

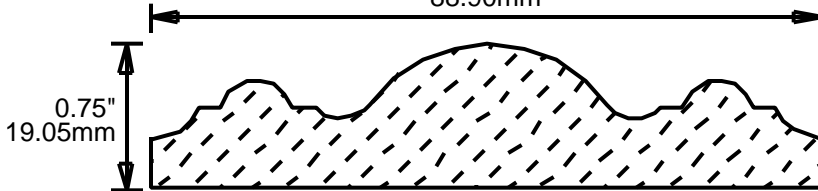

CH75370  
3.75"  
95.25mm

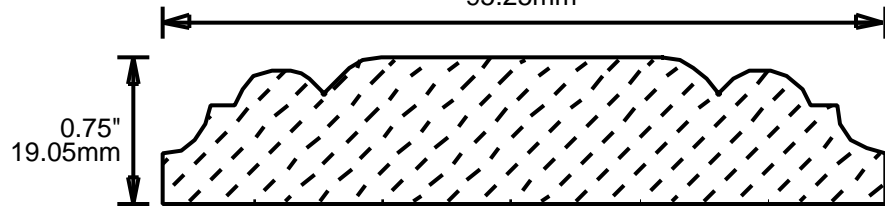

CH75401  
4"  
101.60mm

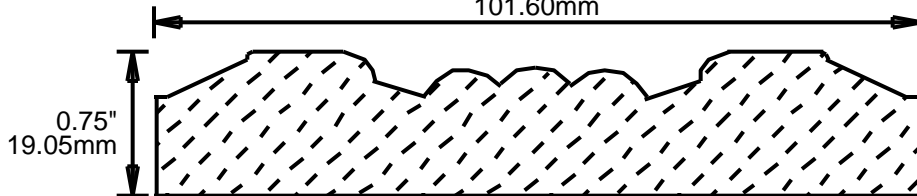

CH75450  
4.5"  
114.30mm





# WEINIG RAIL MOULDING PATTERNS

## CHAIR RAILS

CH81170

1.75"  
44.45mm

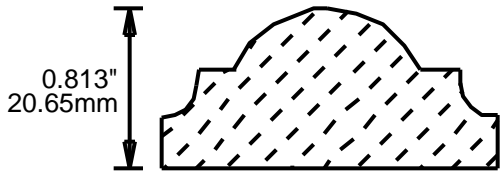

CH81301

3"  
76.20mm

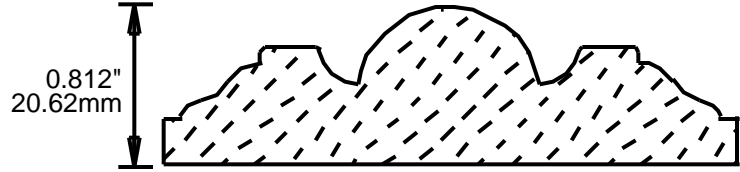

CH81330

3.312"  
84.12

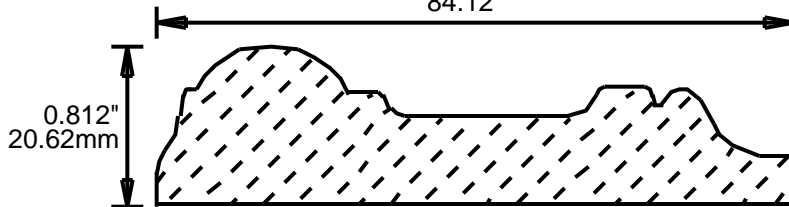

CH81450

4.5"  
114.30mm

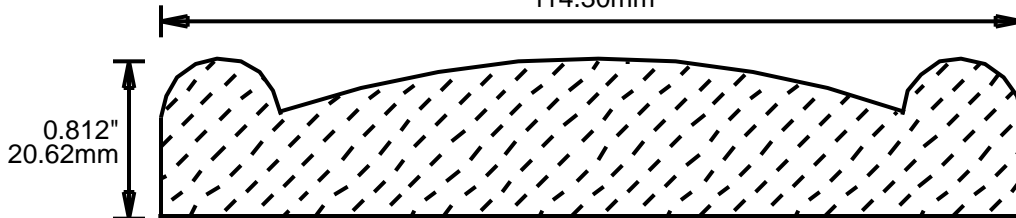

CH81501

5"  
127.00mm

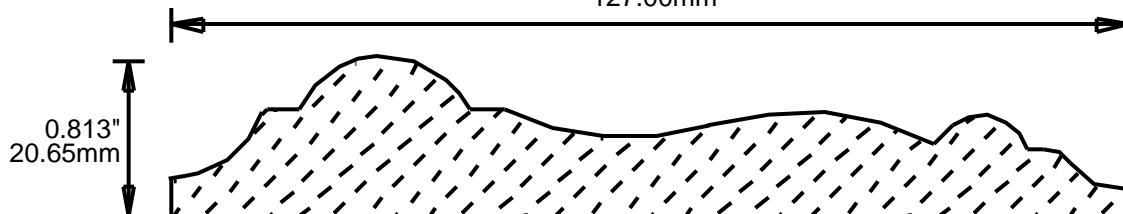

CH87271

2.75"  
69.85mm

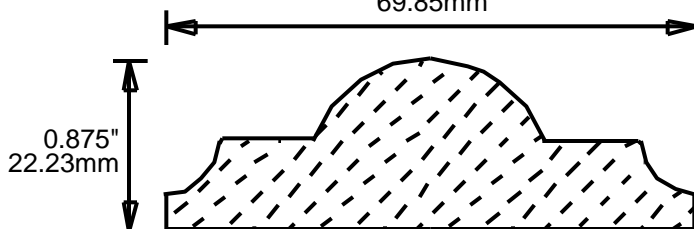

# WEINIG RAIL MOULDING PATTERNS

## CHAIR RAILS

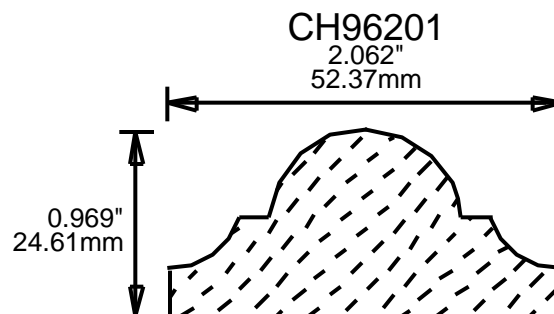
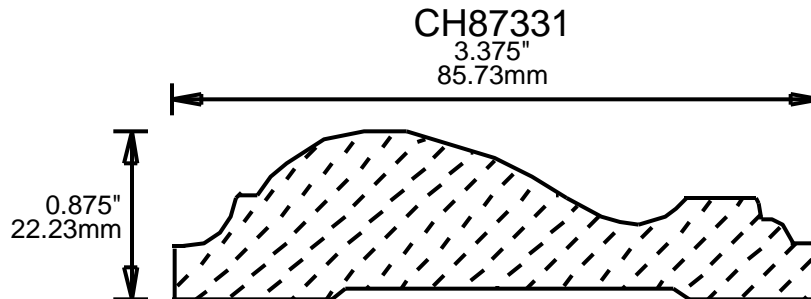
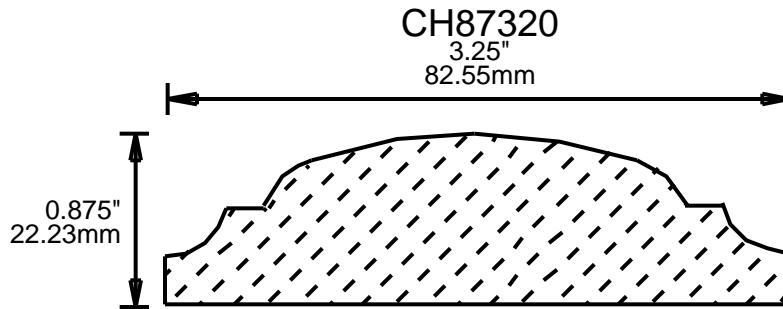
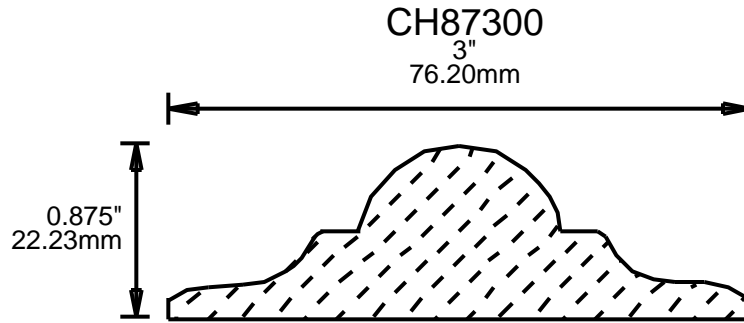

# WEINIG RAIL MOULDING PATTERNS HAND RAILS

HRP110001  
2.437"  
61.90mm

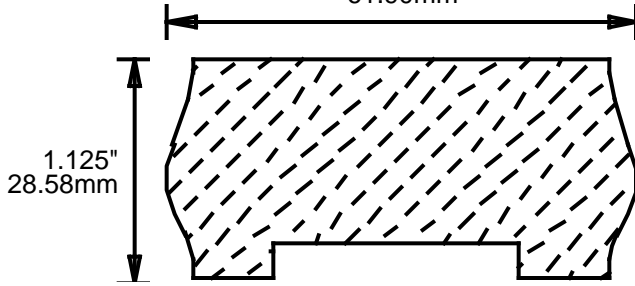

HRP122201  
2.25"  
57.15mm

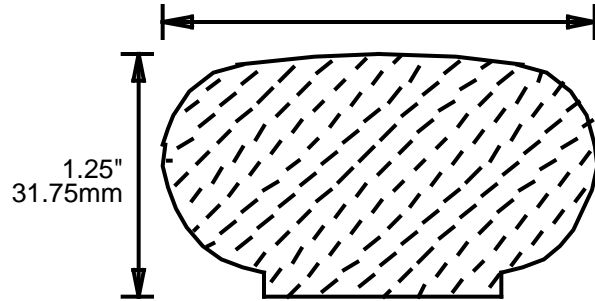

HRP122301  
2.312"  
58.72mm

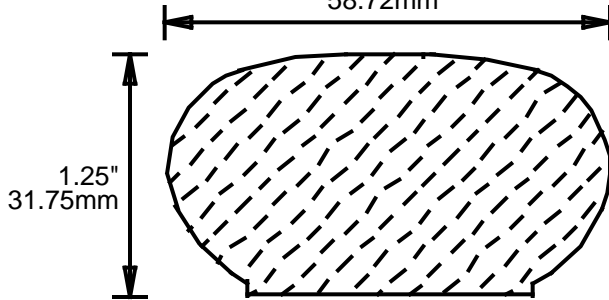

HRP122501  
2.5"  
63.50mm

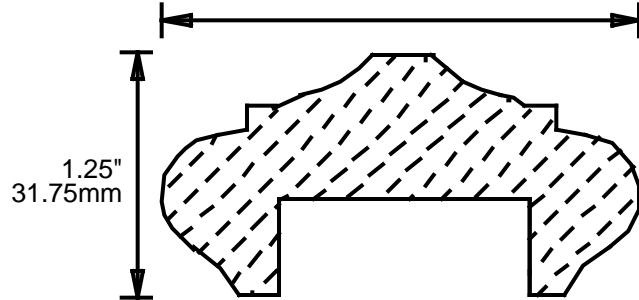

HRP133001  
3"  
76.20mm

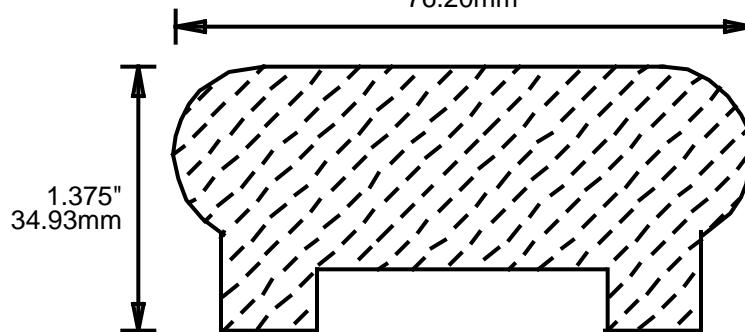

HRP125301  
5.375"  
136.53mm

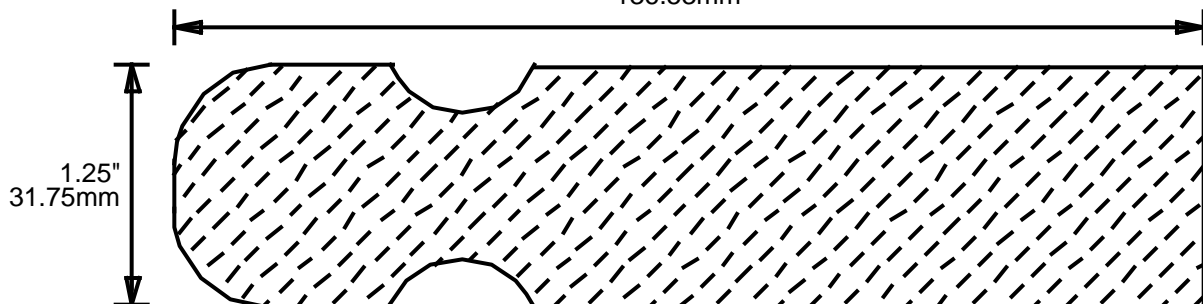

# WEINIG RAIL MOULDING PATTERNS

## HAND RAILS

HRP132201

2.25"  
57.15mm

1.375"  
34.93mm

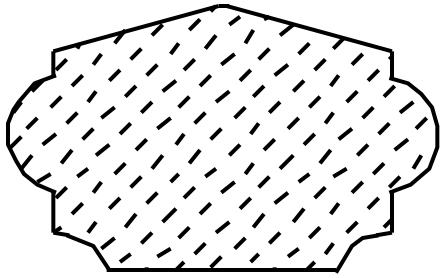

HRP133201

3.25"  
82.55mm

1.375"  
34.93mm

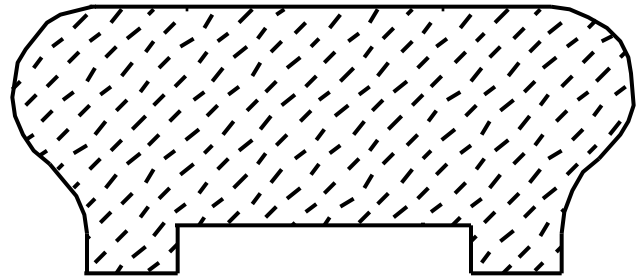

HRP145301

5.375"  
136.53mm

1.406"  
35.71mm

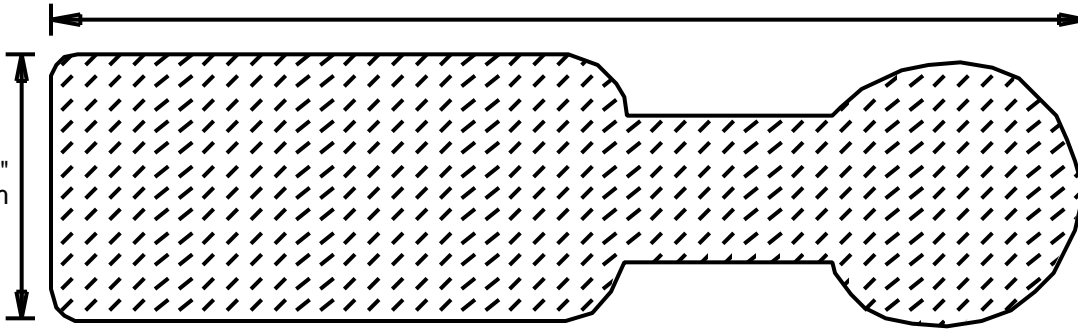

HRP153502

5.5"  
139.70mm

1.375"  
34.93mm

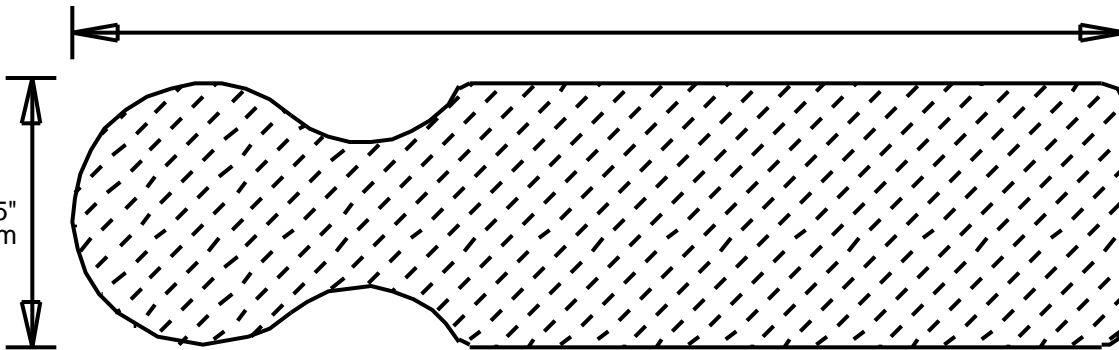

# WEINIG RAIL MOULDING PATTERNS HAND RAILS

HRP154701  
4.75"  
120.65mm

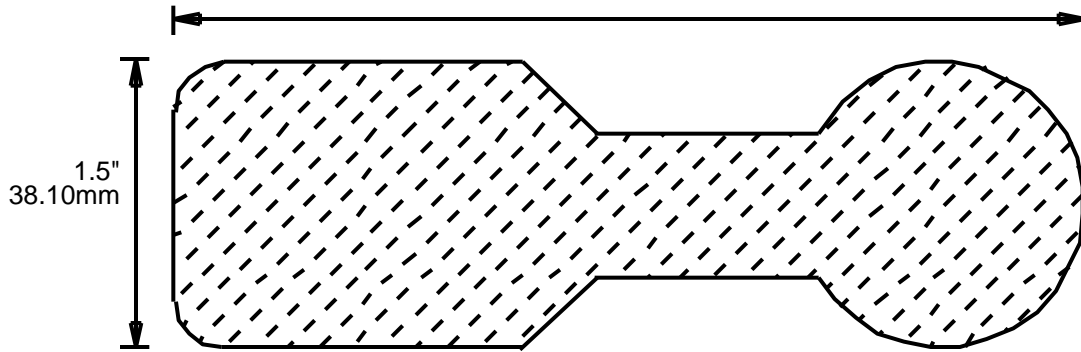

HRP155200  
5.25"  
133.35mm

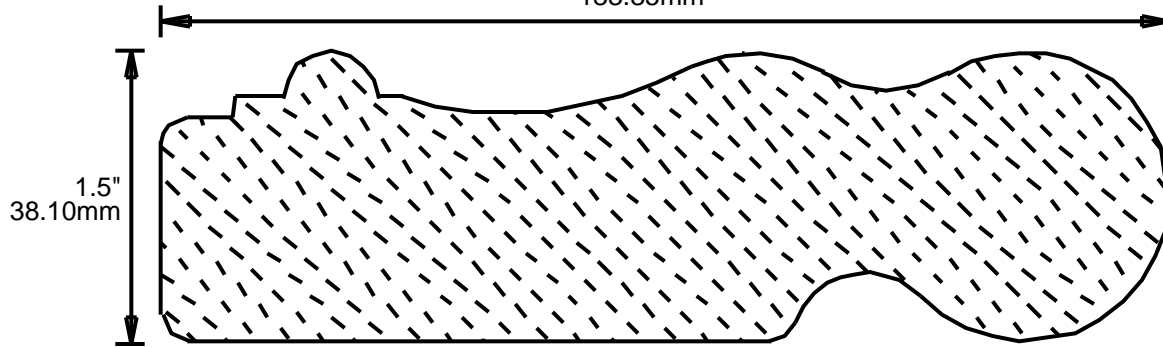

HRP155201  
5.25"  
133.35mm

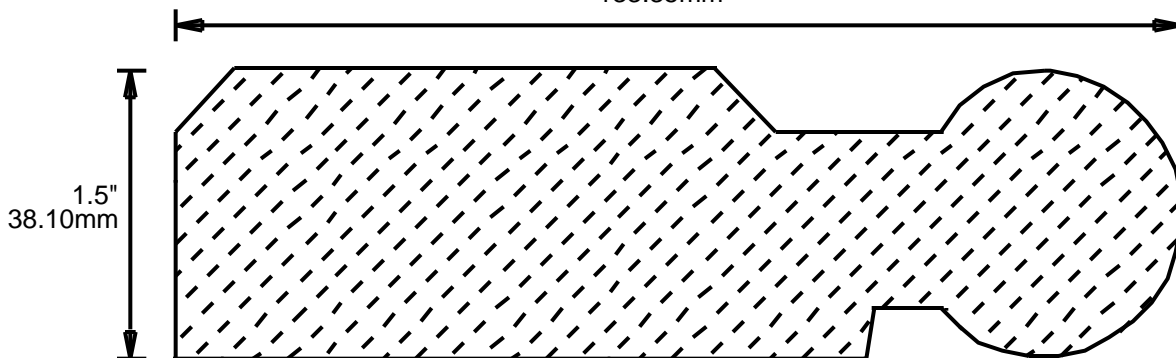

HRP155500  
5.5"  
139.70mm

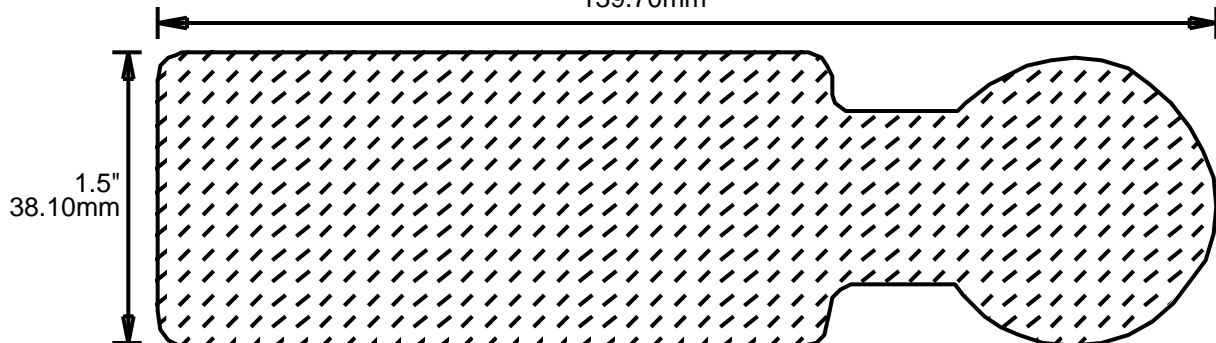

**PRINT  
THIS SECTION**

**RETURN TO  
Table of Contents**

# WEINIG RAIL MOULDING PATTERNS

## HAND RAILS

HRP155501

5.5"  
139.70mm

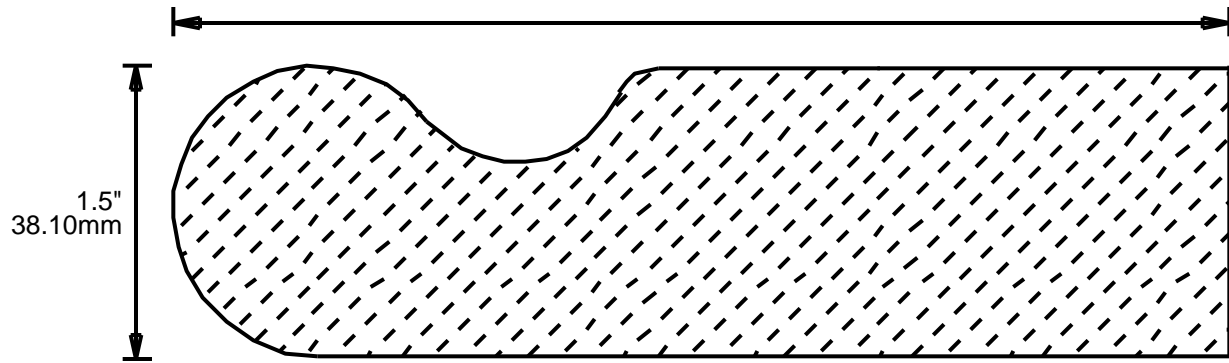

HRP155503

5.5"  
139.70mm

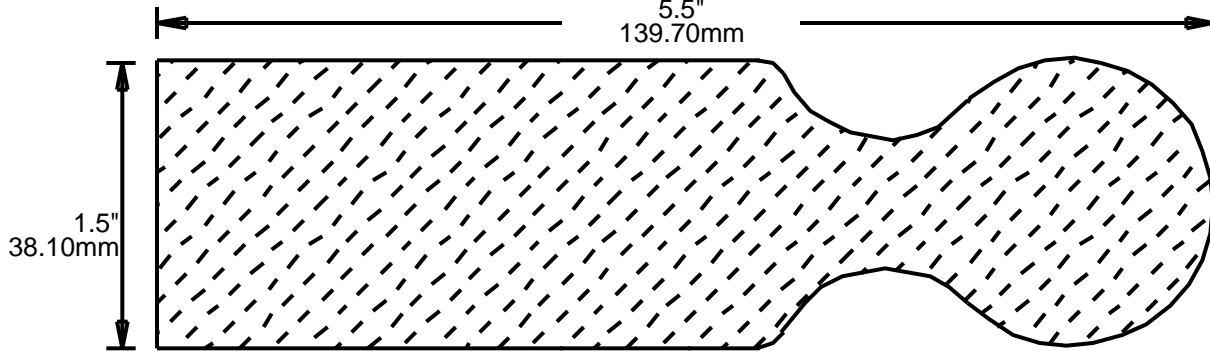

HRP162801

2.875"  
73.03mm

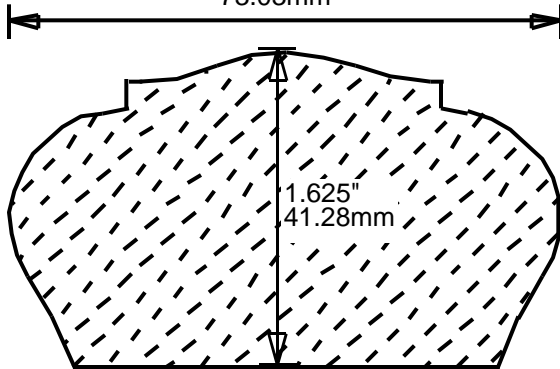

HRP172901

2.938"  
74.63mm

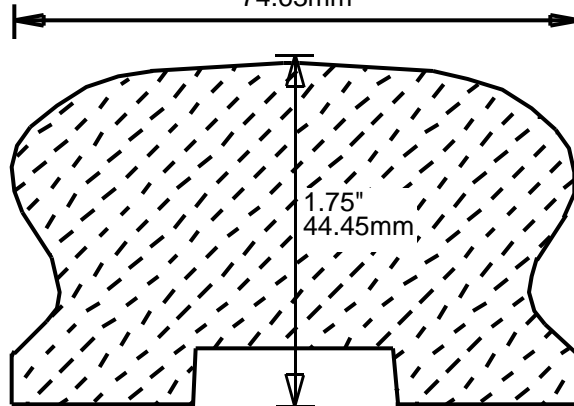

HRP173001

3"  
76.20mm

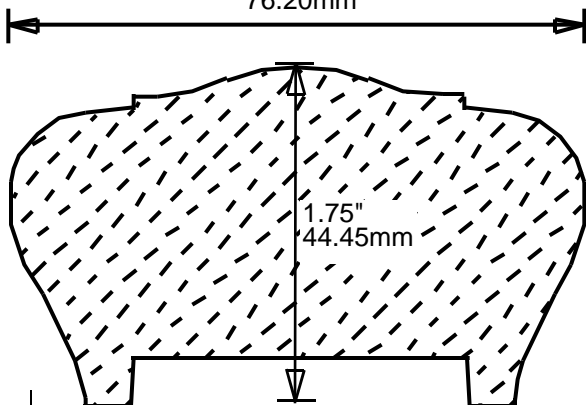

HRP175302

3"  
76.20mm

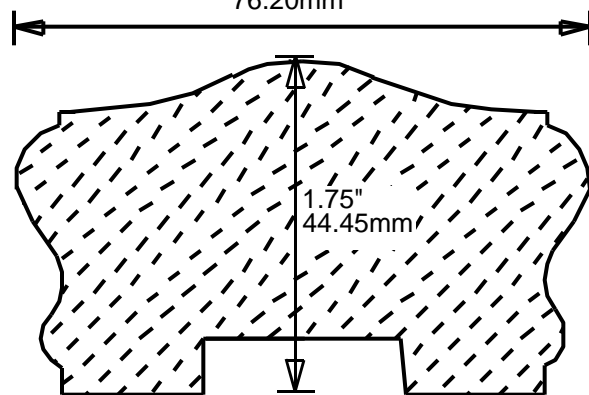

# WEINIG RAIL MOULDING PATTERNS

## HAND RAILS

HRP175501  
5.5"  
139.70mm

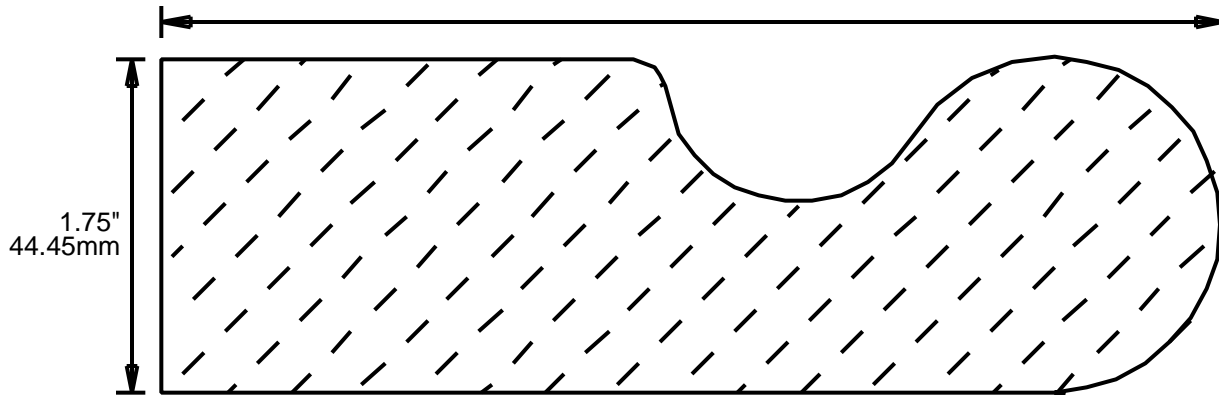

HRP182200  
2.25"  
57.15mm

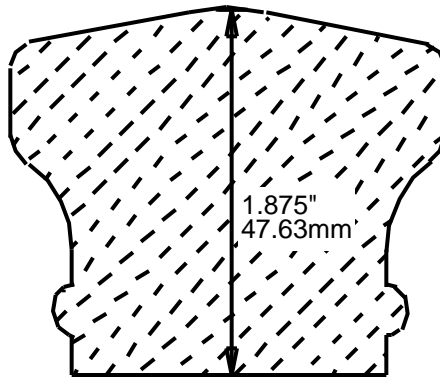

HRP182801  
2.812"  
71.42mm

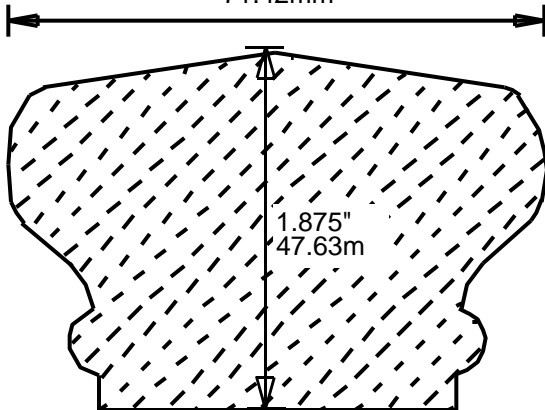

HRP182802  
2.812"  
71.42mm

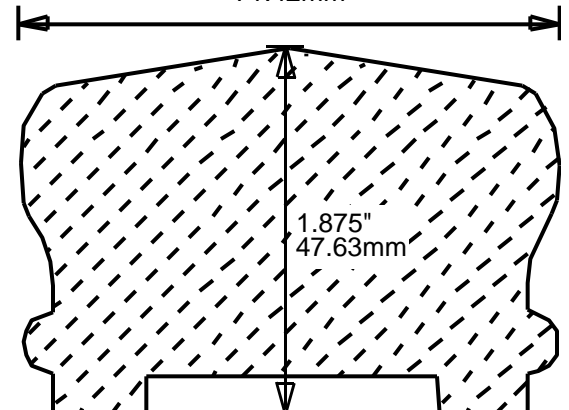

# WEINIG RAIL MOULDING PATTERNS

## HAND RAILS

HRP202700  
2.75"  
69.85mm

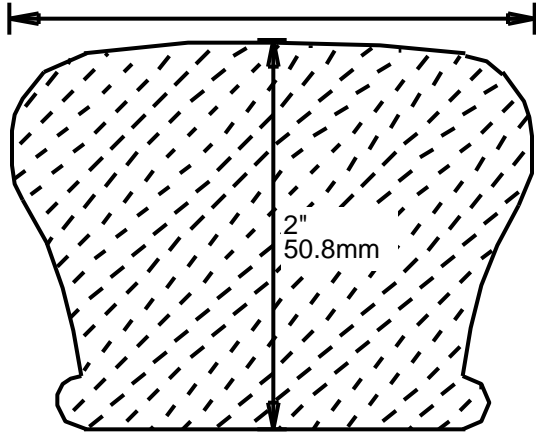

HRP203201  
3.25"  
82.55mm

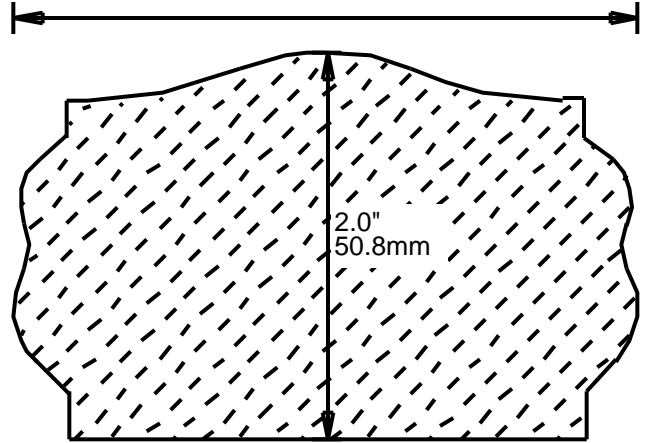

HRP222600  
2.625"  
66.68mm

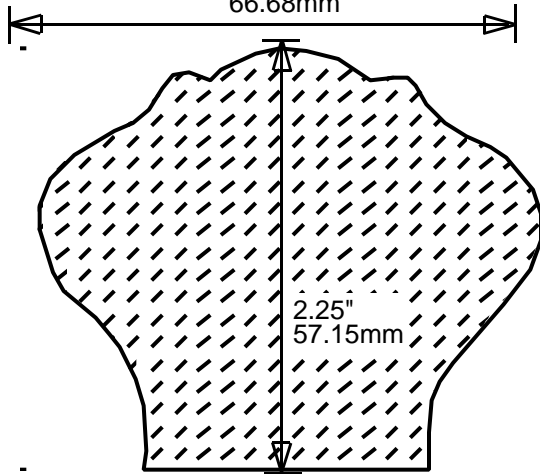

HRP222601  
2.625"  
66.68mm

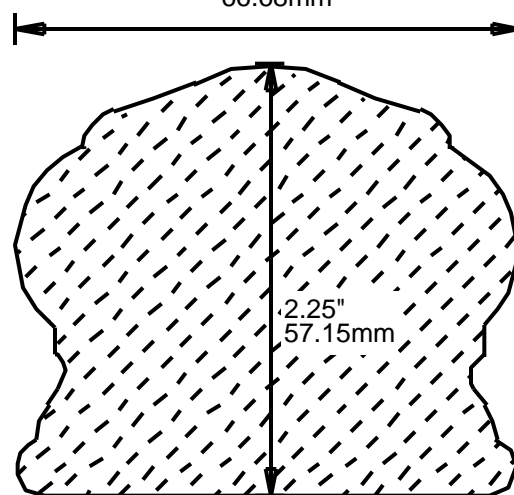

HRP223201  
3.25"  
82.55mm

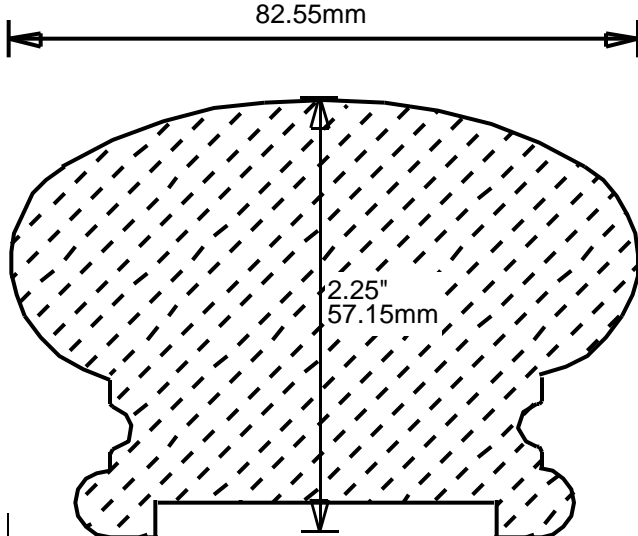

HRP223701  
3.75"  
95.25mm

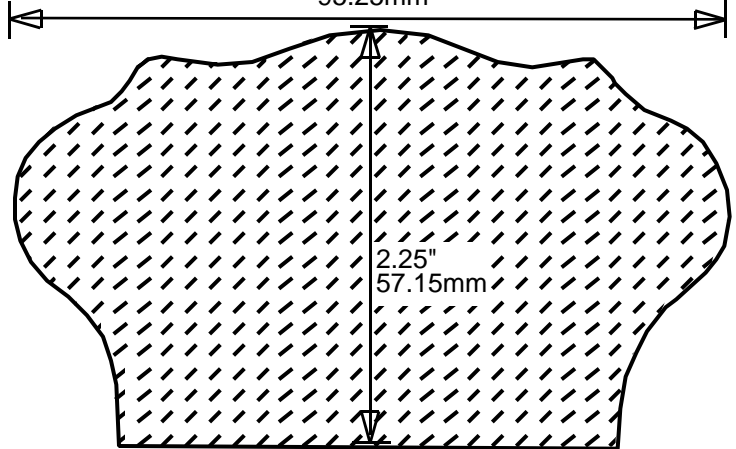



# WEINIG RAIL MOULDING PATTERNS HAND RAILS

HRP224500  
4.856"  
123.34mm

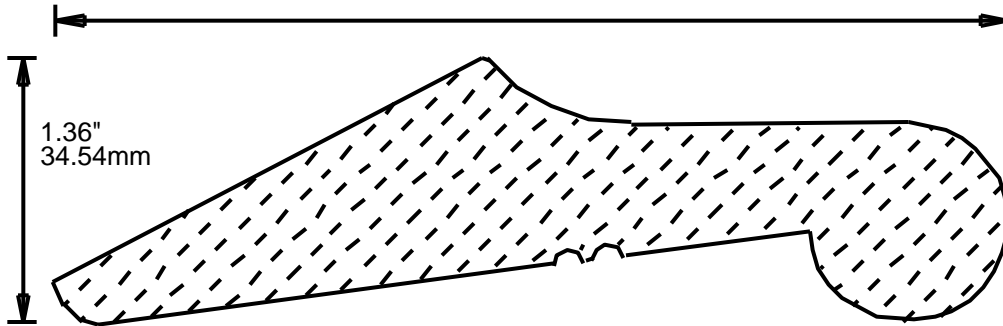

HRP232200  
2.25"  
57.15mm



HRP232201  
2.25"  
57.15mm

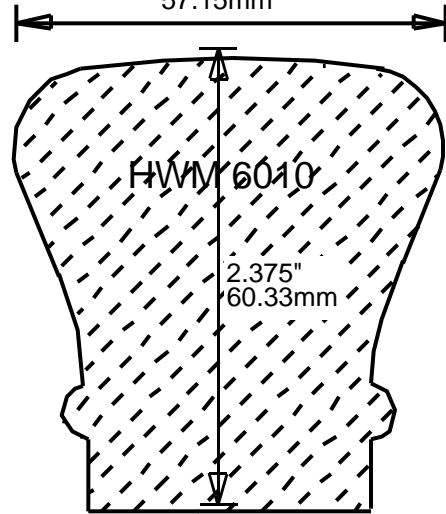

HRP232202  
2.25"  
57.15mm

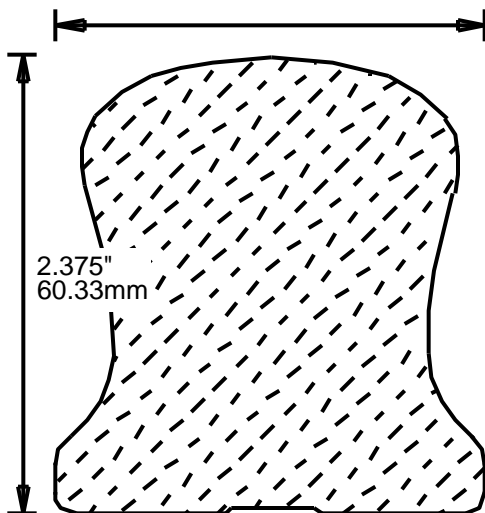

HRP232203  
2.25"  
57.15mm

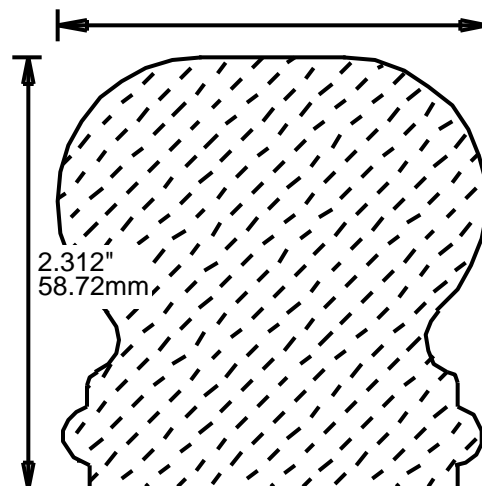

# WEINIG RAIL MOULDING PATTERNS

## HAND RAILS

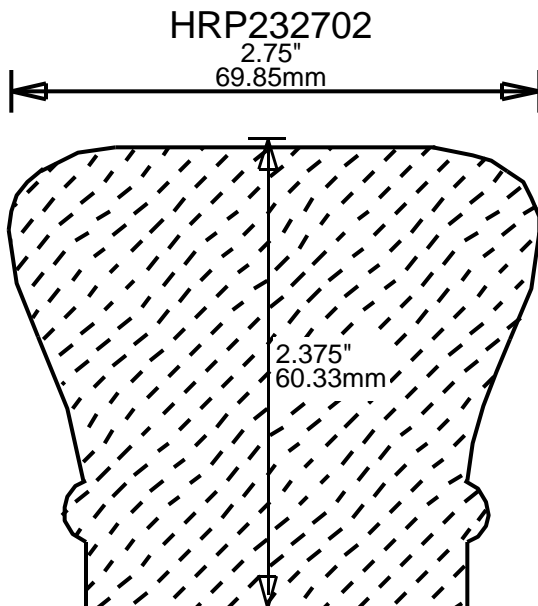
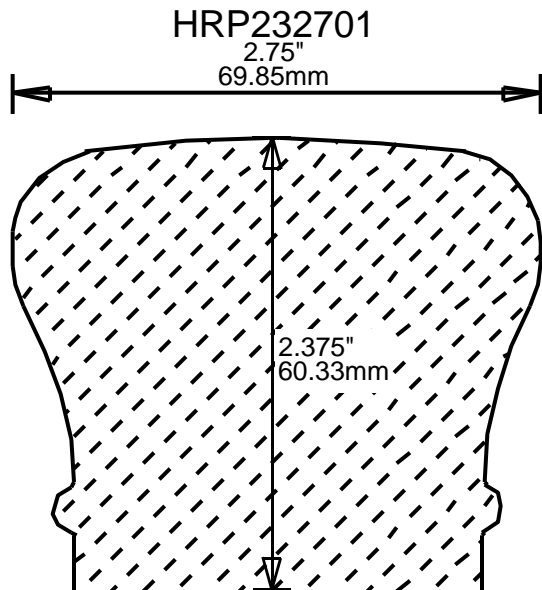
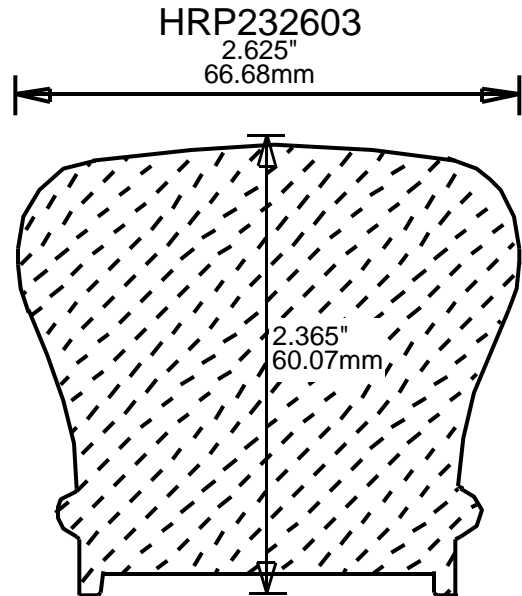
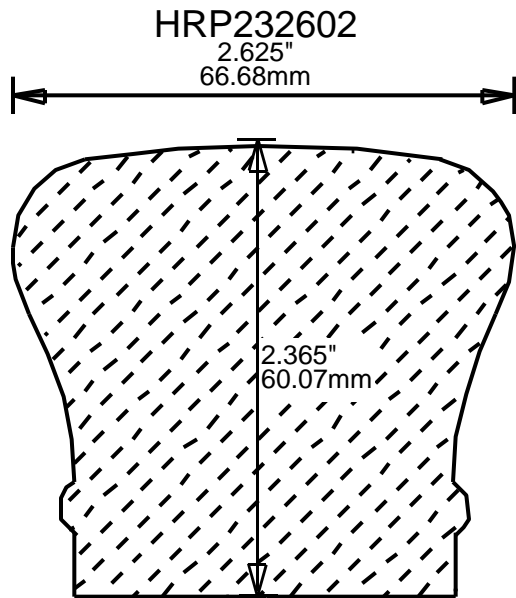
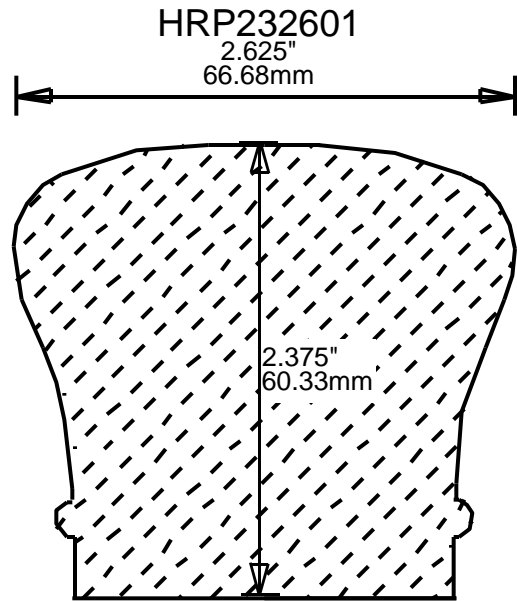
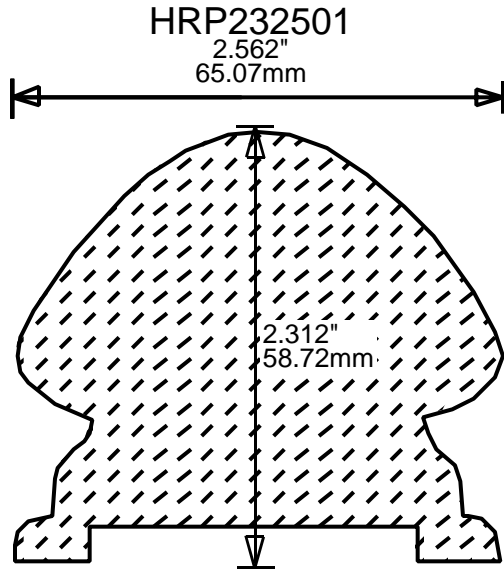

# WEINIG RAIL MOULDING PATTERNS HAND RAILS

HRP233001

3"  
76.20mm

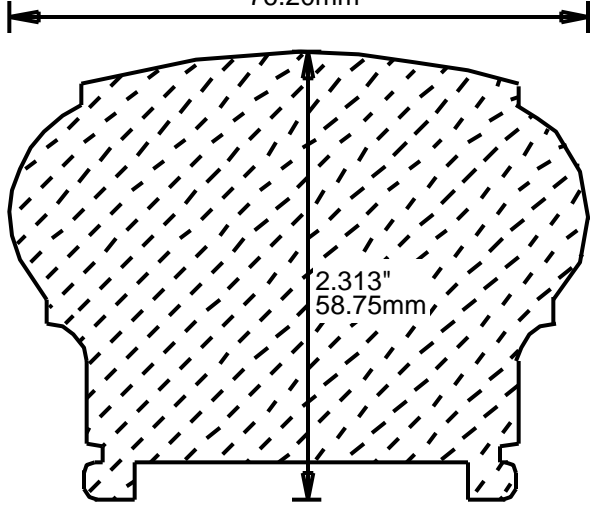

HRP233101

3.125"  
79.38mm

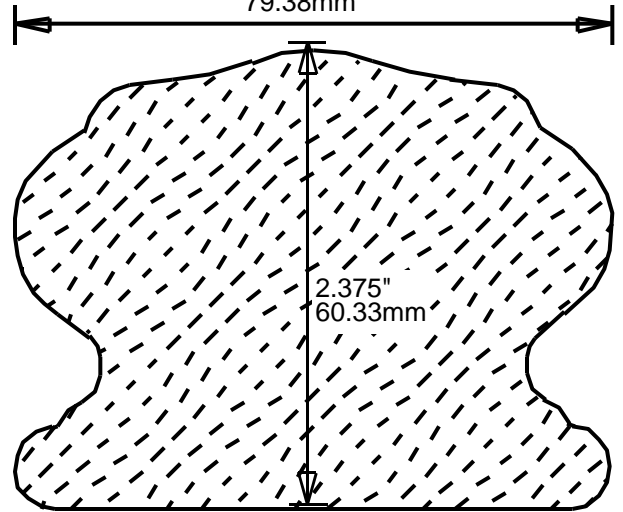

HRP242201

2.25"  
57.15mm

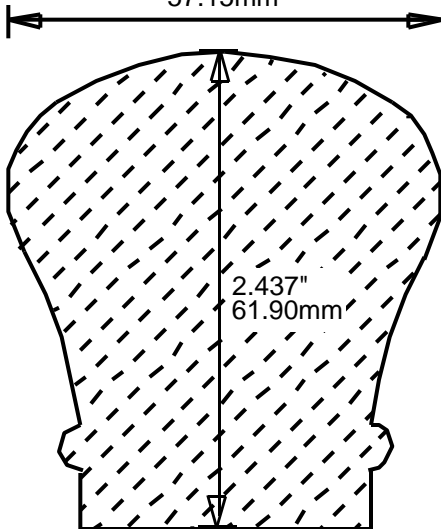

HRP242701

2.75"  
69.85mm

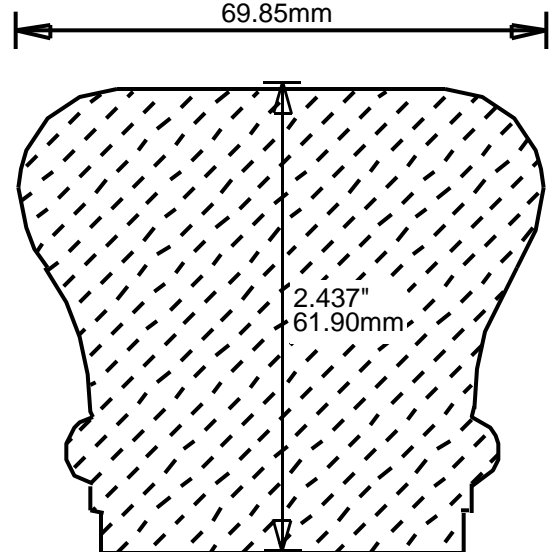

HRP243001

3"  
76.20mm

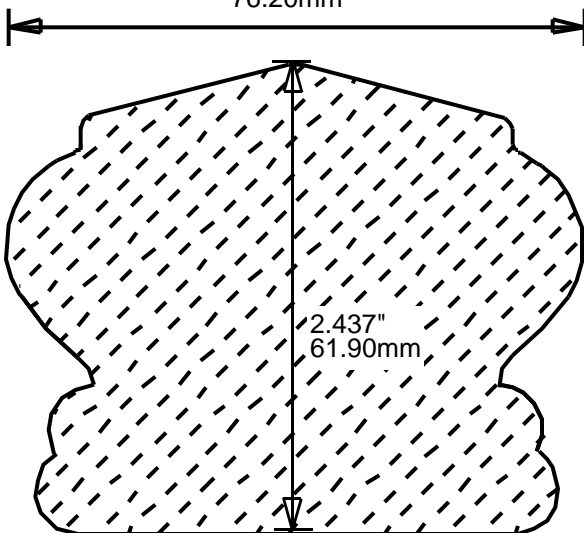

HRP253001

3"  
76.20mm

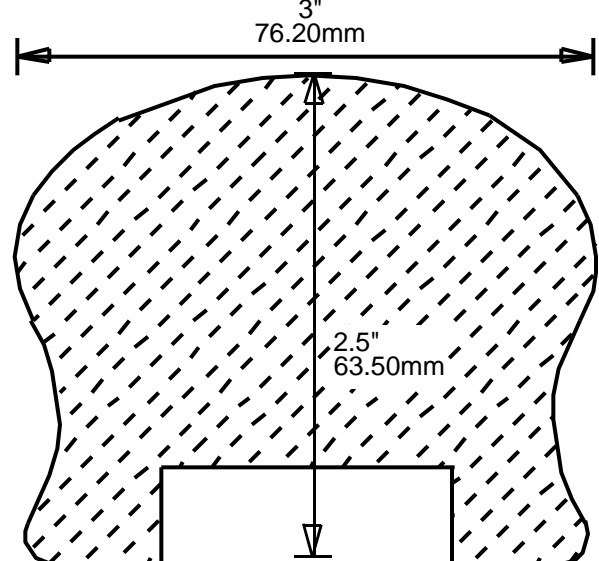

# WEINIG RAIL MOULDING PATTERNS

## HAND RAILS

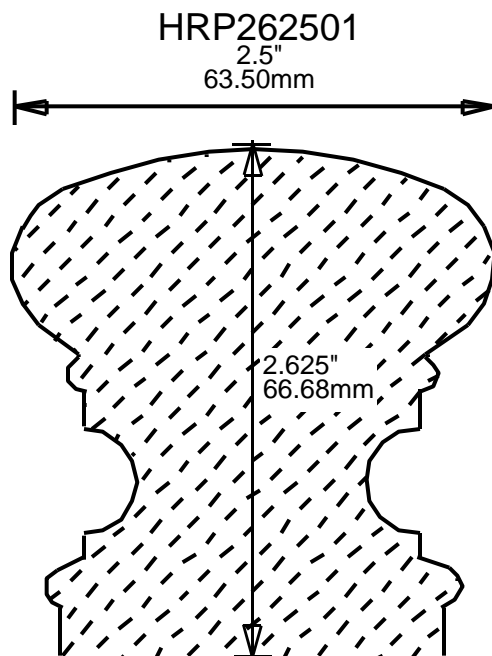
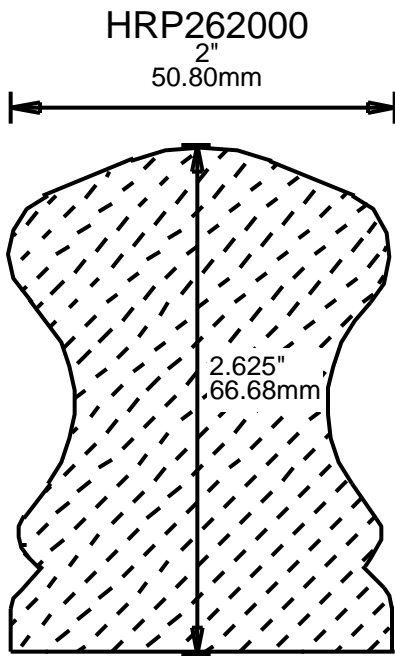
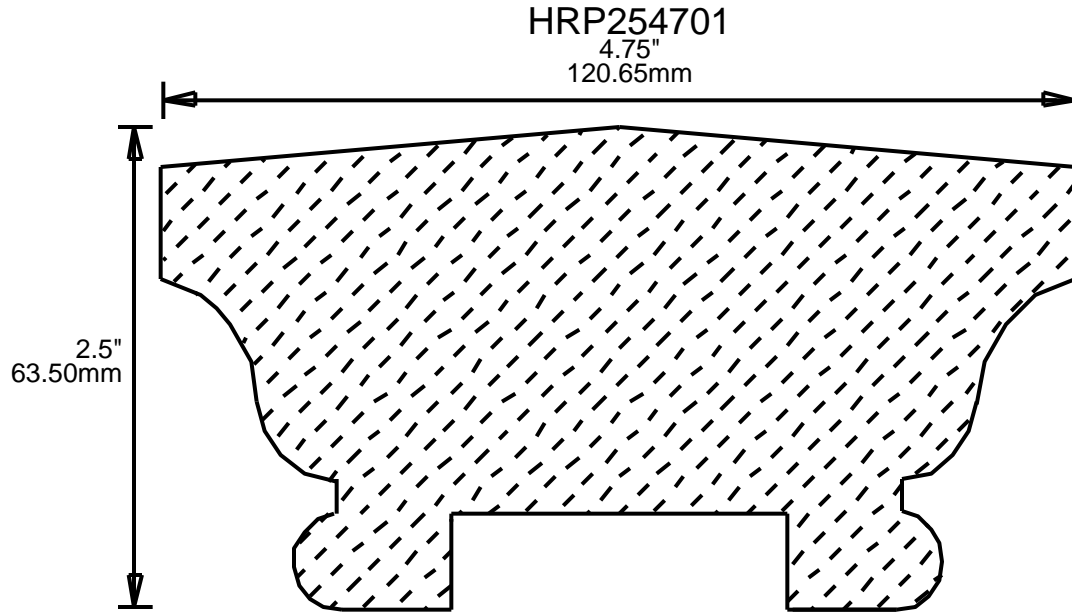

# WEINIG RAIL MOULDING PATTERNS

## HAND RAILS

HRP262601

2.625"  
66.68mm

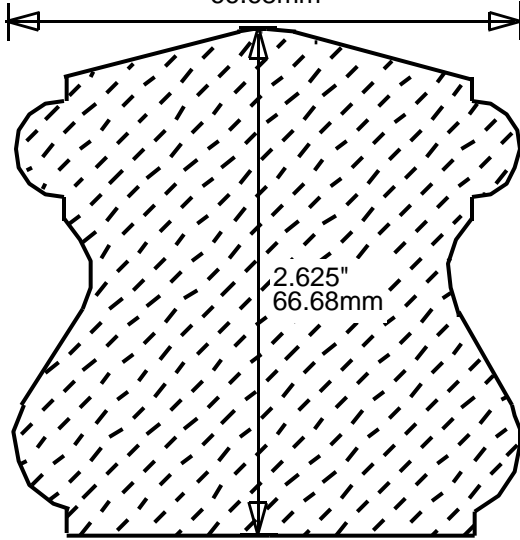

HRP271501

2"  
50.80mm

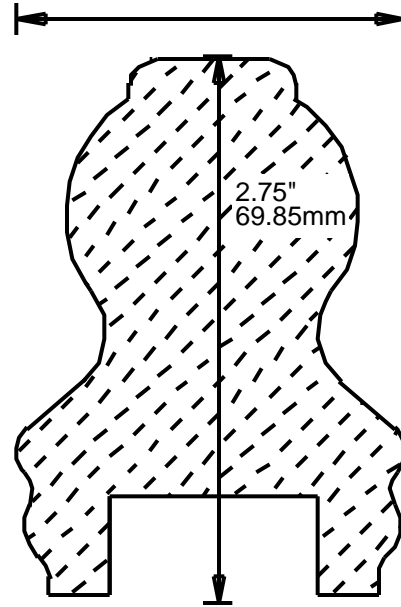

HRP272400

2.437"  
61.90mm

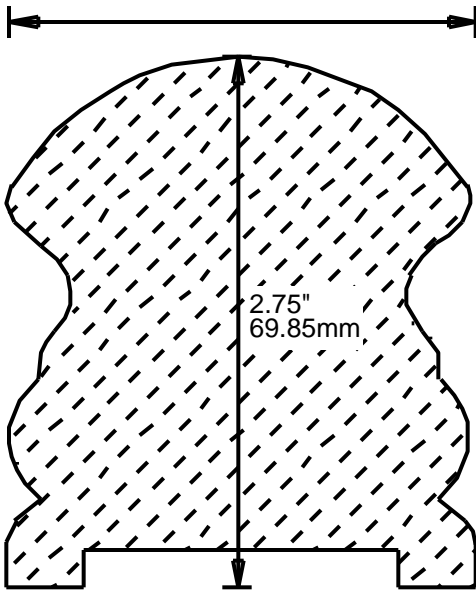

HRP272401

2.437"  
61.90mm

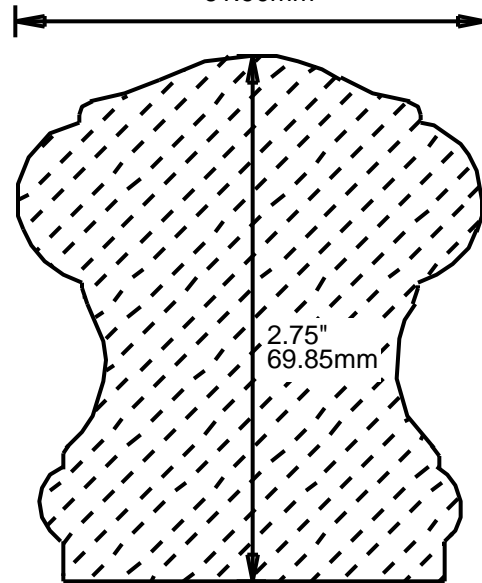

# WEINIG RAIL MOULDING PATTERNS

## HAND RAILS

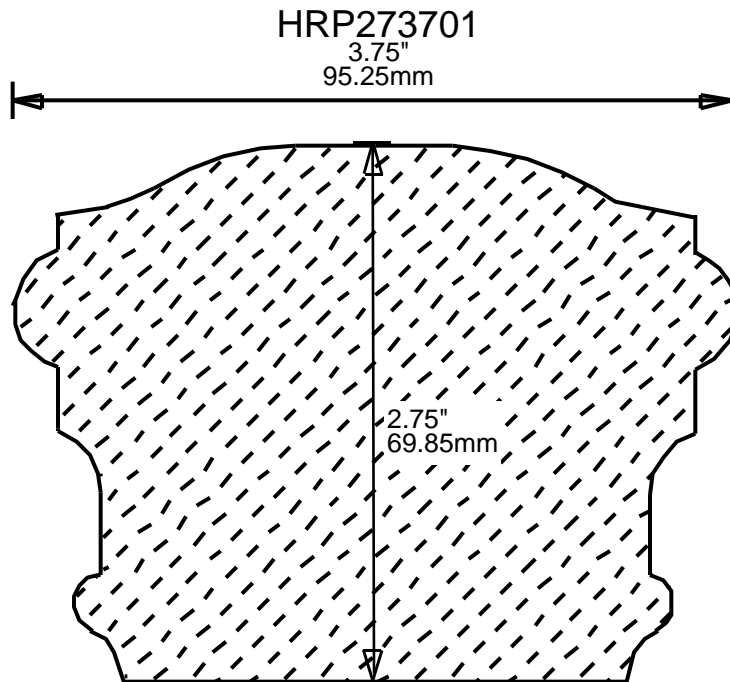
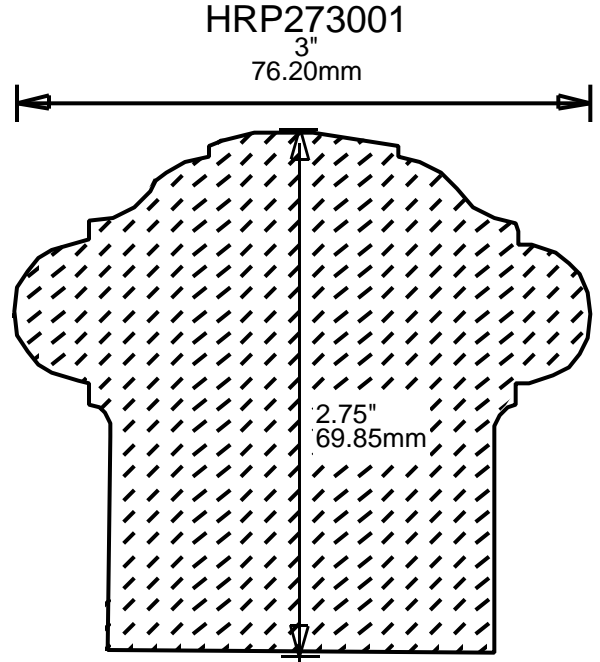
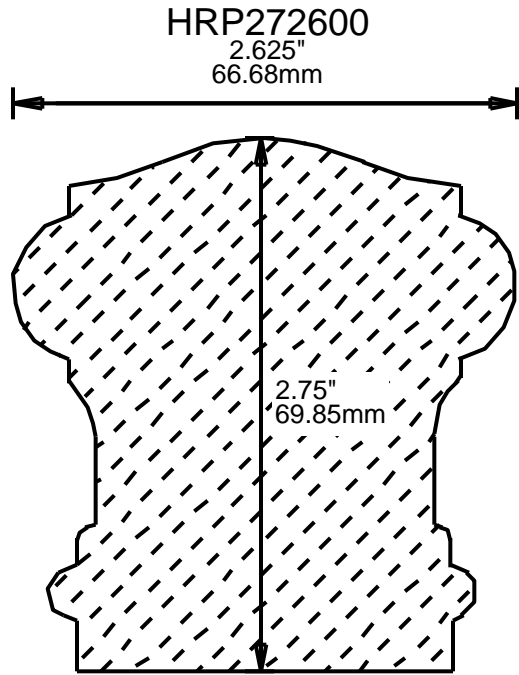

# WEINIG RAIL MOULDING PATTERNS HAND RAILS

HRP274301

4.375"  
111.13mm

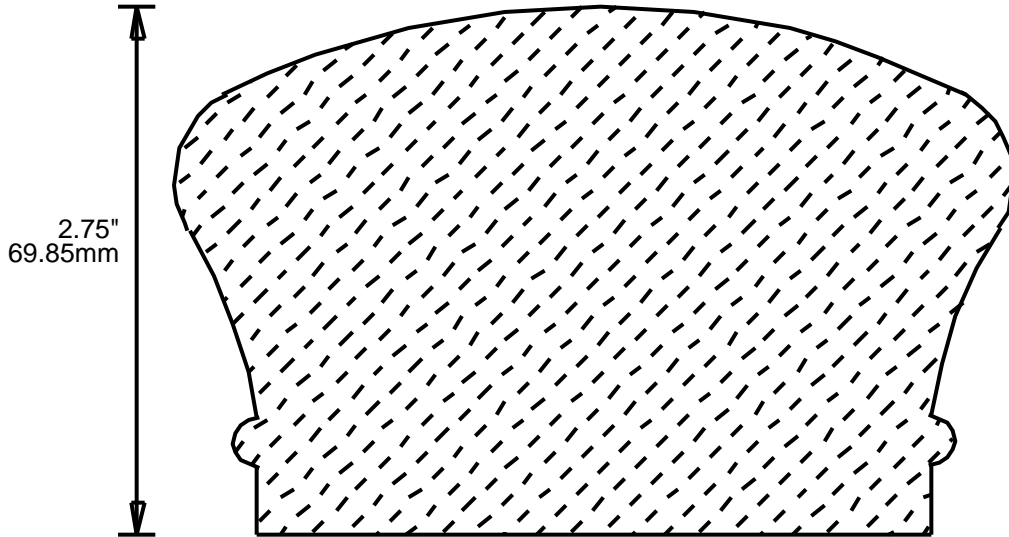

HRP301601

1.625"  
41.28mm

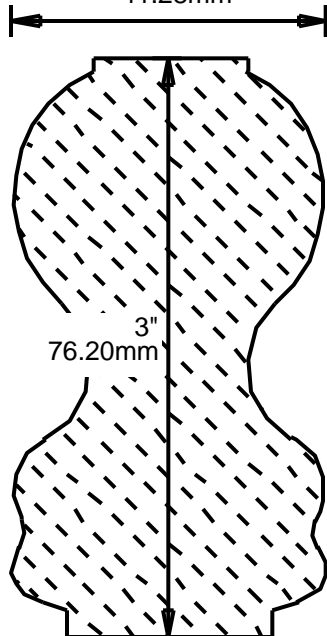

HRP302201

2.25"  
57.15mm

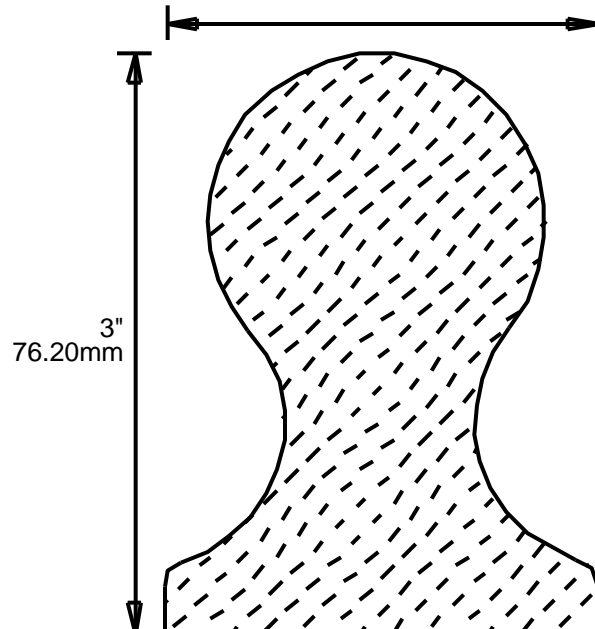

# WEINIG RAIL MOULDING PATTERNS

## HAND RAILS

HRP302501

2.5"  
63.50mm

3"  
76.20mm

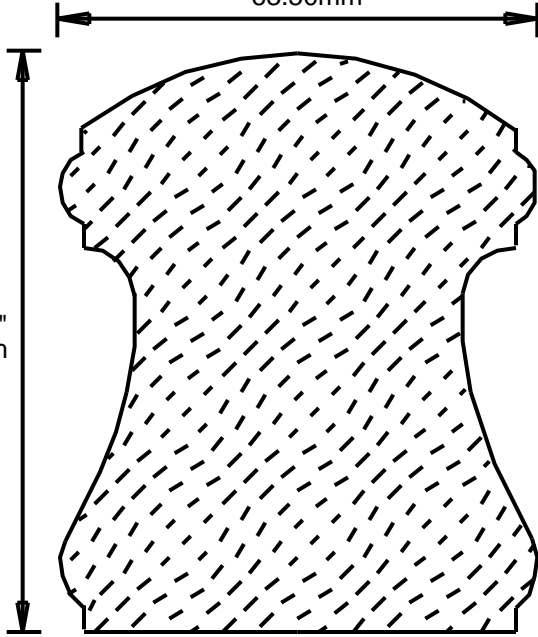

HRP302601

2.625"  
66.68mm

3"  
76.20mm

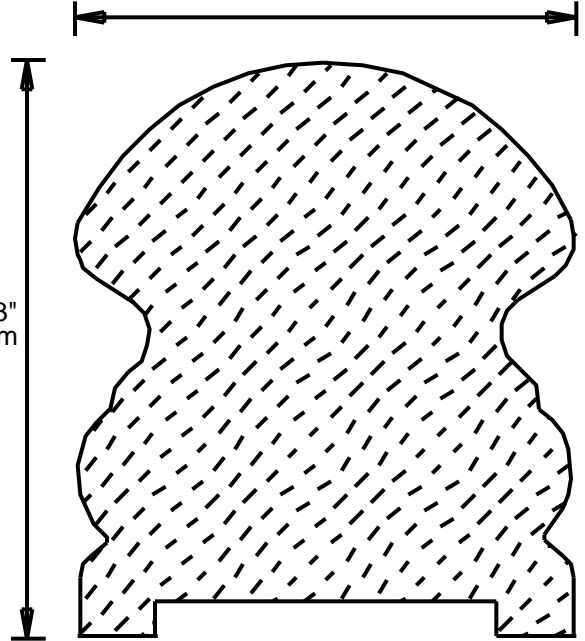

HRP302701

2.75"  
69.85mm

3"  
76.20mm

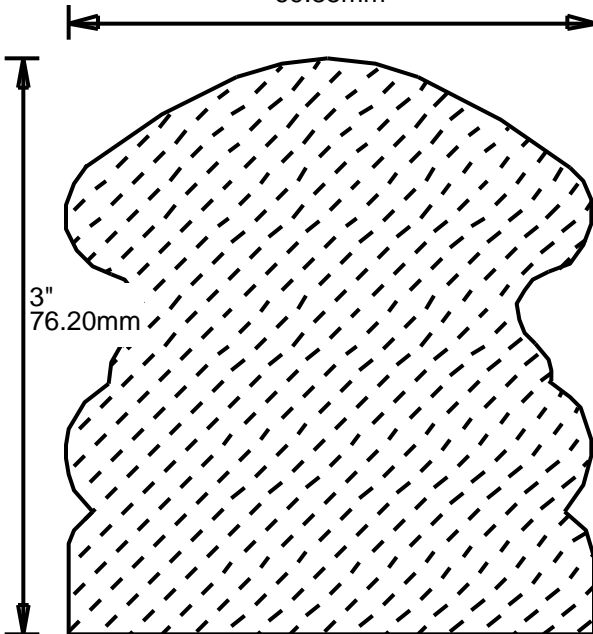

HRP303001

3"  
76.20mm

3"  
76.20mm

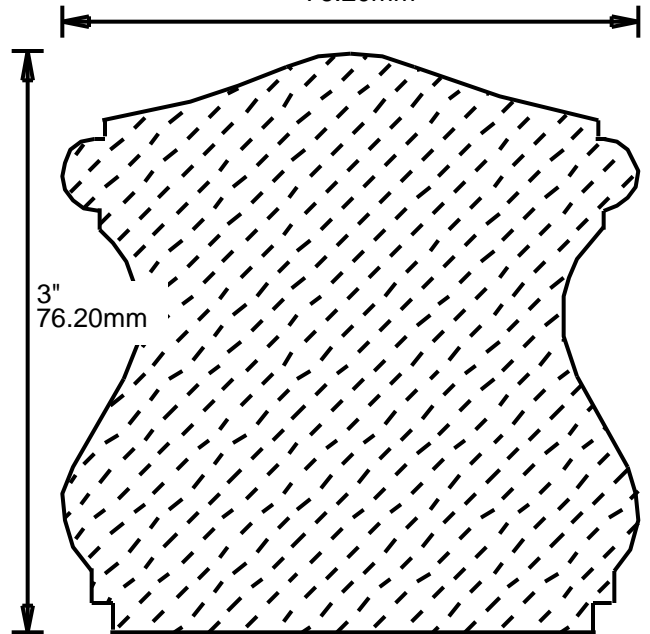



# WEINIG RAIL MOULDING PATTERNS HAND RAILS

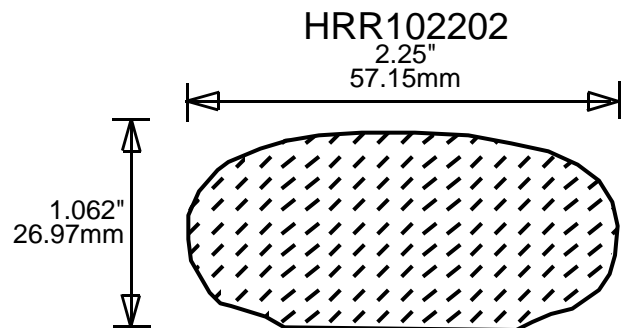
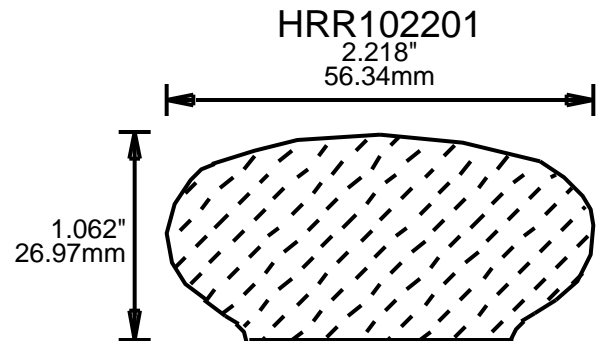
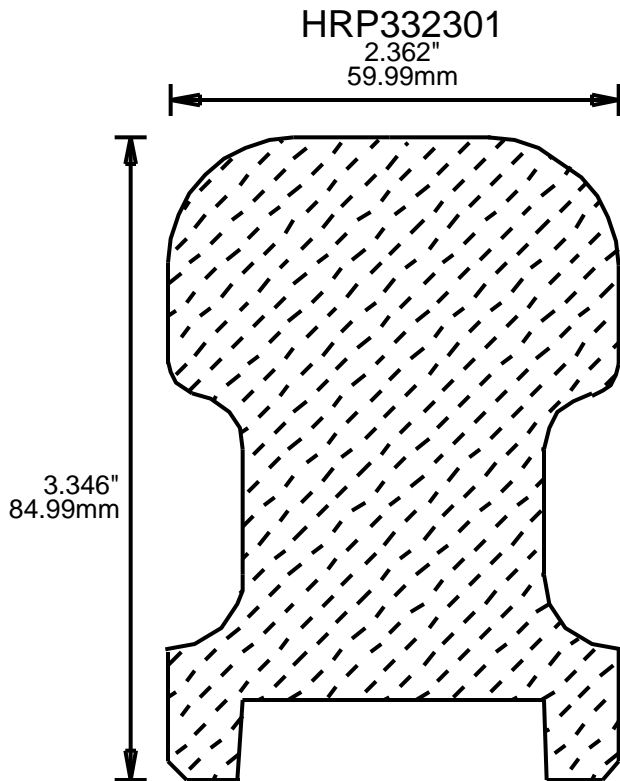
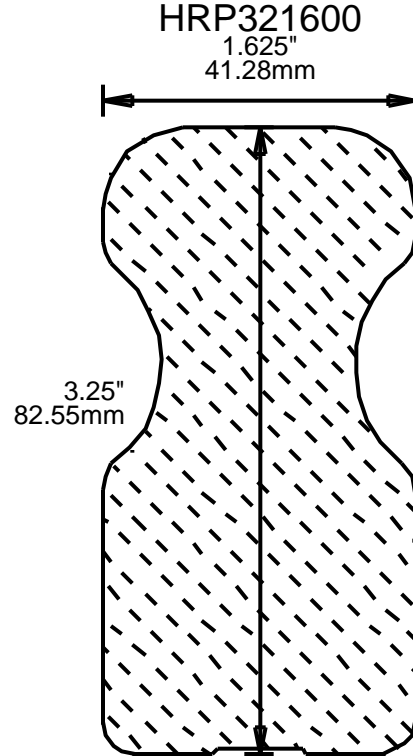
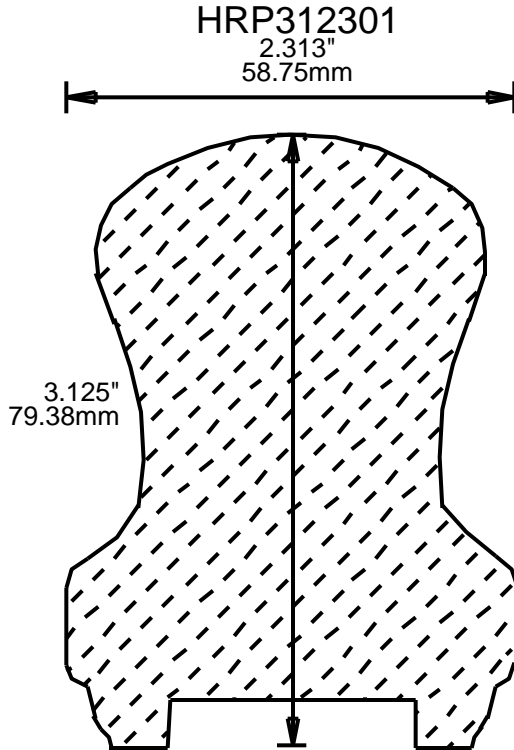

# WEINIG RAIL MOULDING PATTERNS

## HAND RAILS

HRR121501

1.5"  
38.10mm

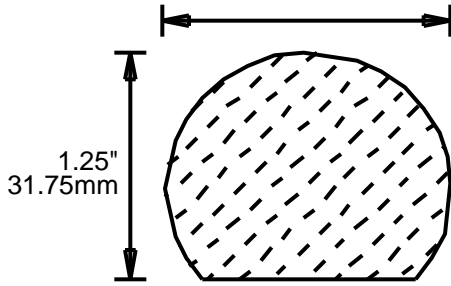

HRR122201

2.25"  
57.15mm

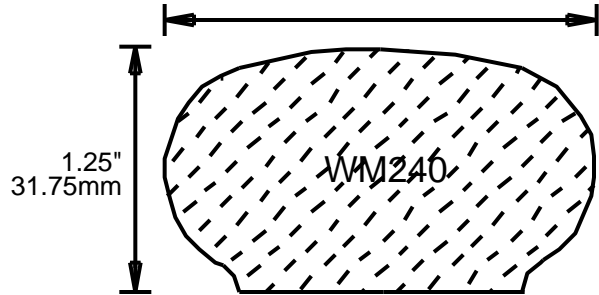

HRR131501

1.5"  
38.10mm

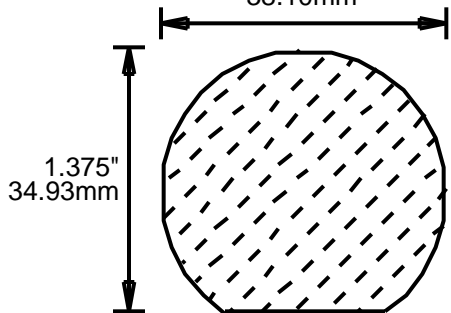

HRR131601

1.625"  
41.28mm

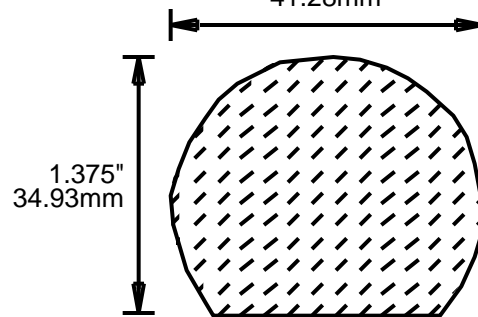

HRR132201

2.25"  
57.15mm

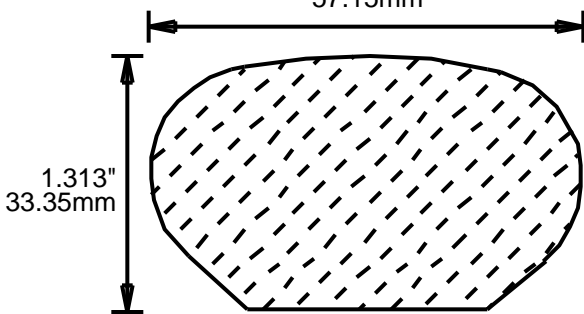

HRR132501

2.5"  
65.07mm

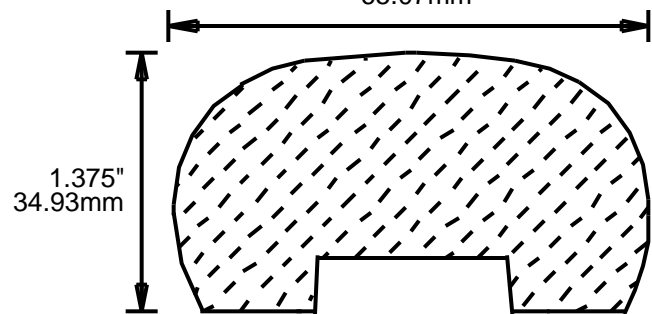

HRR133101

3.125"  
79.38mm

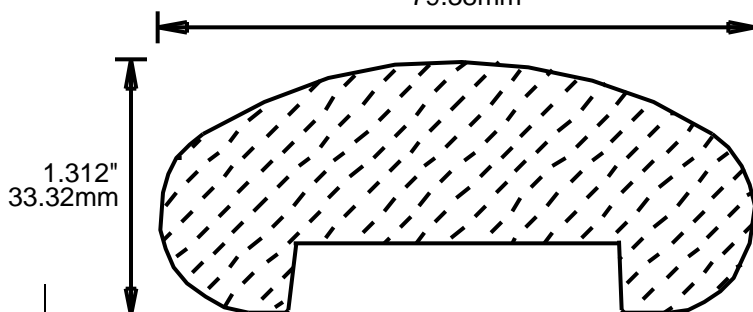

HRR151601

1.687"  
42.85mm

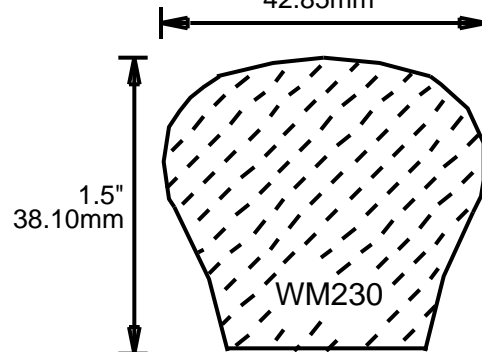

# WEINIG RAIL MOULDING PATTERNS HAND RAILS

HRR151602

1.687"  
42.85mm

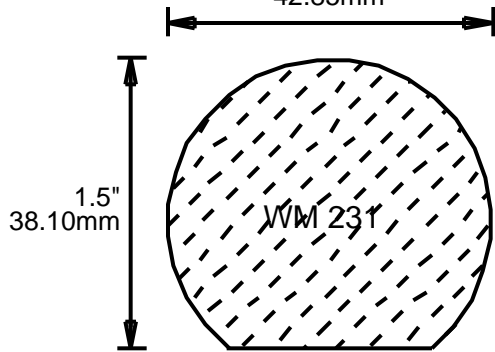

HRR161700

1.75"  
44.45mm

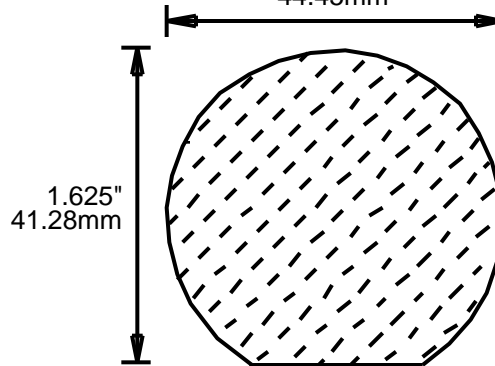

HRR162001

2"  
50.80mm

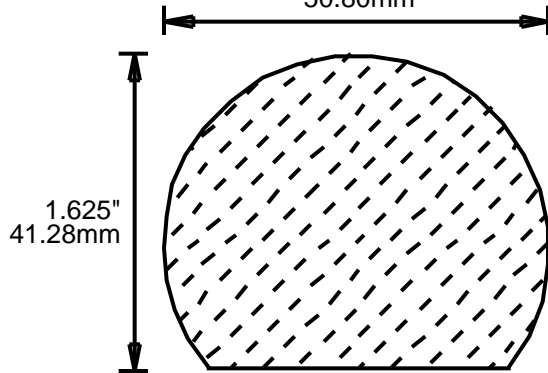

HRR162801

2.875"  
73.03mm

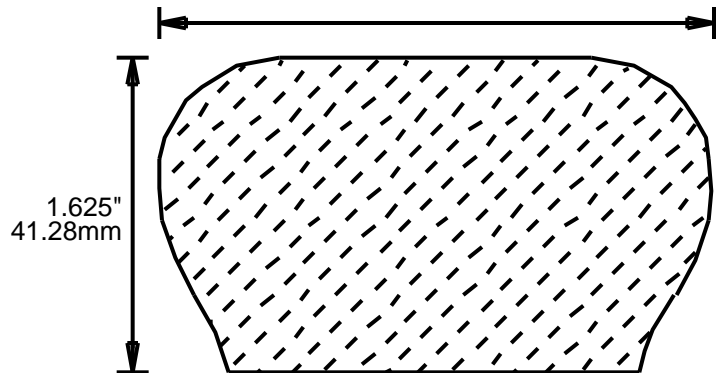

HRR162901

2.937"  
74.60mm

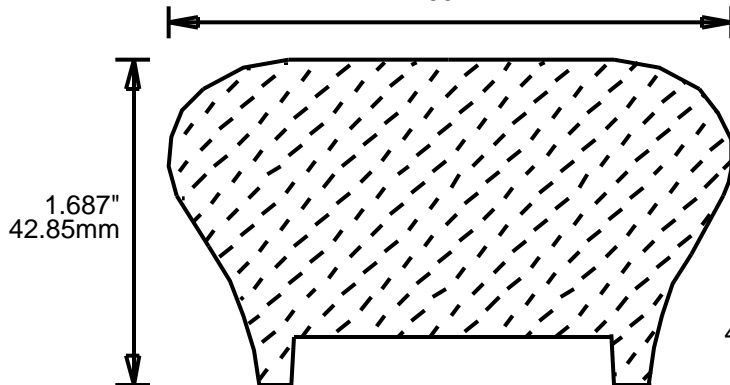

HRR172501

2.5"  
65.07mm

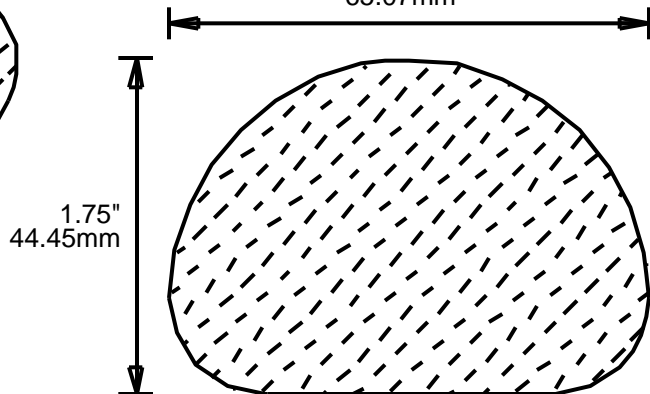

# WEINIG RAIL MOULDING PATTERNS

## HAND RAILS

HRR172701

2.75"  
69.85mm

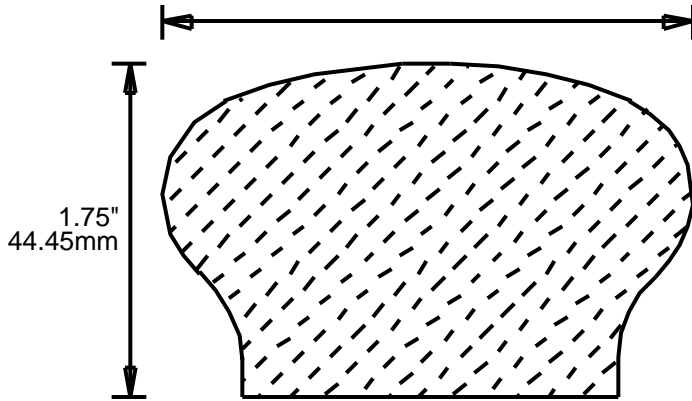

HRR172801

2.813"  
71.45mm

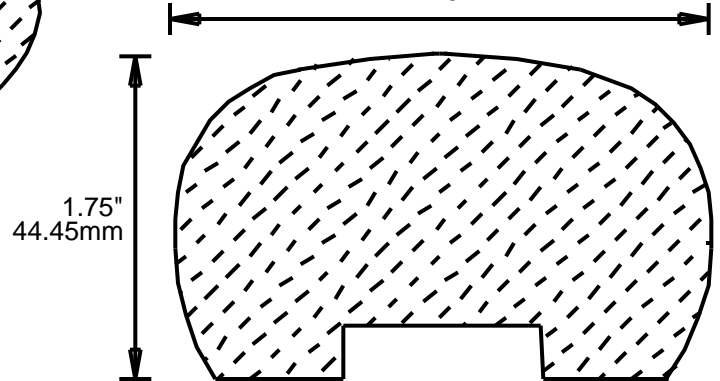

HRR173001

3.5"  
88.90mm

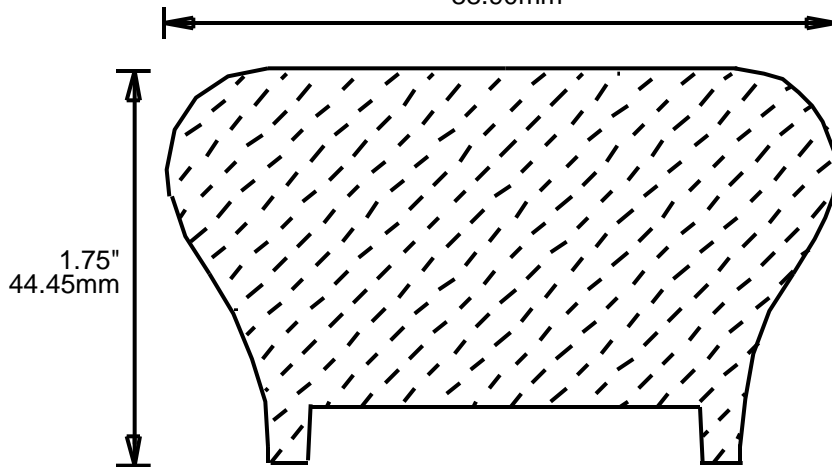

HRR173501

3.5"  
88.90mm

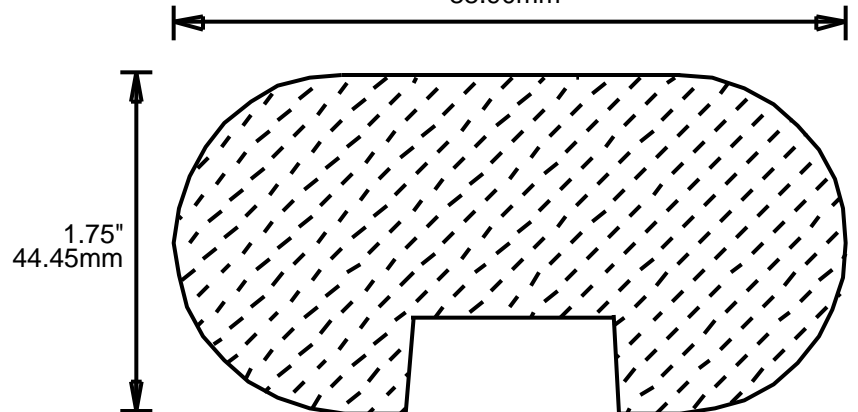

Templates for the panel moulding patterns shown in this book are available through Weinig Custom Grinding Service. Panel mouldings include all base caps, picture mouldings, and back bands.

In addition to these stock templates, Weinig Custom Grinding Service also will make custom-profile panel moulding templates specifically for your needs. Templates can be made using other CAD drawings, a wood sample, a tracing, or only an idea.

## PANEL MOULDING PATTERNS

Panel mouldings are grouped into three categories:

- BC Base caps, which include back bands and panel caps
- PM Panel mouldings
- CM Picture mouldings

[CLICK HERE TO SEE BASE CAPS](#)

[CLICK HERE TO SEE PANEL MOULDINGS](#)

[CLICK HERE TO SEE PICTURE MOULDINGS](#)

# WEINIG PANEL MOULDING PATTERNS

## BASE CAPS

PABC00680

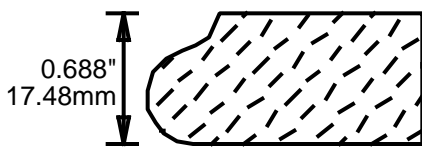

PABC10101

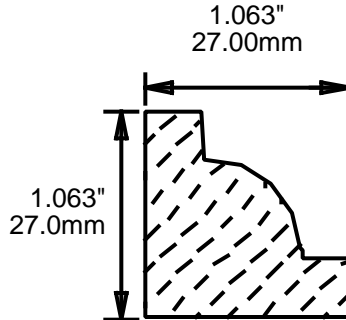

PABC10430

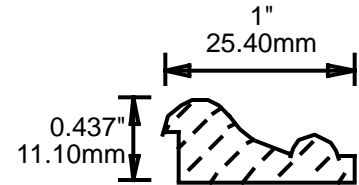

PABC10431

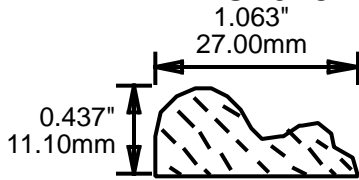

PABC10500

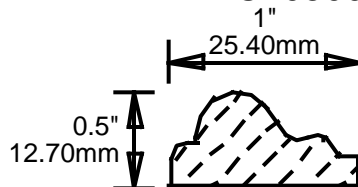

PABC10501

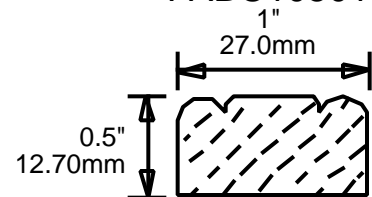

PABC10560

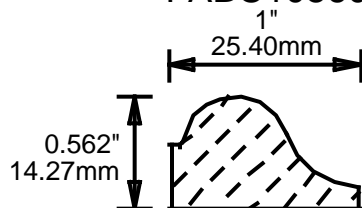

PABC10620

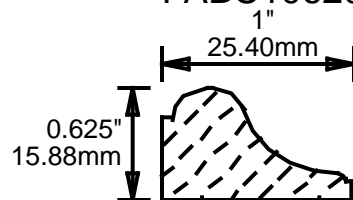

PABC10621

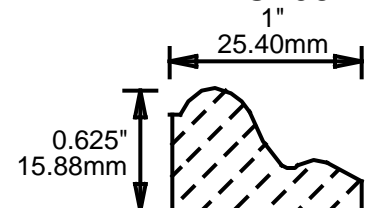

# WEINIG PANEL MOULDING PATTERNS

## BASE CAPS

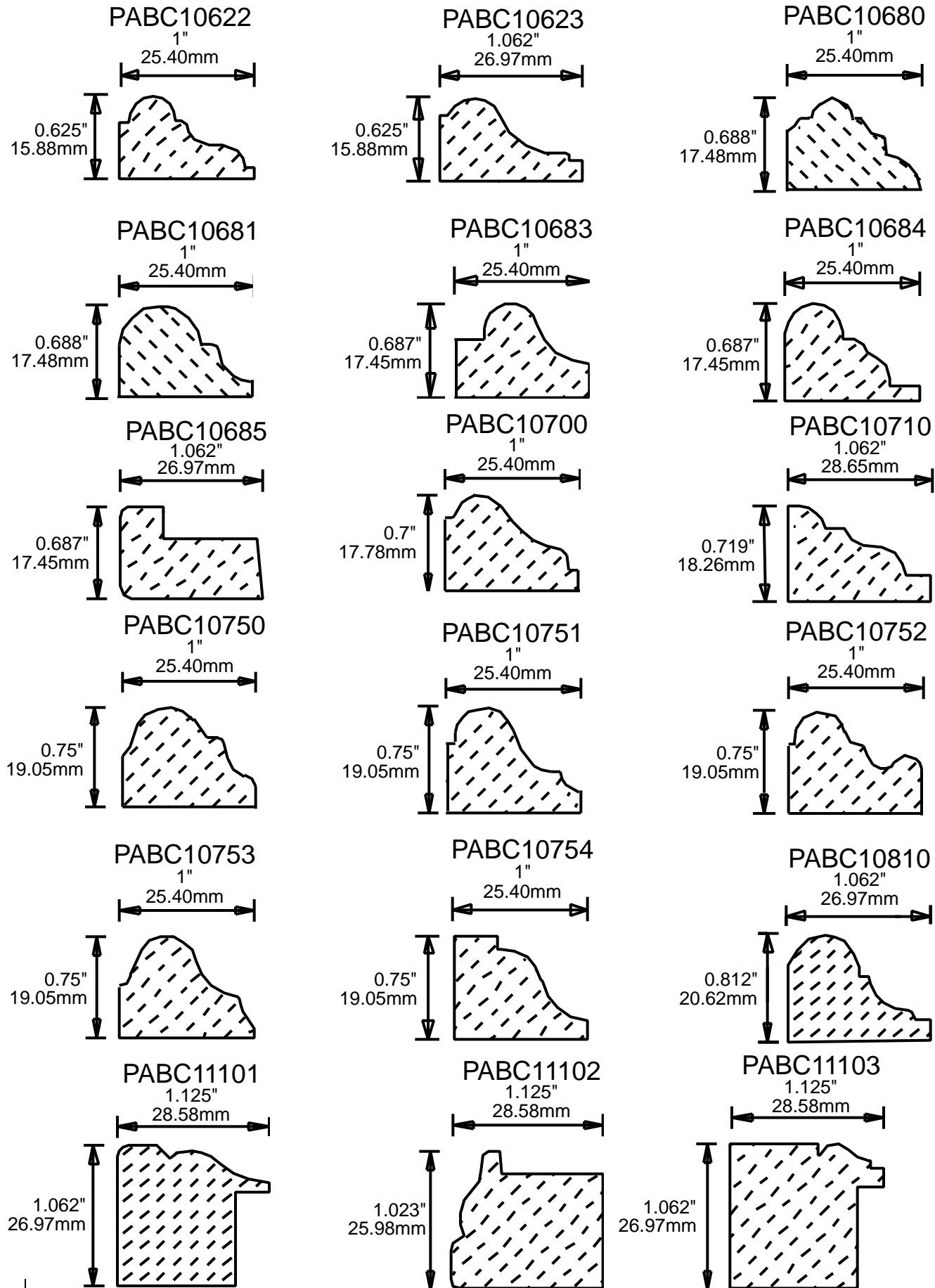

# WEINIG PANEL MOULDING PATTERNS

## BASE CAPS

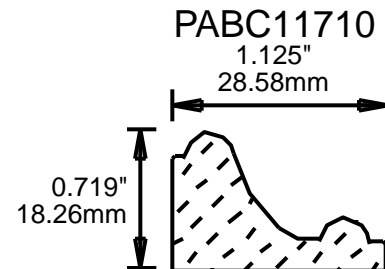
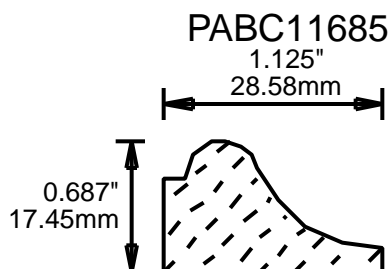
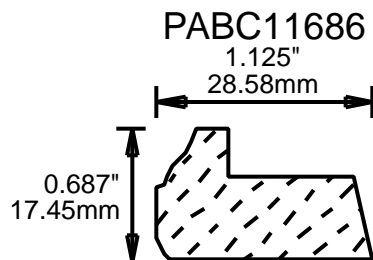
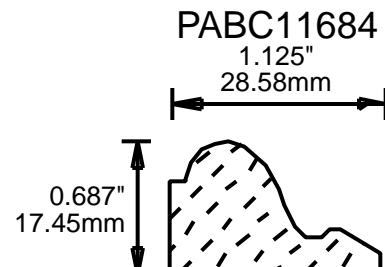
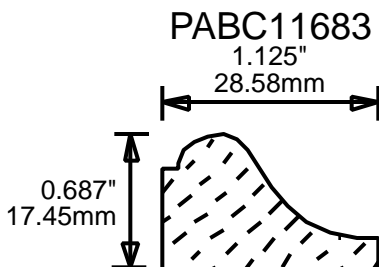
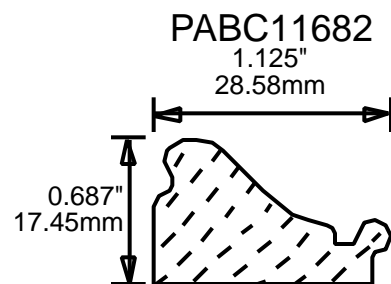
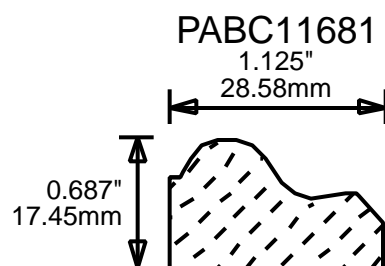
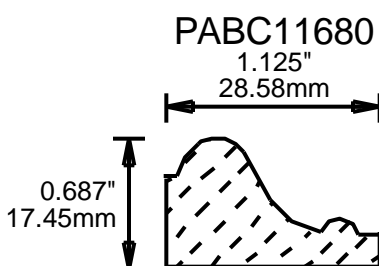
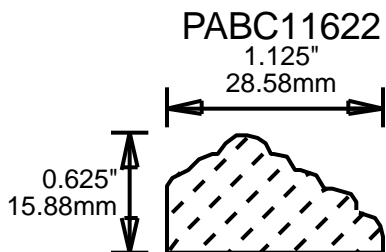
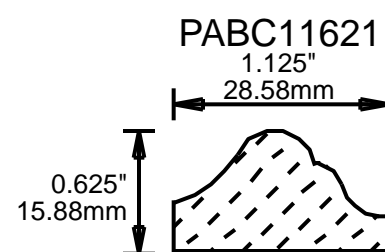
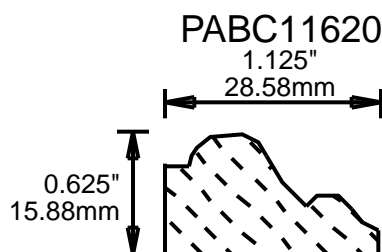
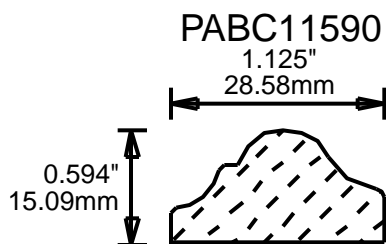
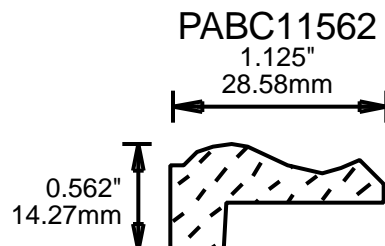
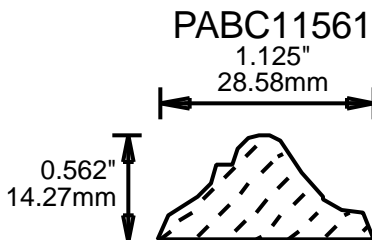
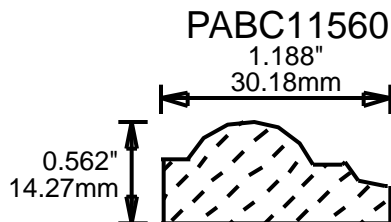
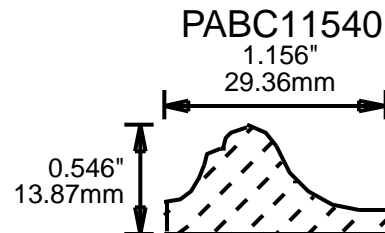
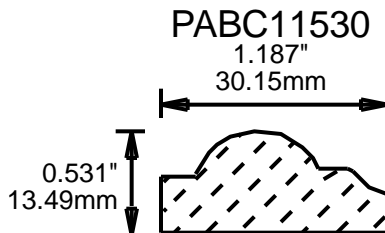
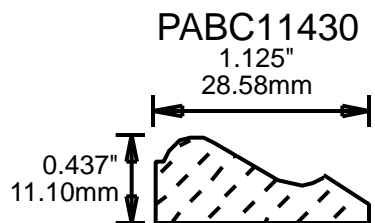



# WEINIG PANEL MOULDING PATTERNS

## BASE CAPS

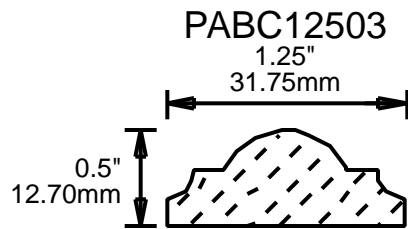
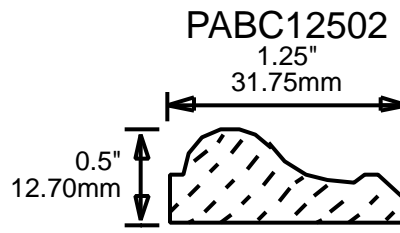
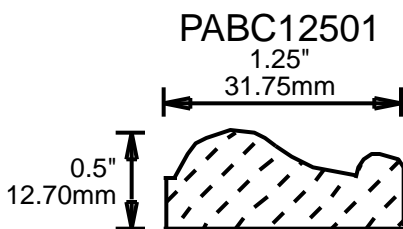
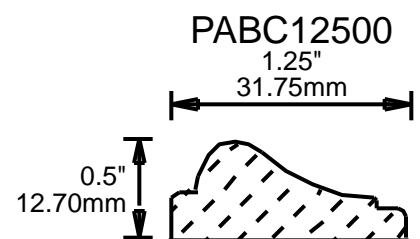
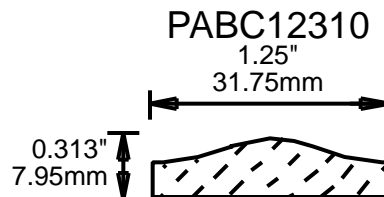
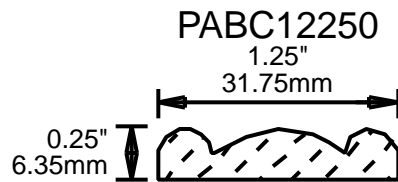
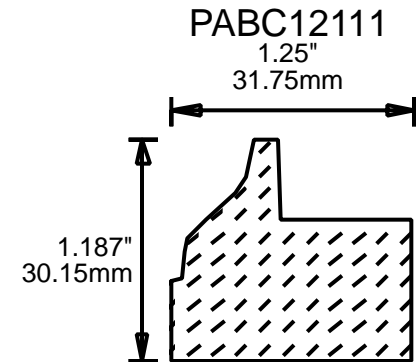
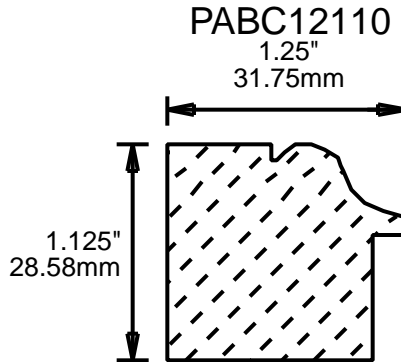
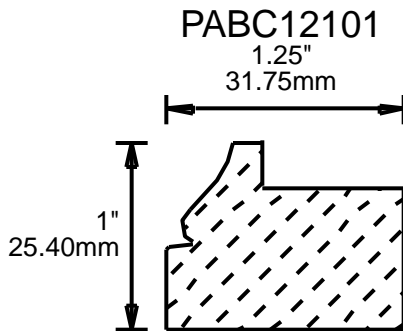
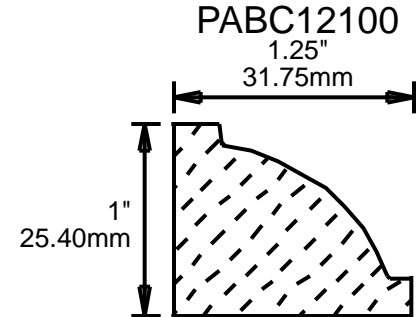
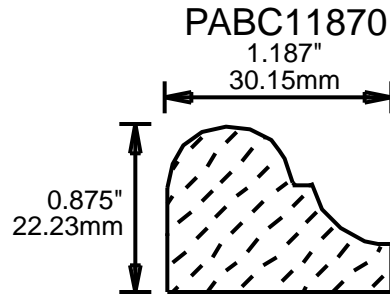
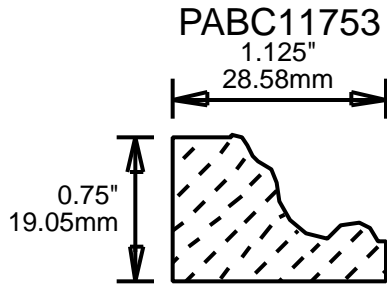
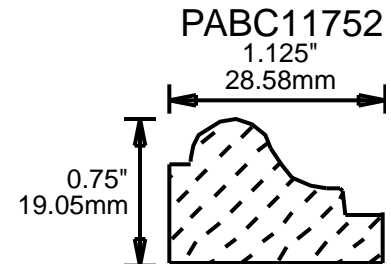
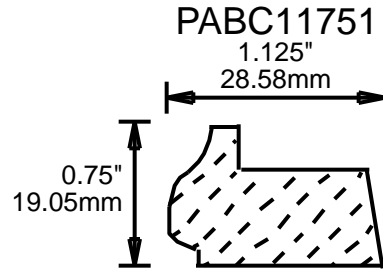
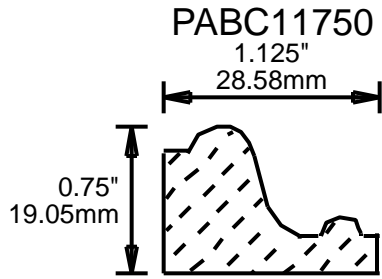

# WEINIG PANEL MOULDING PATTERNS

## BASE CAPS

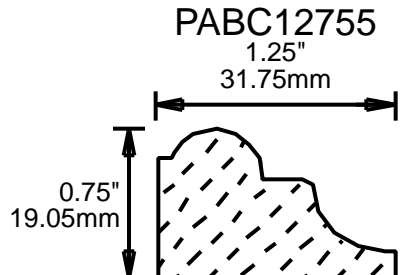
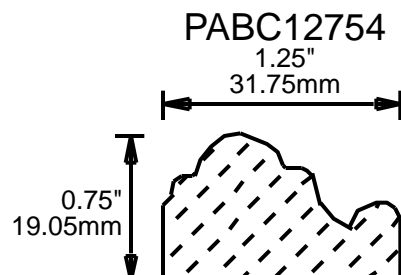
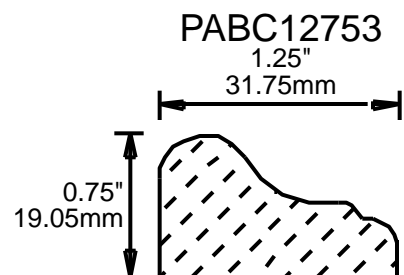
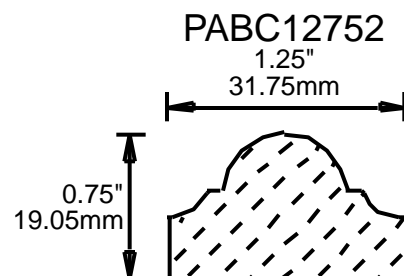
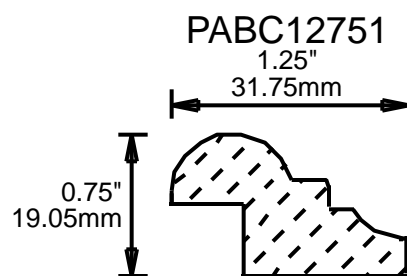
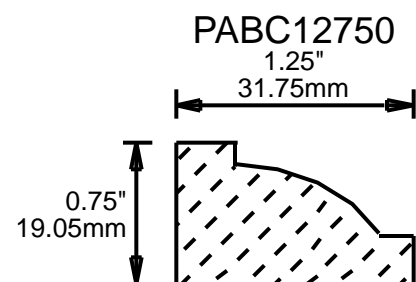
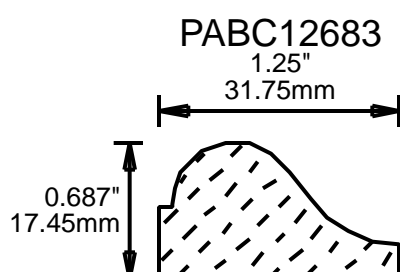
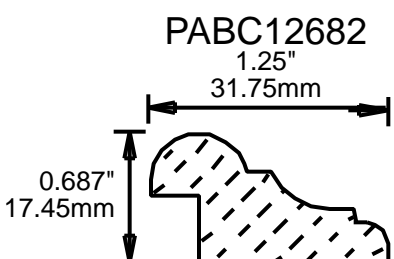
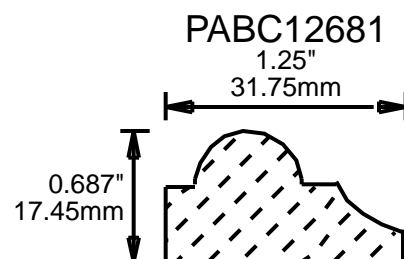
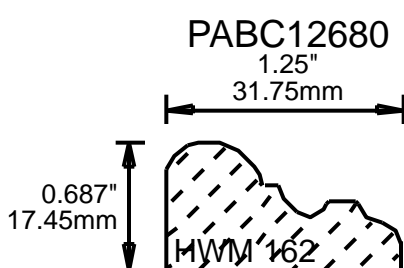
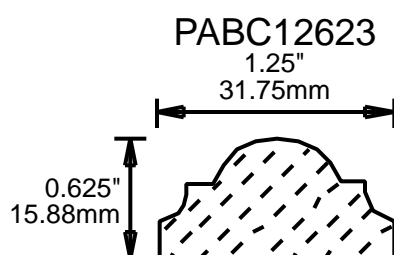
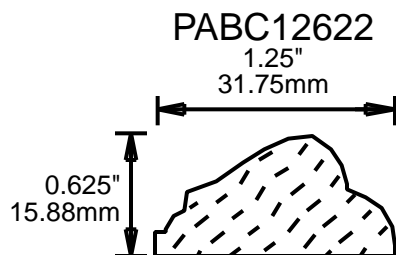
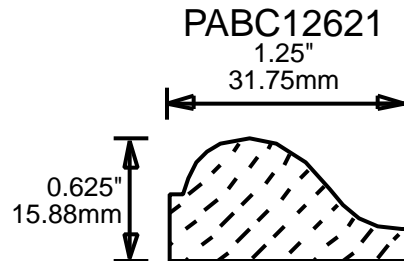
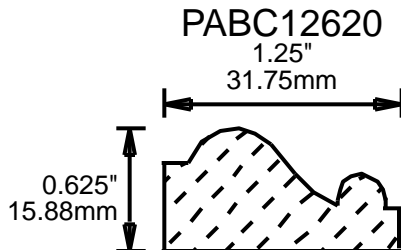
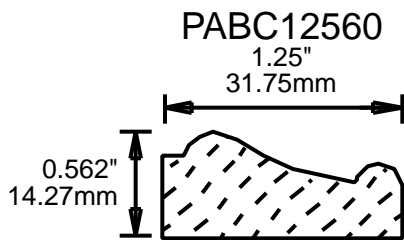

# WEINIG PANEL MOULDING PATTERNS

## BASE CAPS

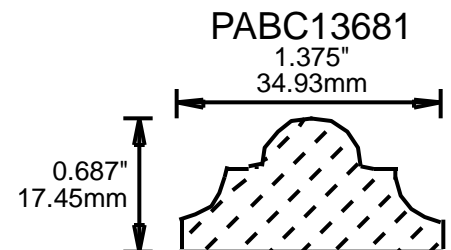
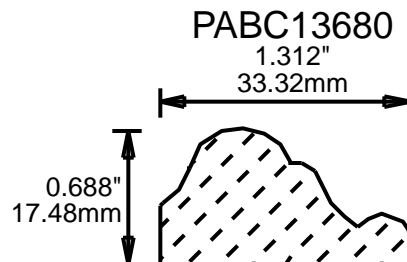
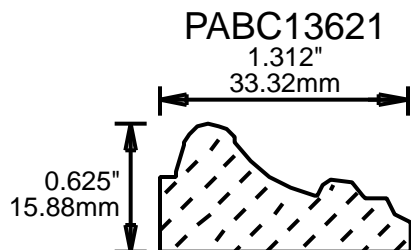
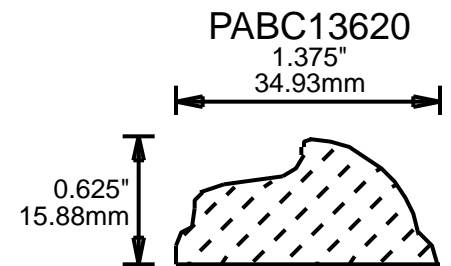
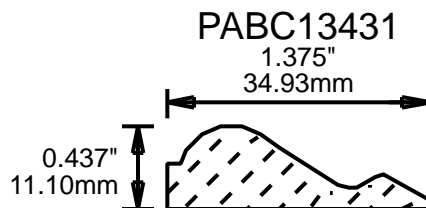
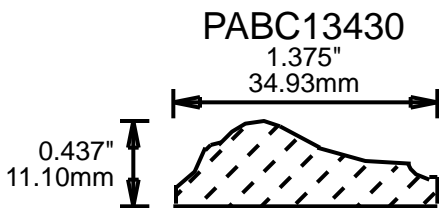
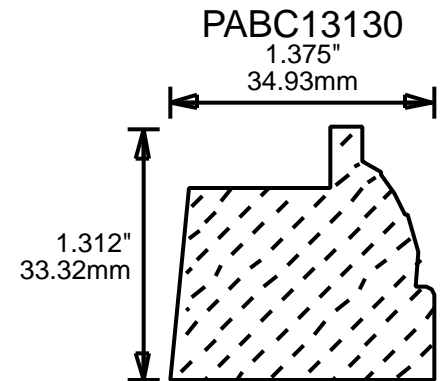
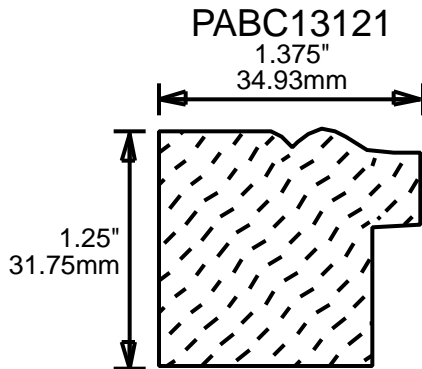
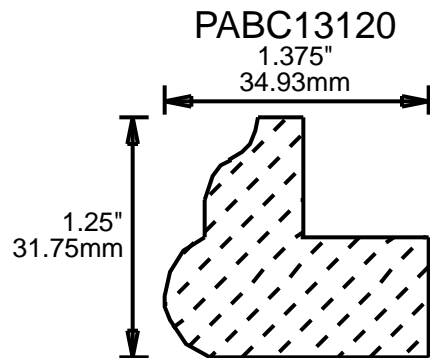
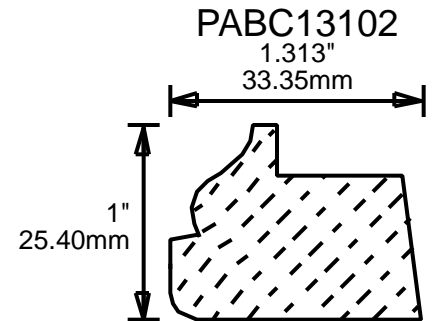
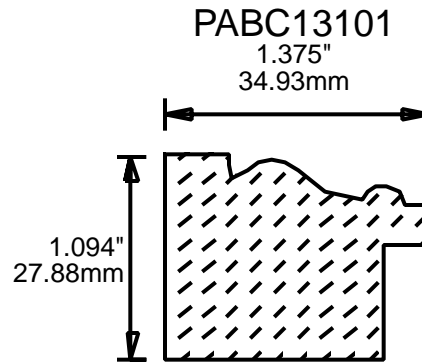
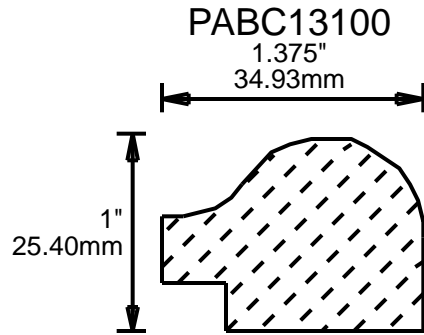
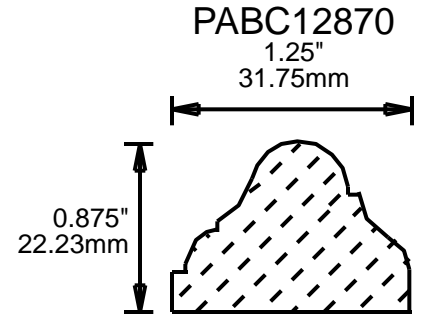
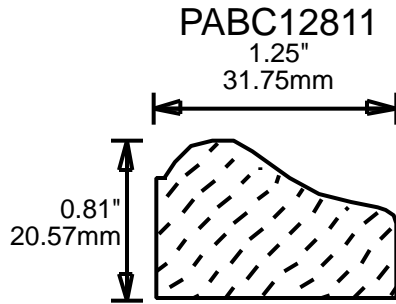
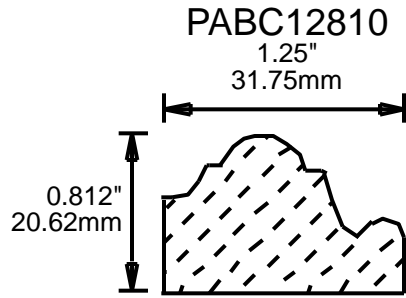

# WEINIG PANEL MOULDING PATTERNS

## BASE CAPS

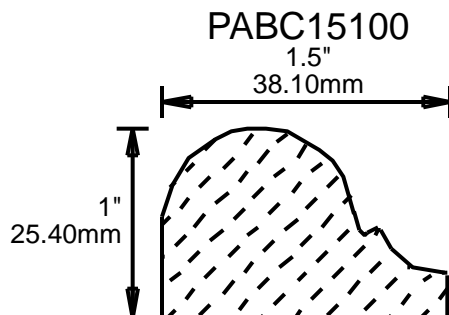
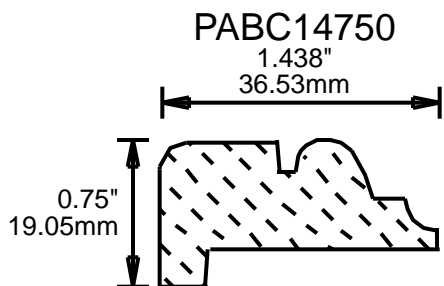
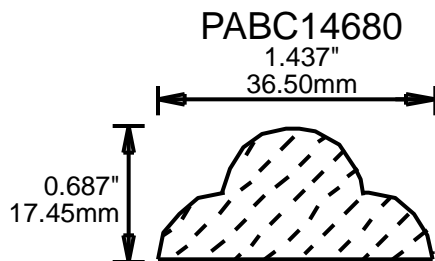
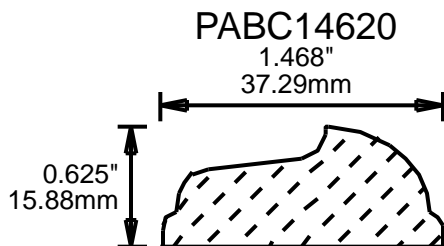
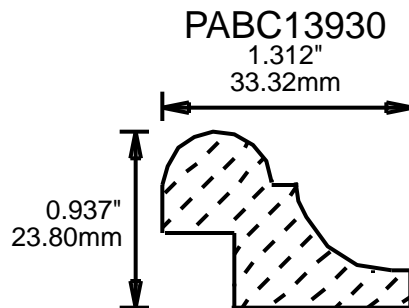
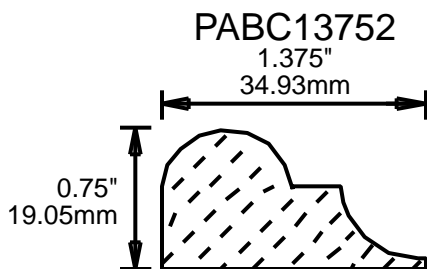
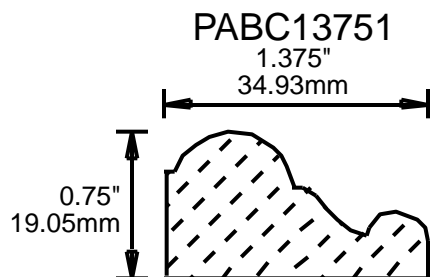
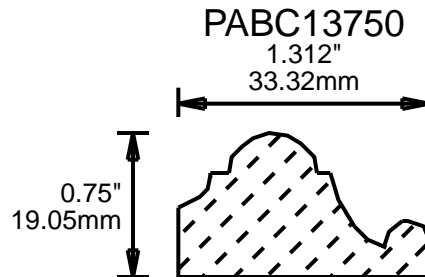
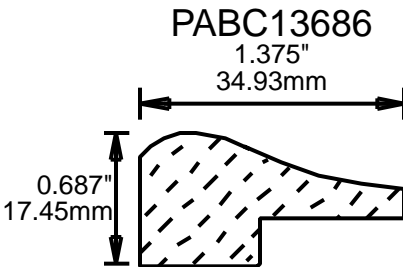
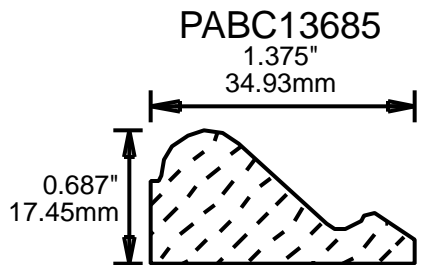
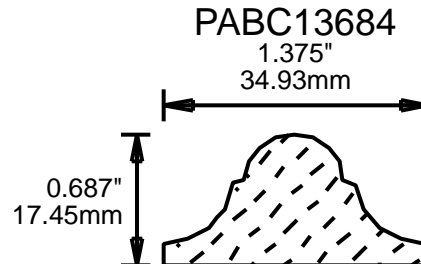
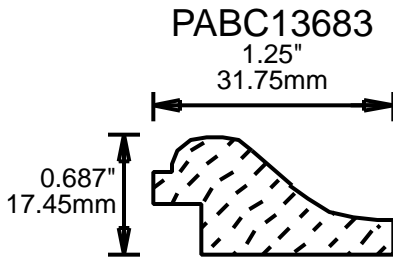
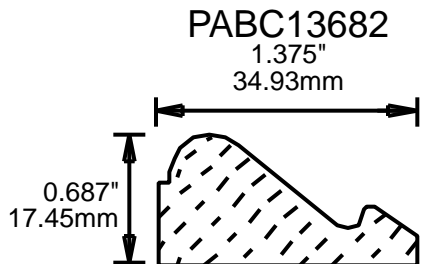

# WEINIG PANEL MOULDING PATTERNS

## BASE CAPS

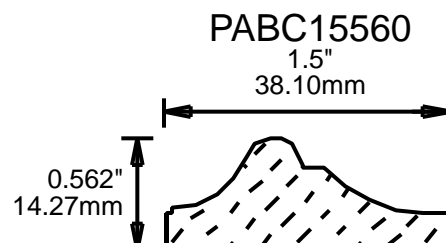
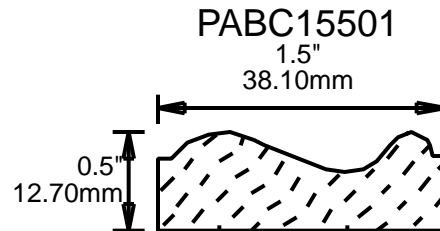
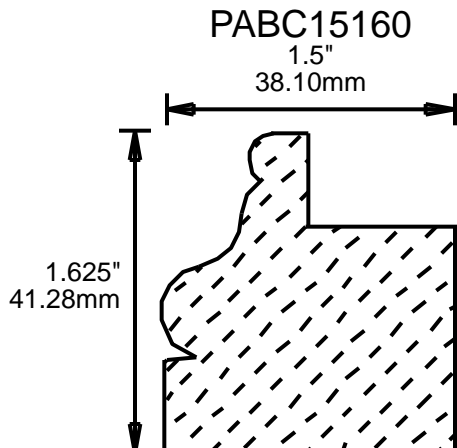
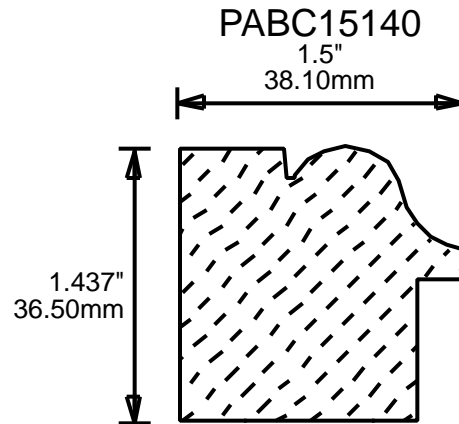
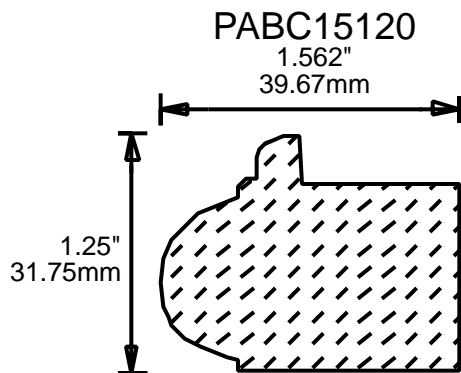
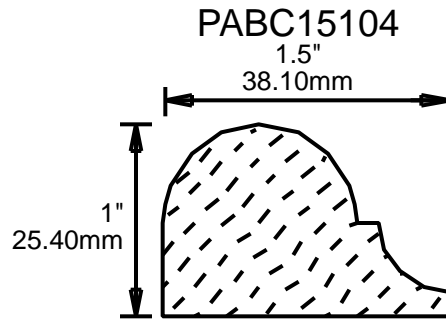
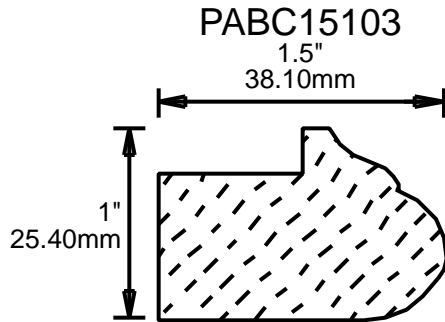
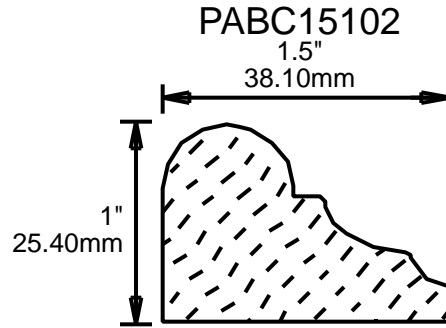
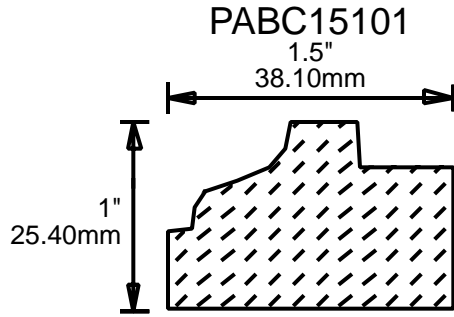

# WEINIG PANEL MOULDING PATTERNS

## BASE CAPS

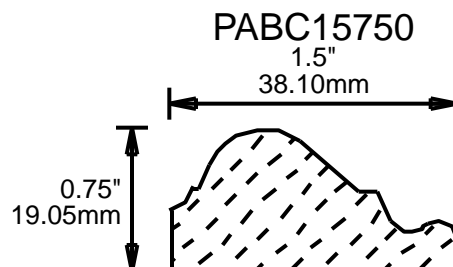
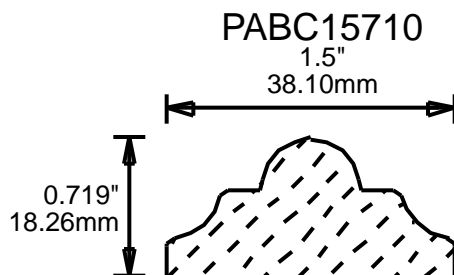
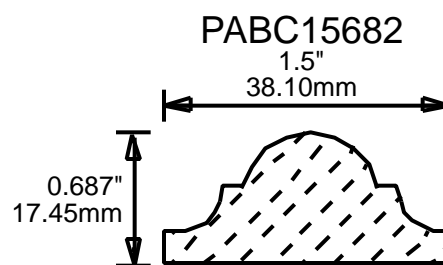
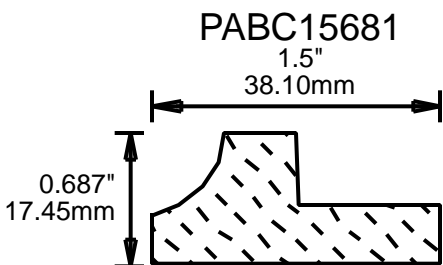
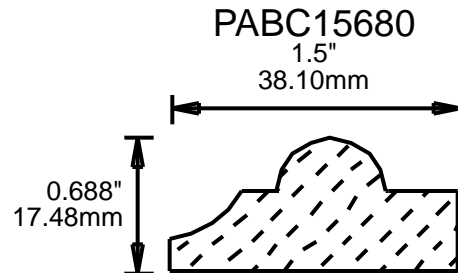
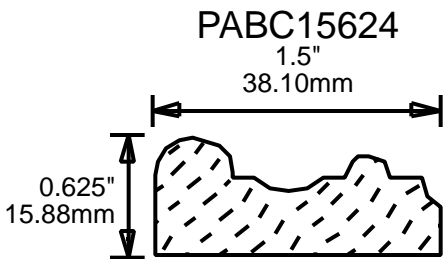
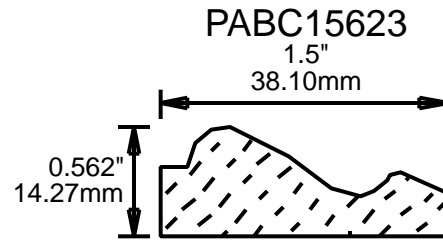
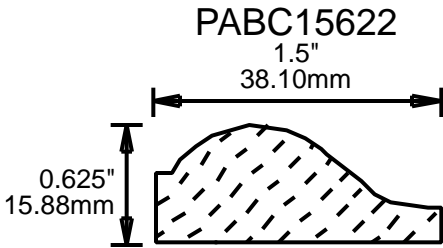
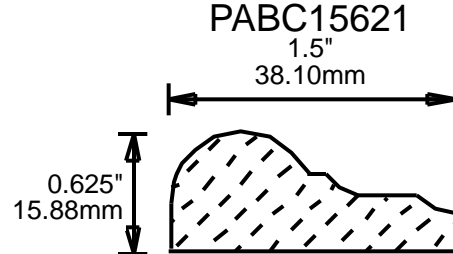
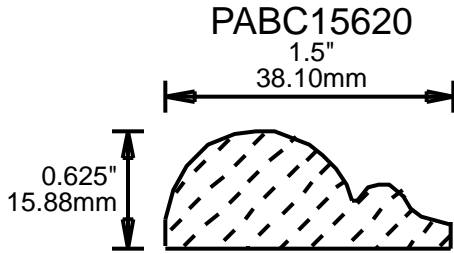

# WEINIG PANEL MOULDING PATTERNS

## BASE CAPS

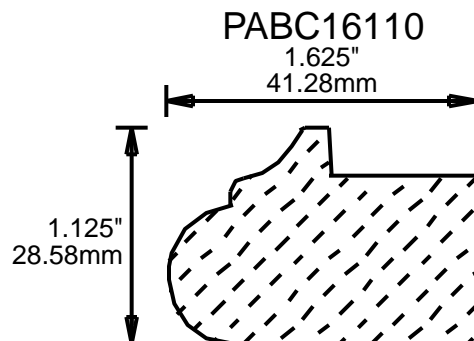
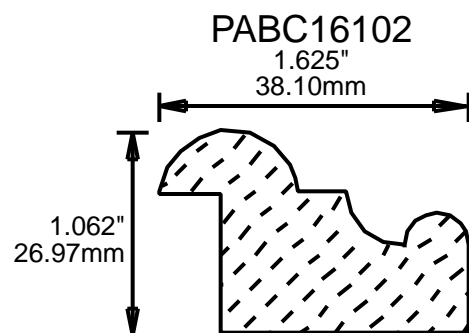
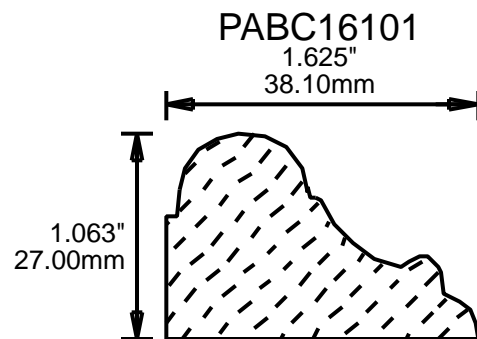
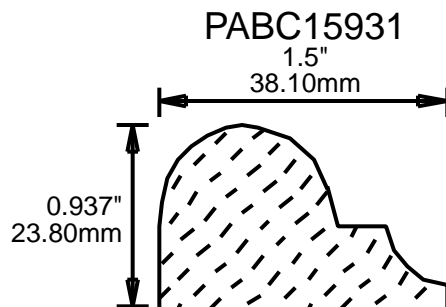
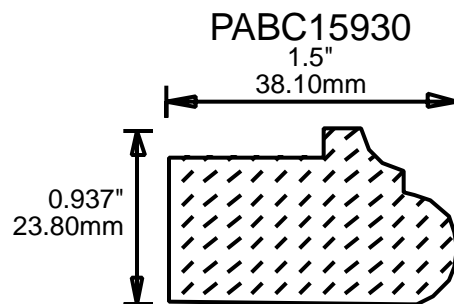
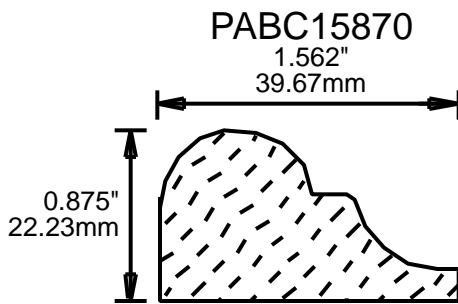
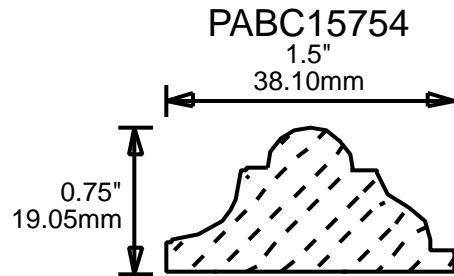
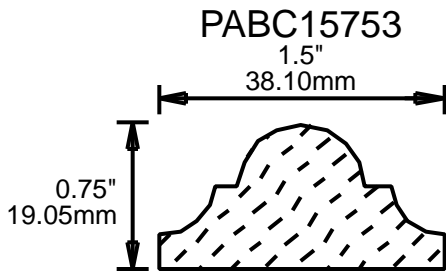
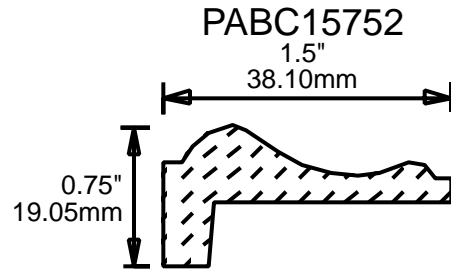
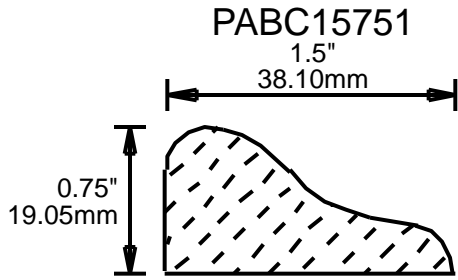

# WEINIG PANEL MOULDING PATTERNS

## BASE CAPS

**PABC16111**

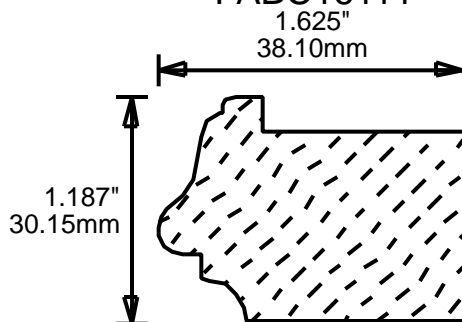

**PABC16150**

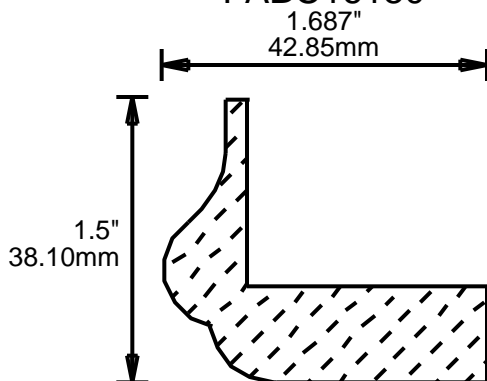

**PABC16151**

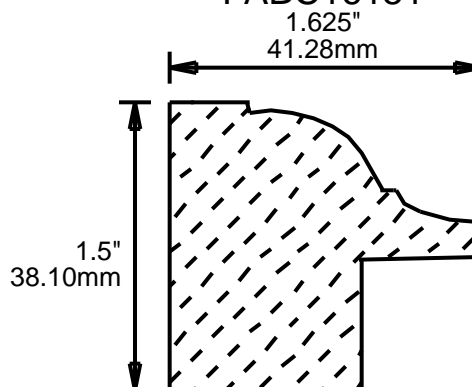

**PABC16750**

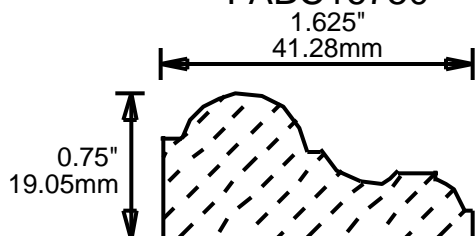

**PABC16680**

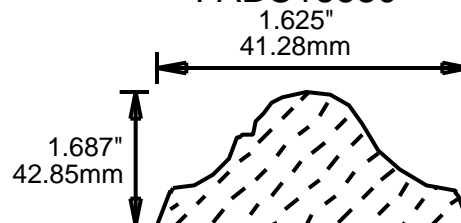

**PABC17100**

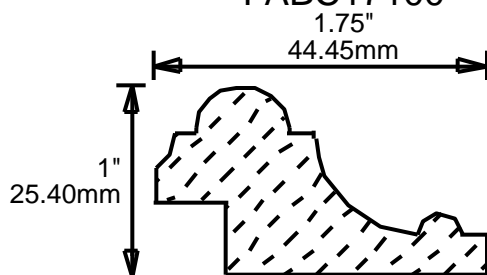

**PABC17150**

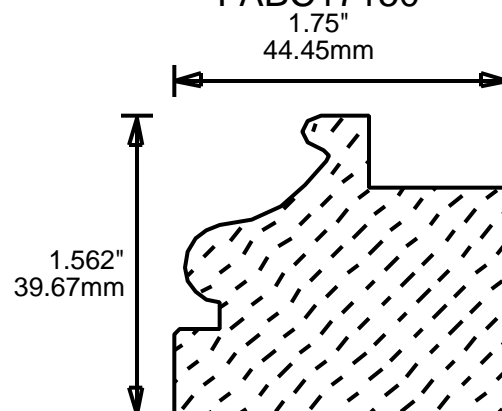

**PABC17430**

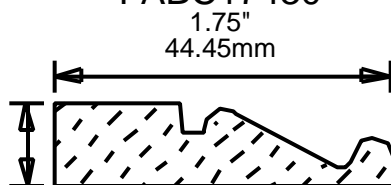

**PABC17620**

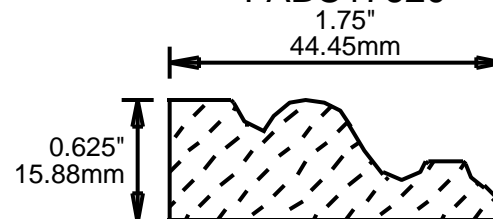

**PRINT  
THIS SECTION**

**RETURN TO  
Table of Contents**



# WEINIG PANEL MOULDING PATTERNS

## BASE CAPS

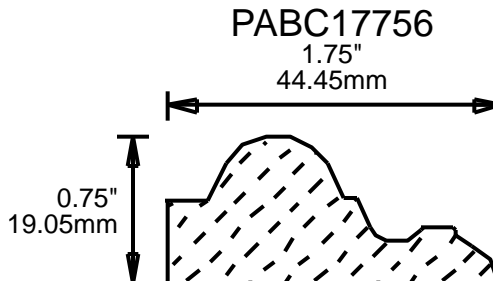
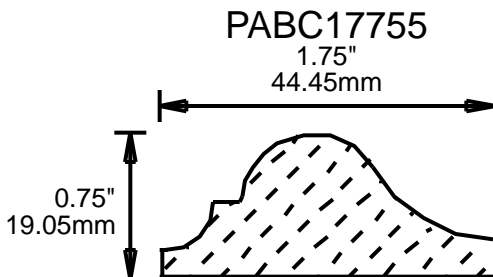
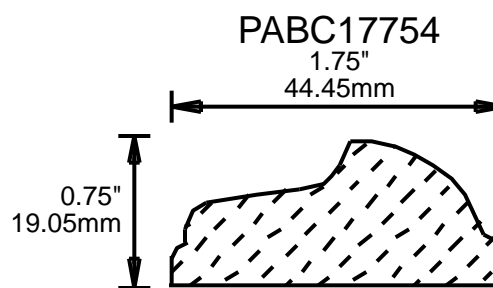
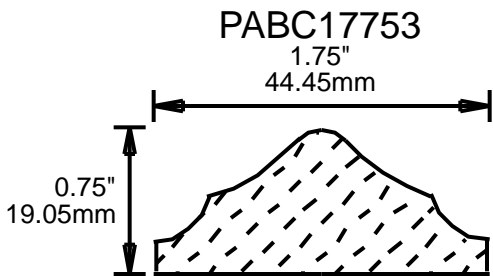
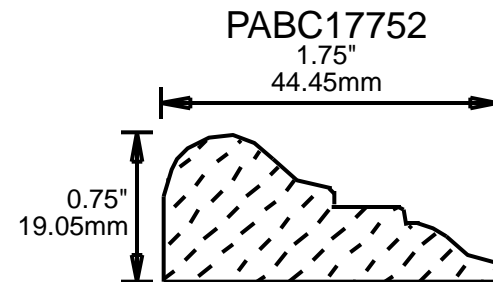
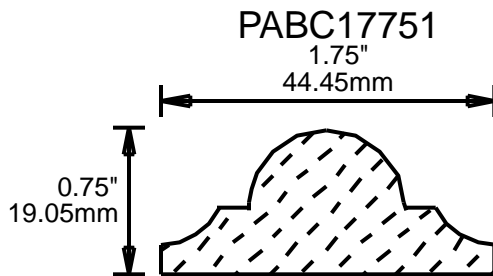
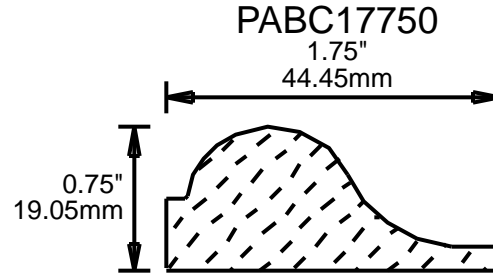
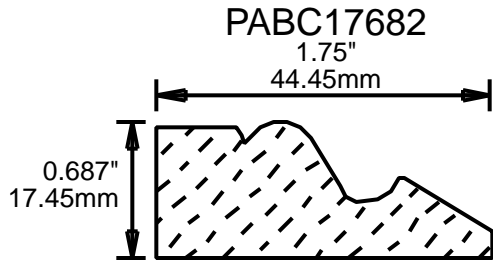
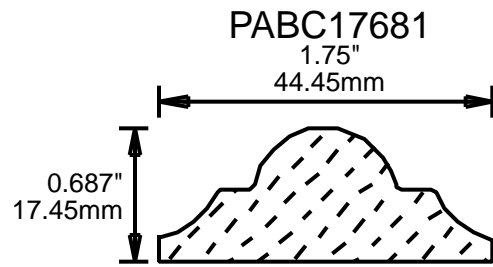
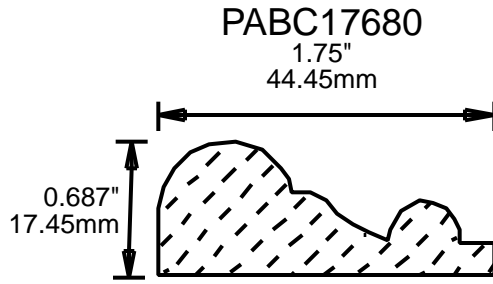

# WEINIG PANEL MOULDING PATTERNS BASE CAPS

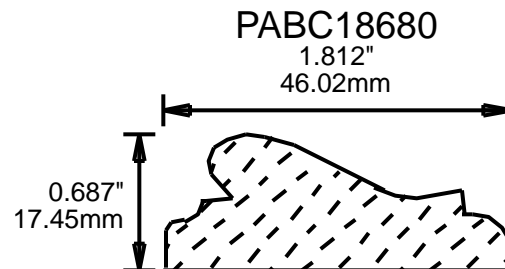
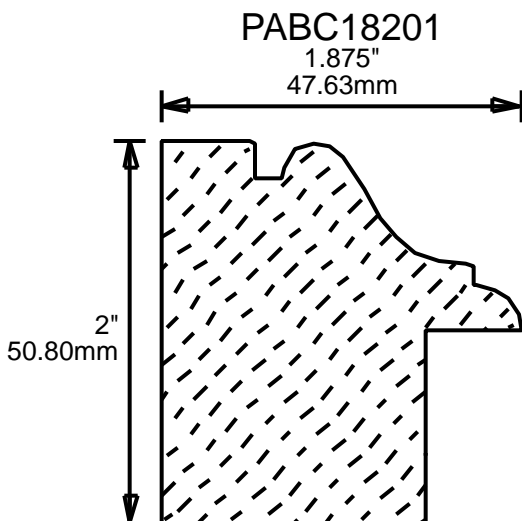
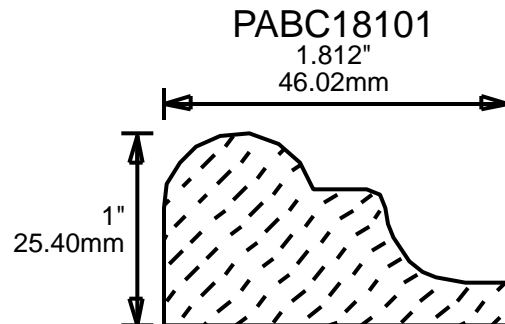
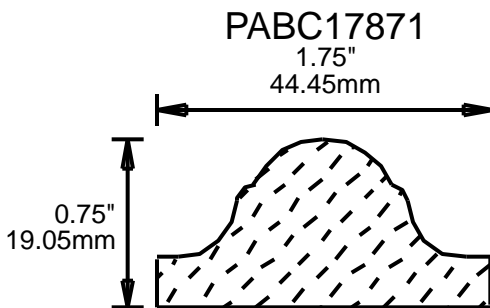
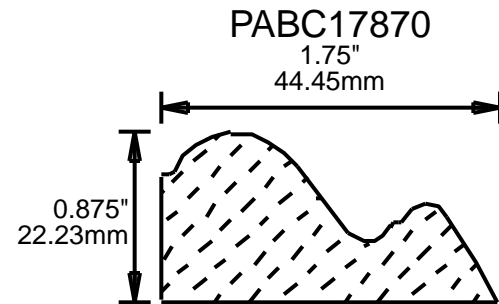
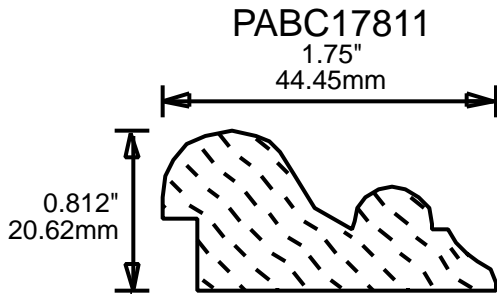
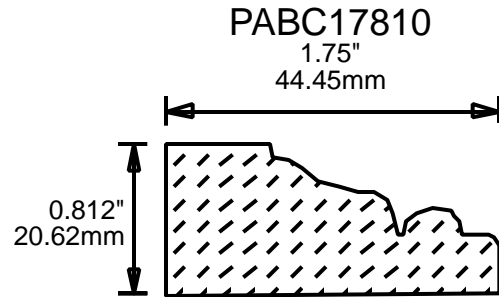
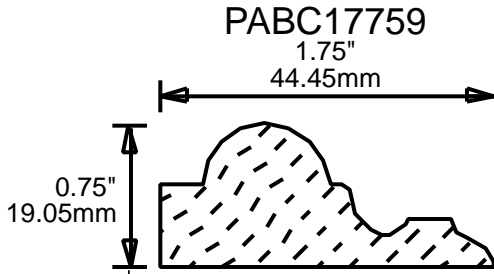
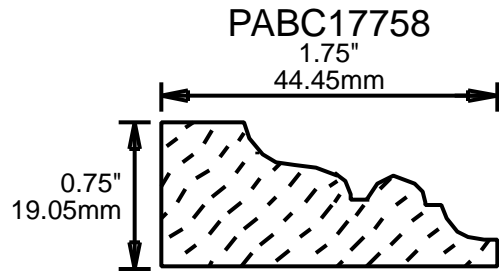
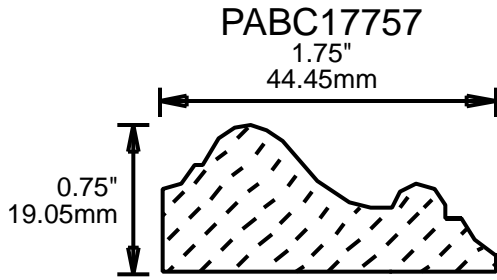

**PRINT  
THIS SECTION**

**RETURN TO  
Table of Contents**

# WEINIG PANEL MOULDING PATTERNS

## BASE CAPS

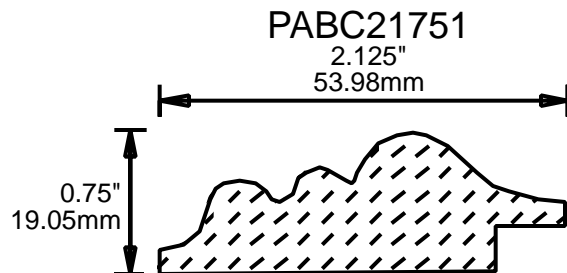
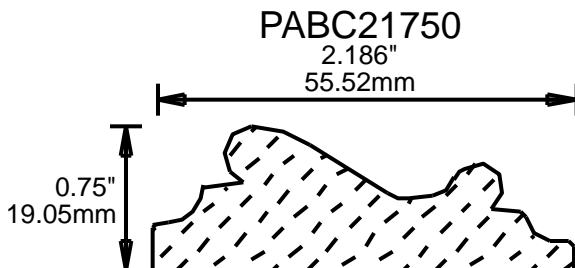
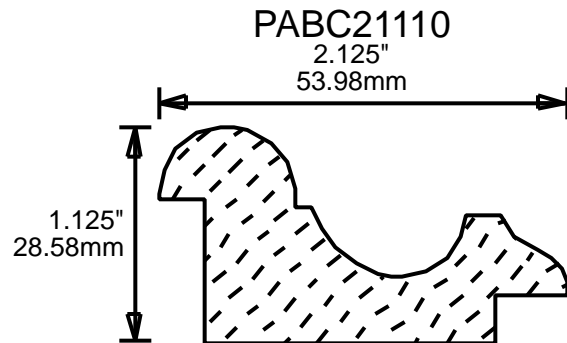
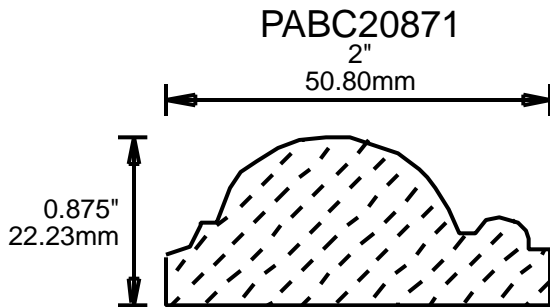
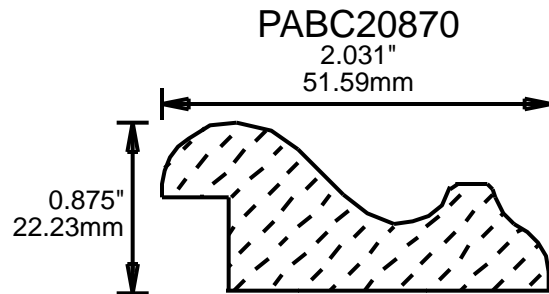
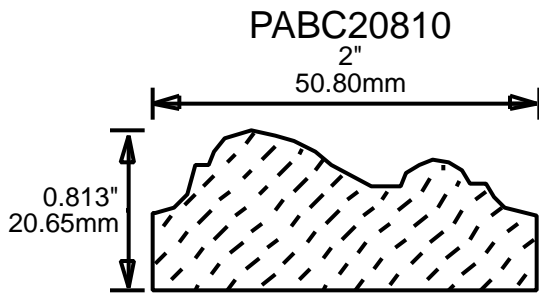
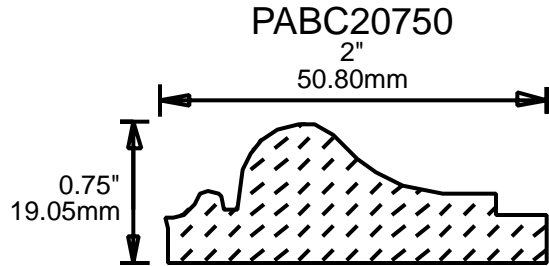
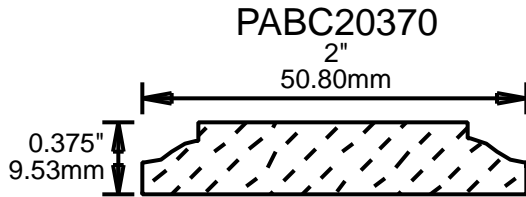
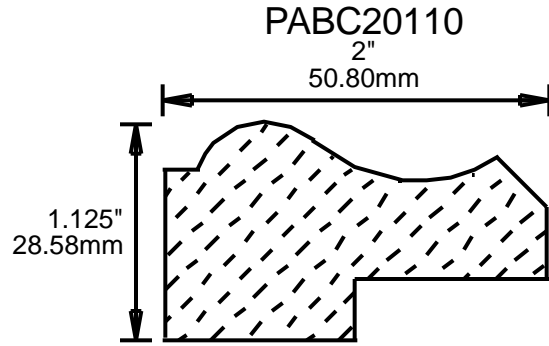
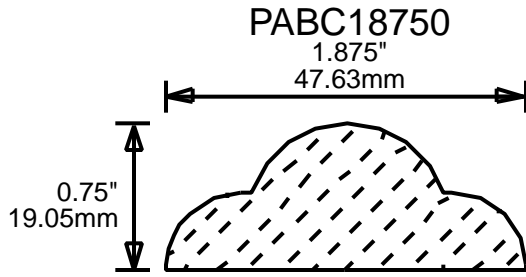

# WEINIG PANEL MOULDING PATTERNS BASE CAPS

**PABC22100**  
2.25"  
57.15mm

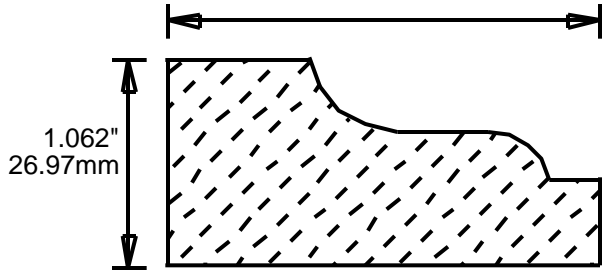

**PABC22370**  
2.25"  
57.15mm

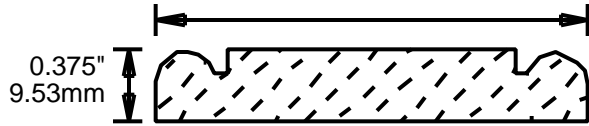

**PABC22750**  
2.25"  
57.15mm

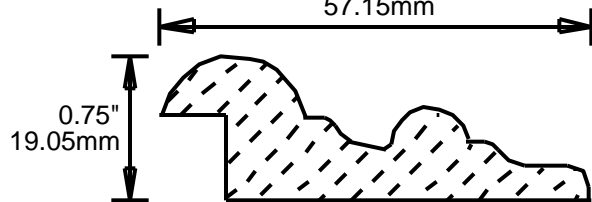

**PABC23620**  
2.313"  
58.75mm

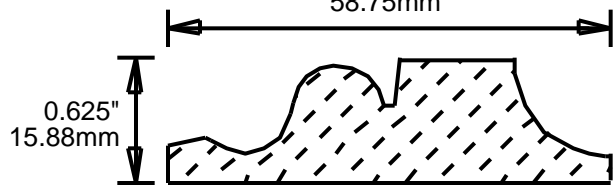

**PABC23810**  
2.375"  
60.33mm

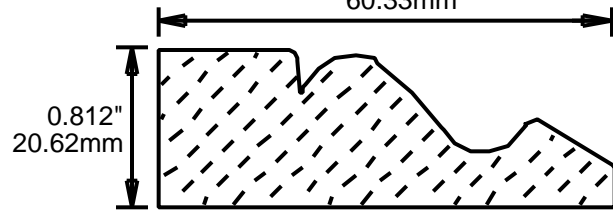

**PABC25150**  
2.5"  
63.50mm

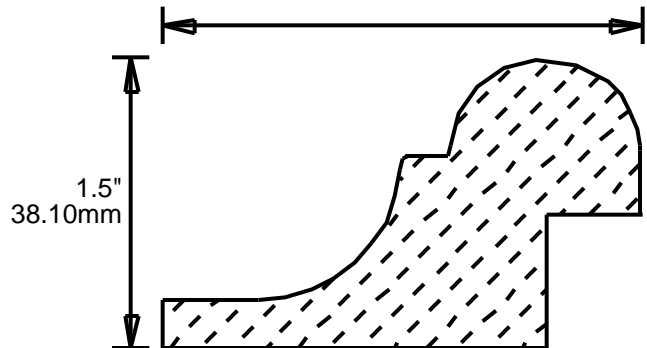

**PABC25160**  
2.5"  
63.50mm

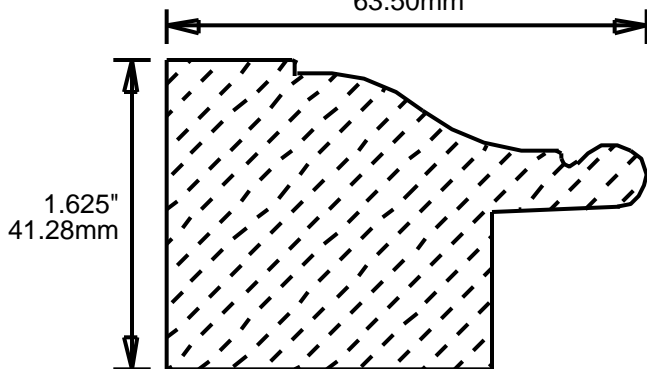

**PABC25680**  
2.5"  
63.50mm

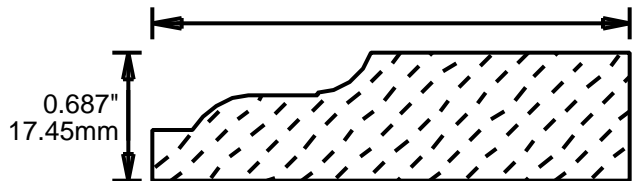

# WEINIG PANEL MOULDING PATTERNS

## BASE CAPS

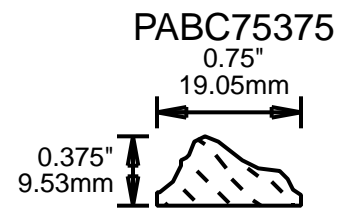
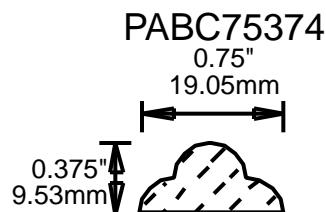
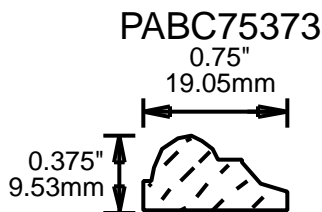
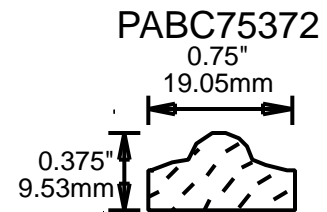
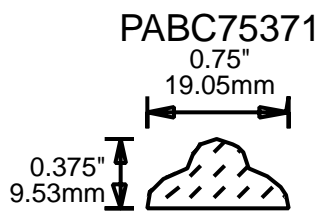
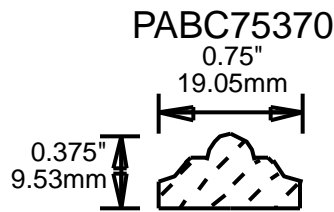
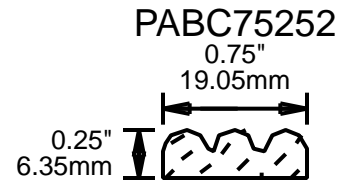
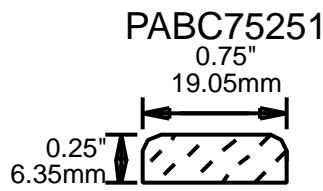
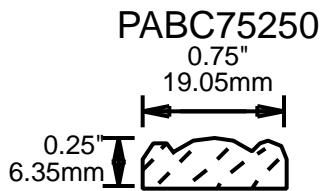
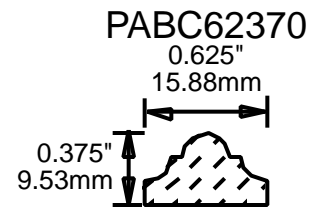
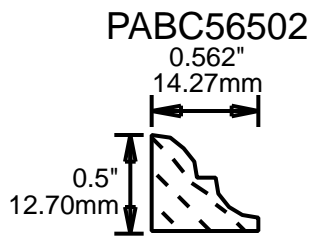
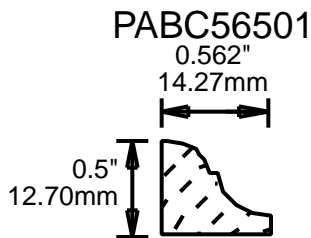
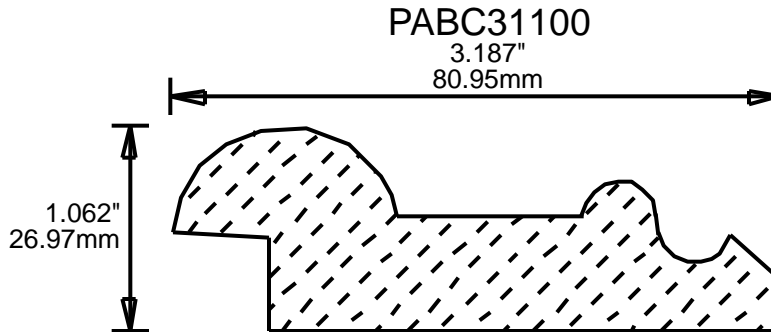
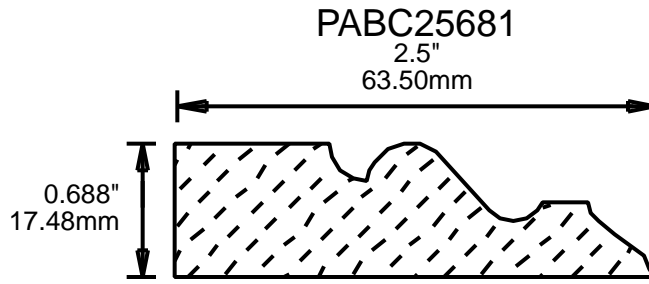

# WEINIG PANEL MOULDING PATTERNS

## BASE CAPS

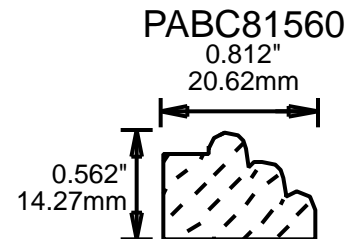
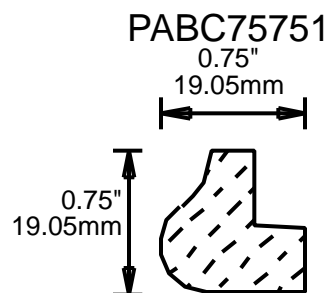
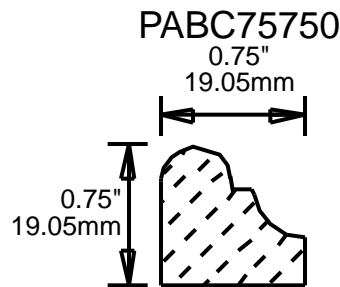
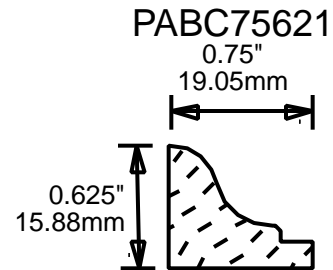
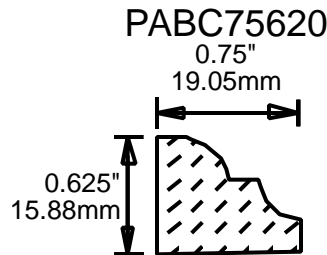
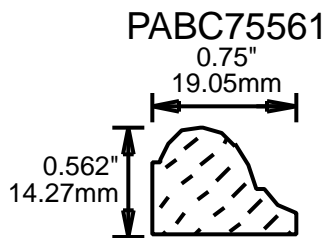
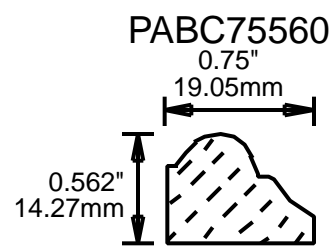
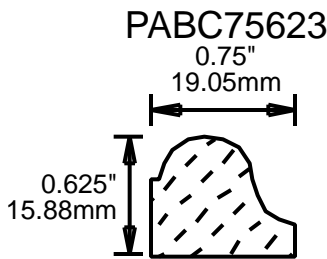
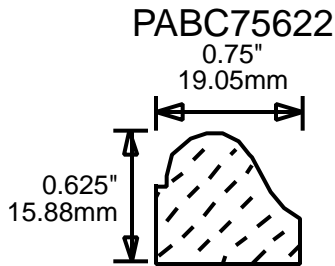
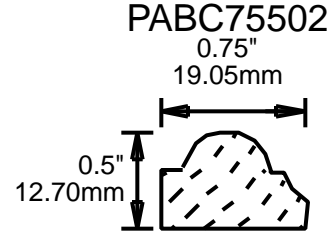
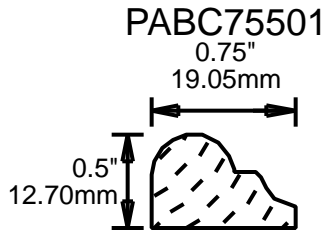
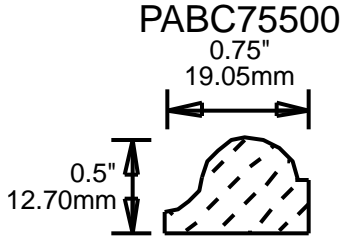
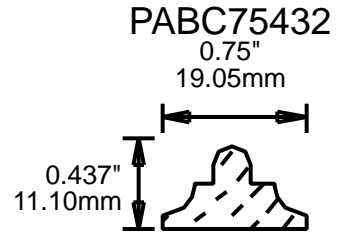
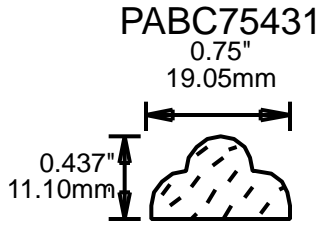
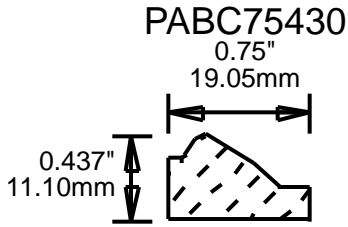

# WEINIG PANEL MOULDING PATTERNS

## BASE CAPS

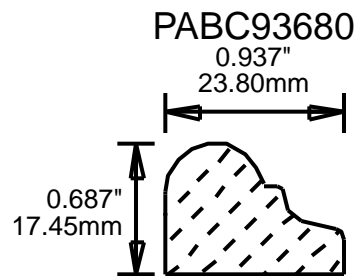
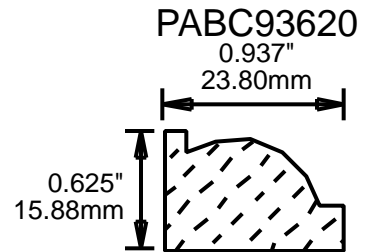
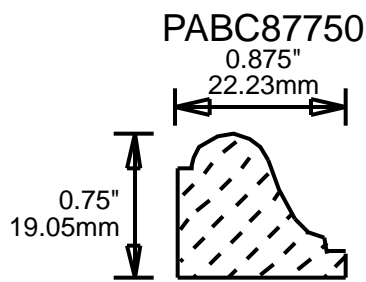
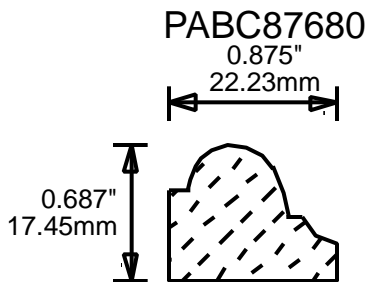
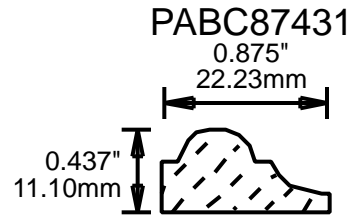
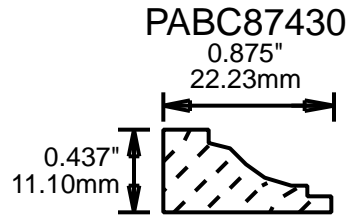
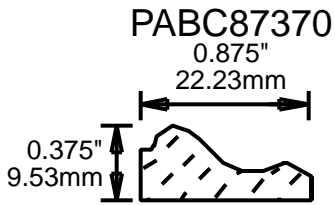
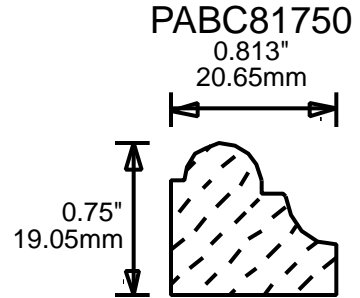
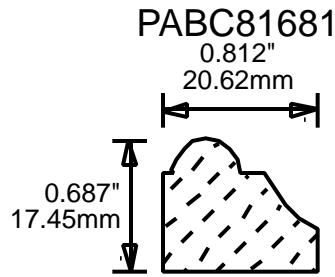
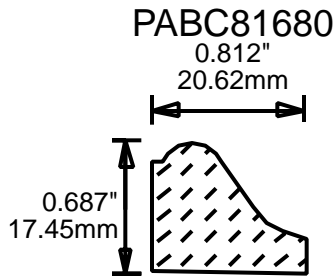

# WEINIG PANEL MOULDING PATTERNS

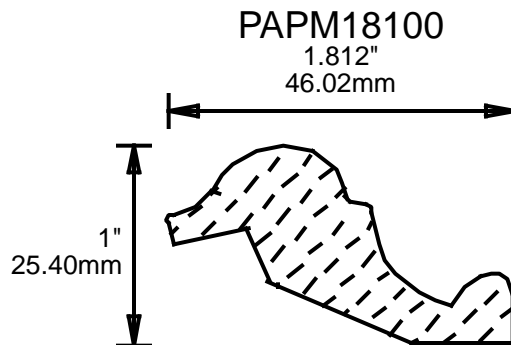
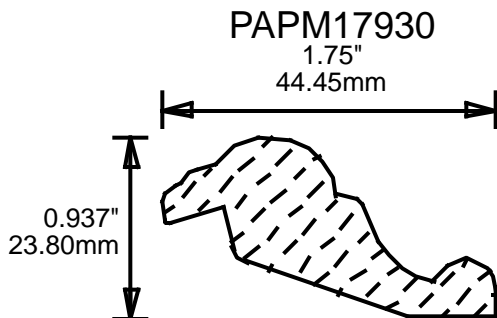
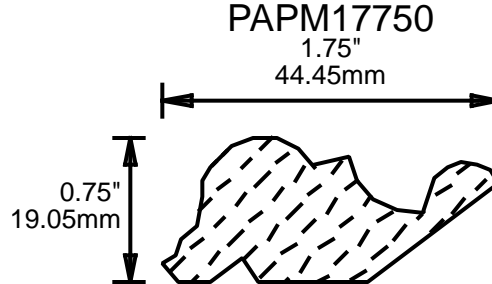
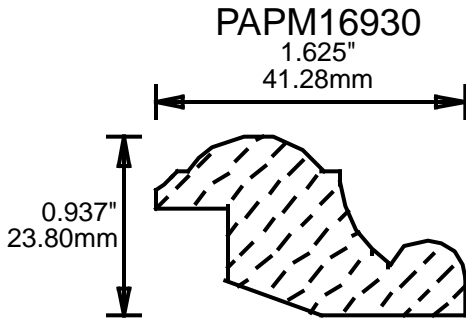
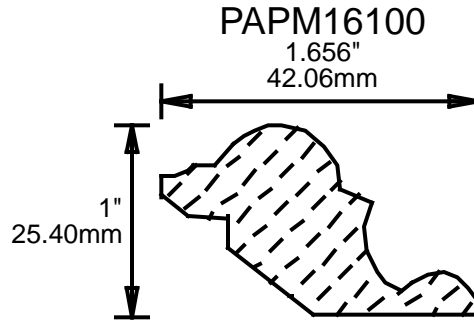
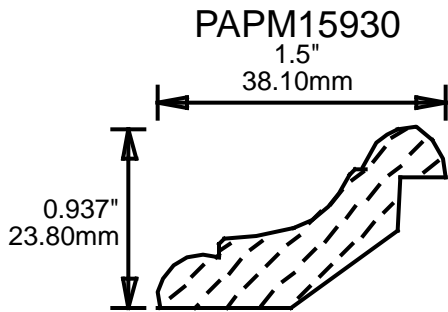
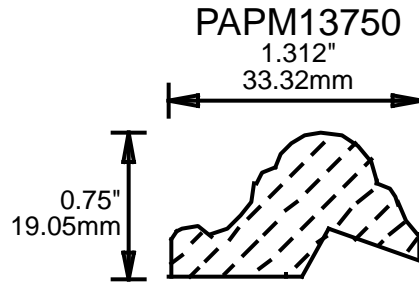
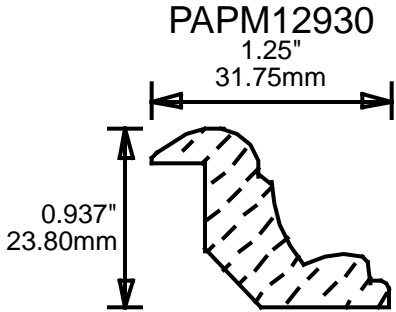



# WEINIG PANEL MOULDING PATTERNS

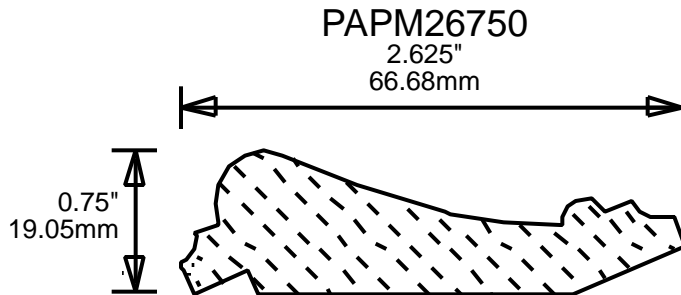
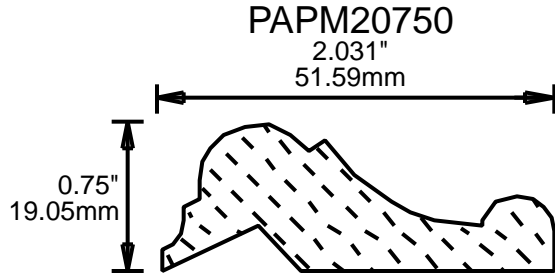
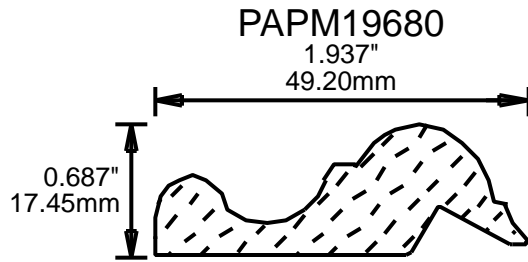
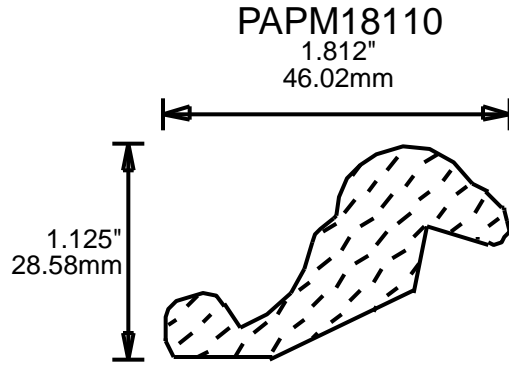
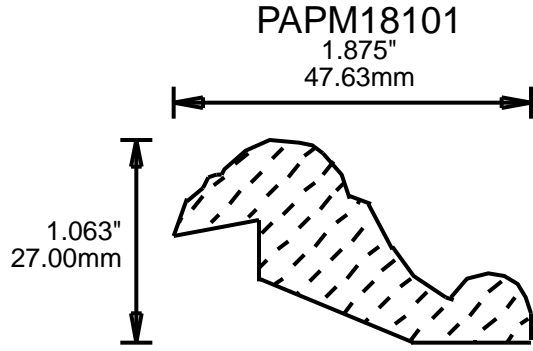

# WEINIG PANEL MOULDING PATTERNS PICTURE MOULDINGS

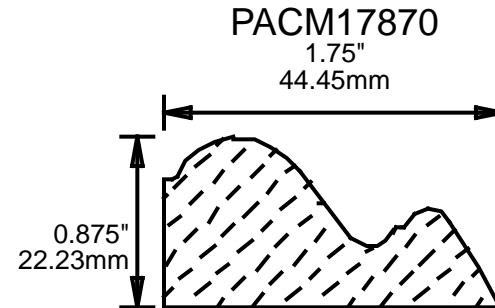
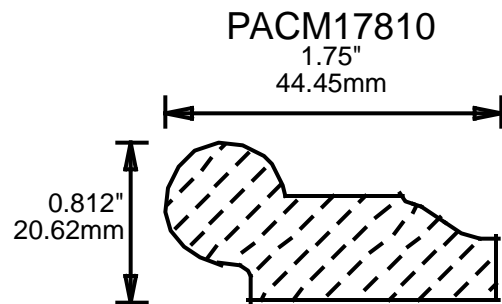
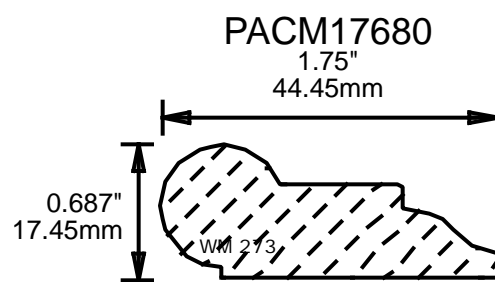
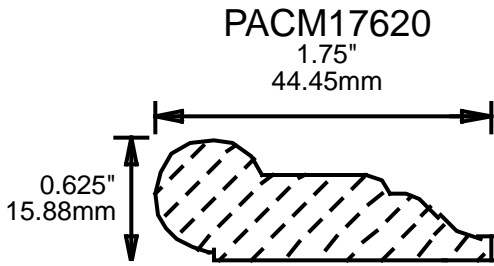
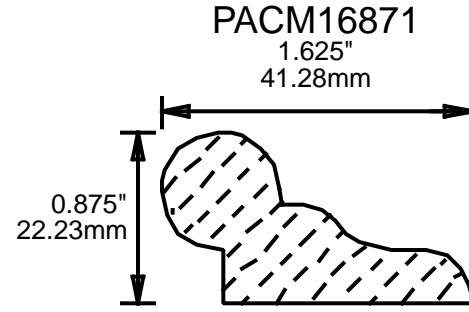
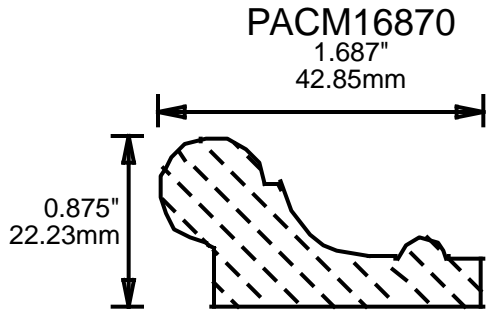
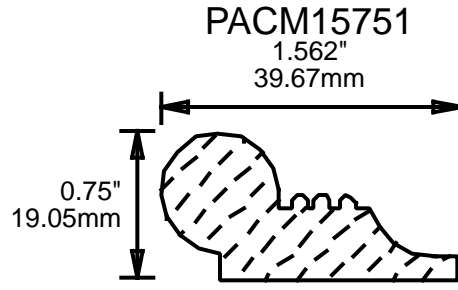
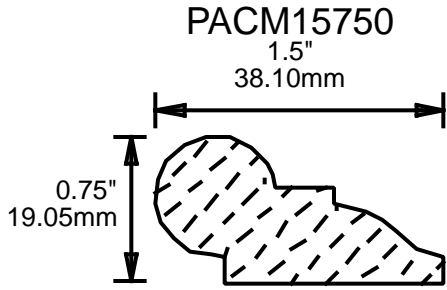

# WEINIG PANEL MOULDING PATTERNS

## PICTURE MOULDINGS

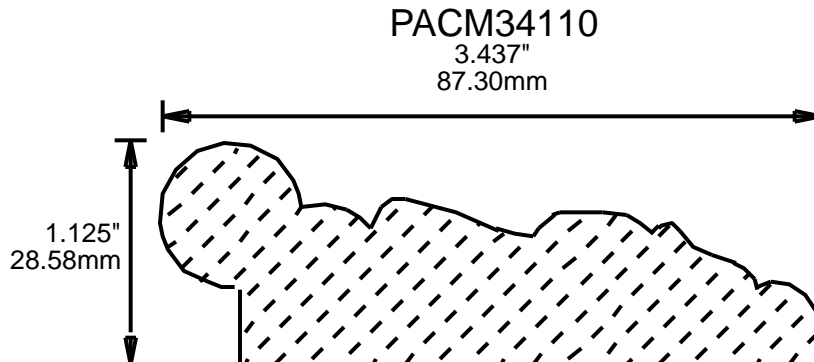
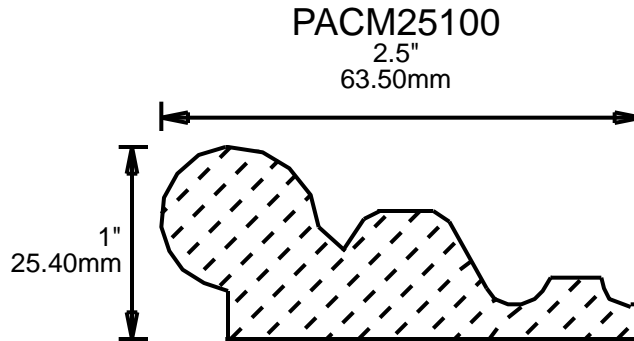
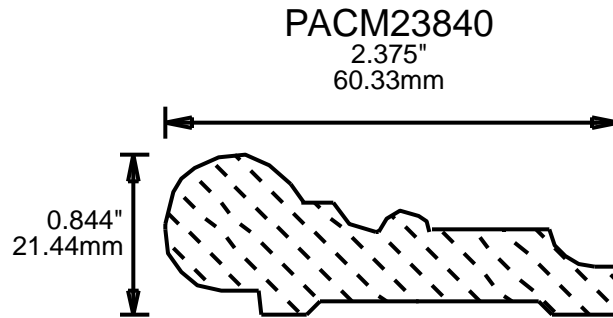
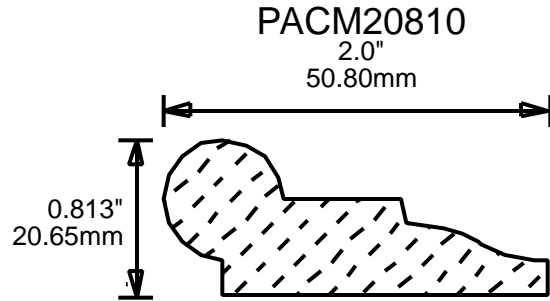
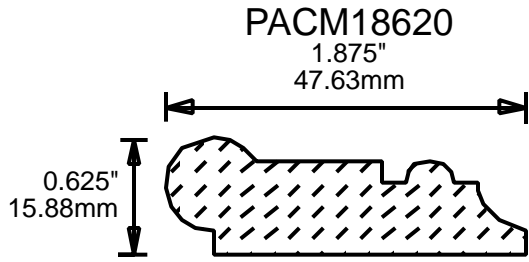

Standards and specifications for flooring and paneling products vary coast-to-coast, as well as internationally. Because of this, you should depend on your customer to tell you what standards are needed.

For maintaining the most consistent tolerances and longevity of tooling, the most efficient method is to use Weinig Tongue-and-Groove Insert Cutters.

The use of ground-to-pattern knives requires consistent checking of the product due to possible knife wear. Industry patterns sometimes show a perfectly straight cut or a 90° cut that cannot be realistically obtained with a ground-to-pattern knife. Adding a 5° or 3° taper to the tongue-and-groove then may alter the profile slightly.

The Weinig Custom Grinding Service has produced hundreds of sets of tongue-and-groove cutters for a variety of needs. Communicating with your customer and being aware of machining limitations are the keys to success in producing profitable tongue-and-groove mouldings.

## TONGUE-AND-GROOVE MOULDING PATTERNS

Example: PT 56 31 B0 1

PT	Panel with tongue, identifies product as a tongue-and-groove profile
PS	Panel with shiplap, identifies product as a shiplap
56	Thickness, as first 2 decimals
31	Width, as first 2 decimals. If side heads only are needed, the width is identified as "00"
BO	Profile key
	0 Straight vertical T&G pattern
	B Beaded profile, either one or two beads
	V V-joint, either made on sides or horizontal
	N Nail set included in profile
	P Profile included in horizontal cuts
	R Radius included

More than one key can be used in a profile.

- 1 Profile number. Some profiles have variations such as a longer tongue and some profiles are the same with the templates profiling differently.

# WEINIG TONGUE-AND-GROOVE PATTERNS

PT1000001

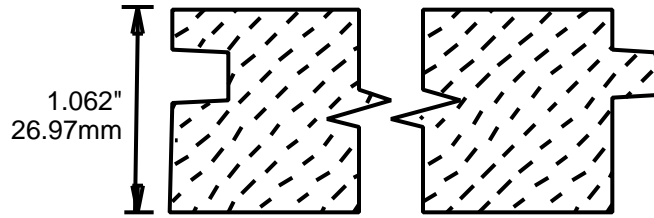

PT1000VV1

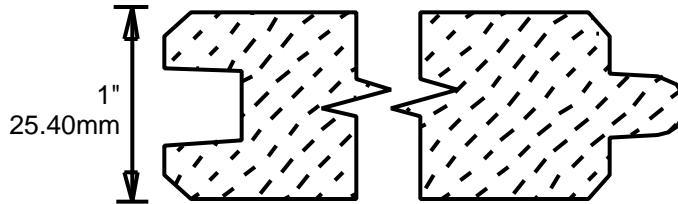

PT1155R01

5.125"

130.175mm

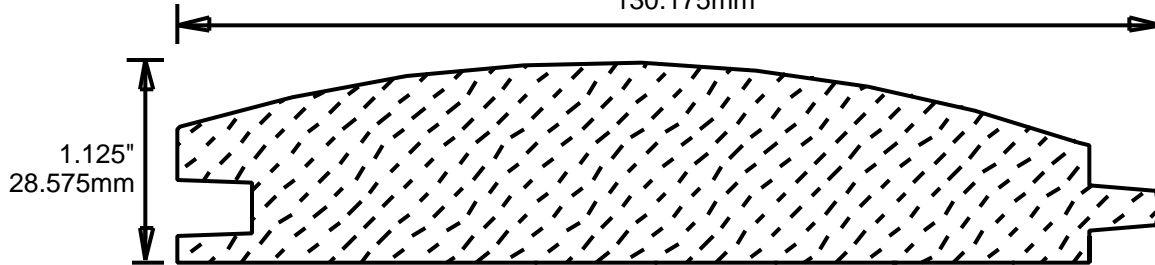

PT1170RO1

7"

177.80mm

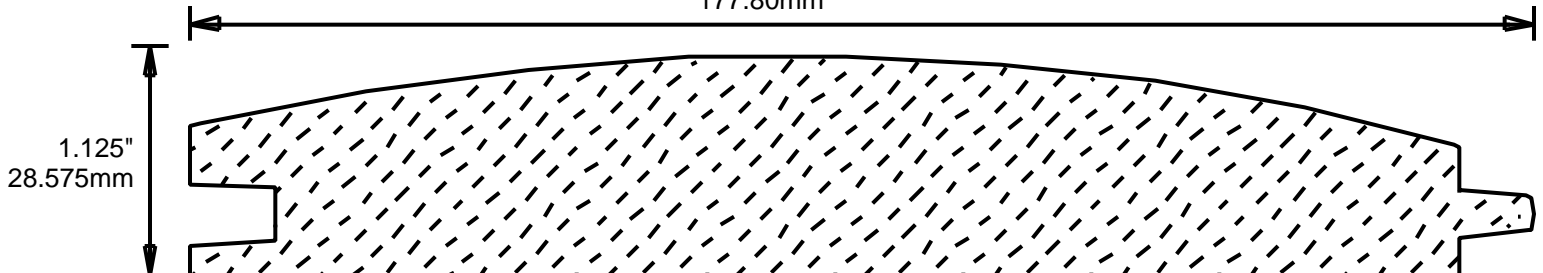

# WEINIG TONGUE-AND-GROOVE PATTERNS

PT1300VO1

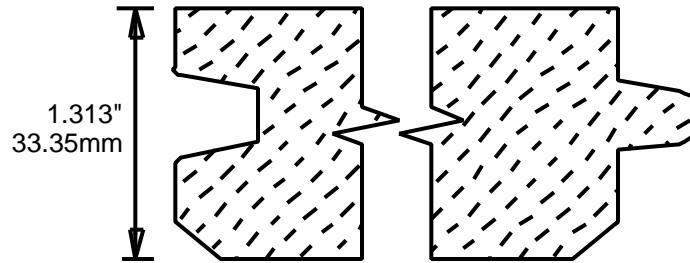

PT1347R01

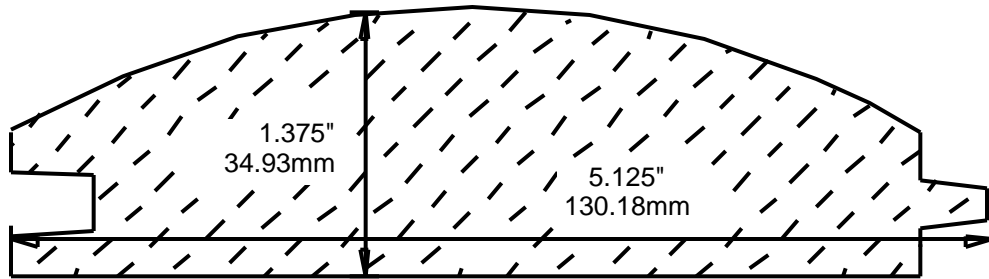

PT1365R01

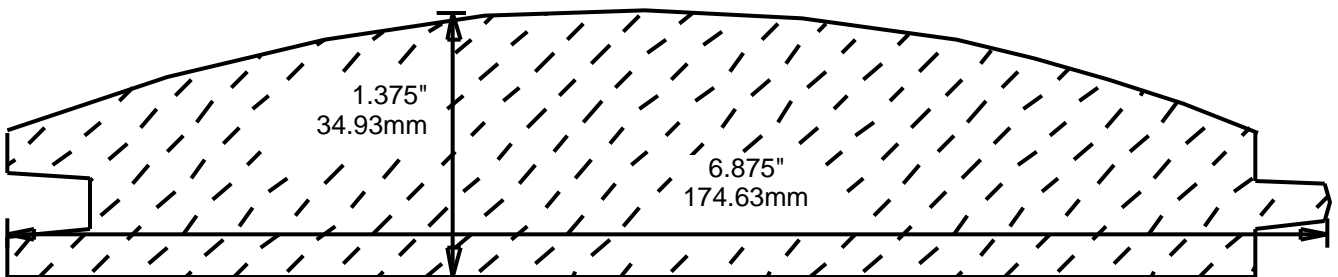

PT1400V01

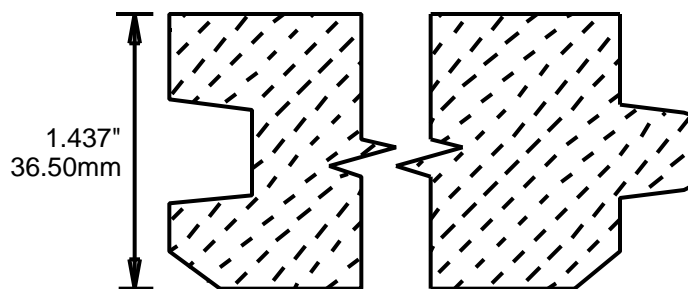

# WEINIG TONGUE-AND-GROOVE PATTERNS

PT1500001

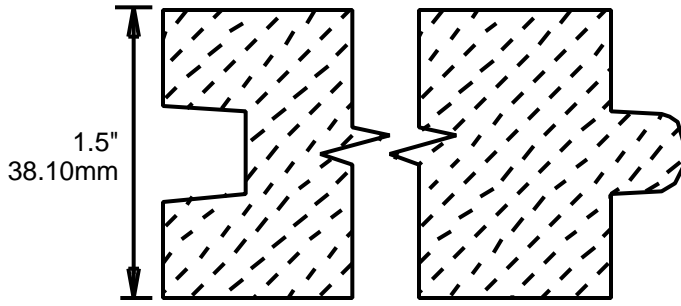

PT1500002

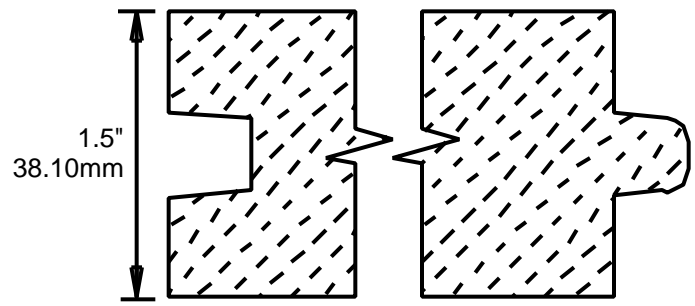

PT1500V01

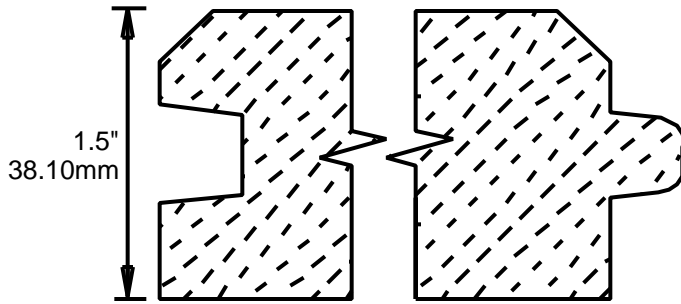

PT1500V02

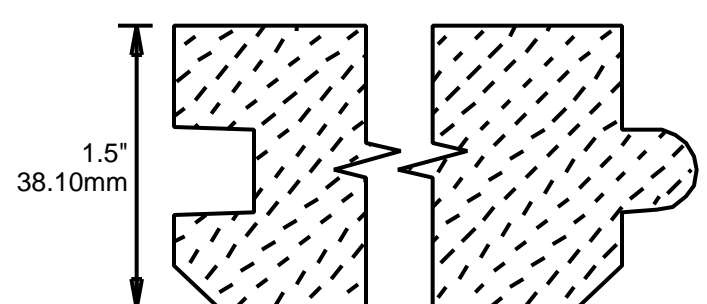

PT1500V03

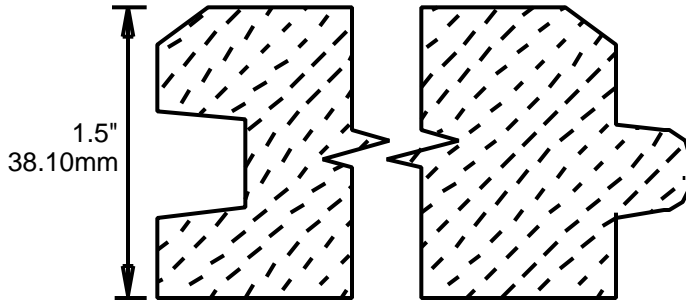

PT1500V04

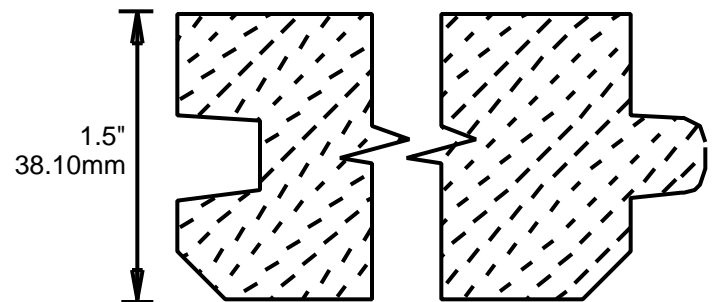

PT1500VV1

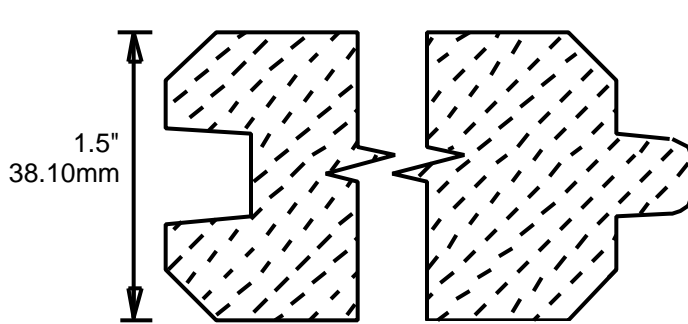

PT1600001

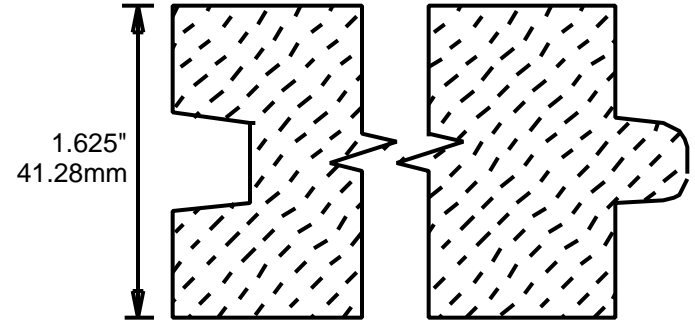

PT1700V01

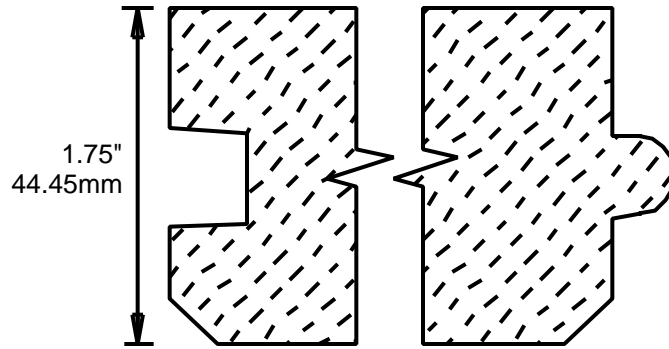

PT3145PRI

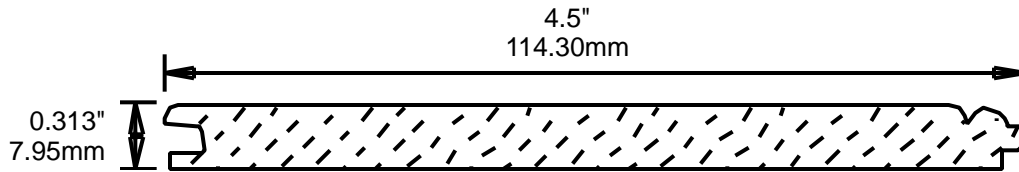

PT3500001

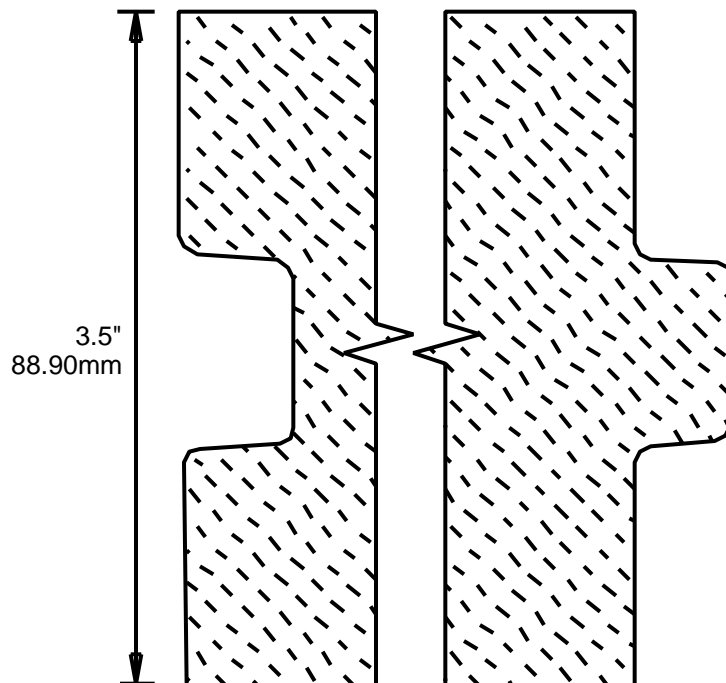



# WEINIG TONGUE-AND-GROOVE PATTERNS

PT3500VV1

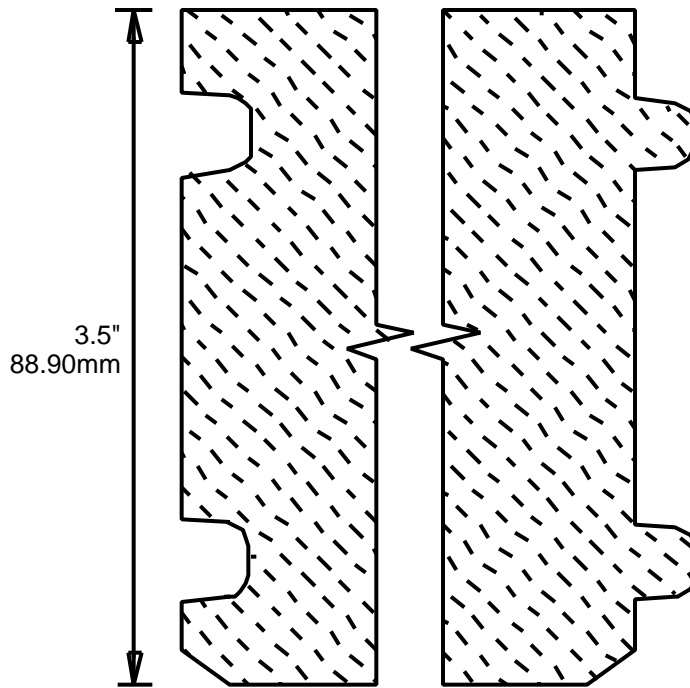

PT3700R01



PT3700V01



PT3700V02



PT3700V03

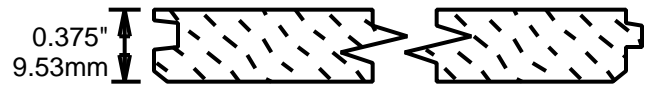

PT3725BV1

2.656"  
67.46mm

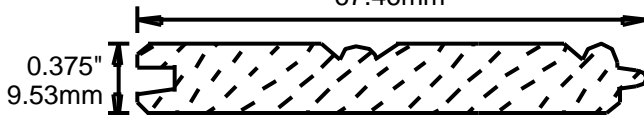

PT3730B01

3.156"  
80.16mm

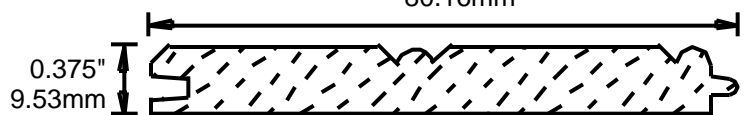

PT3730B02

3.0"  
76.20mm

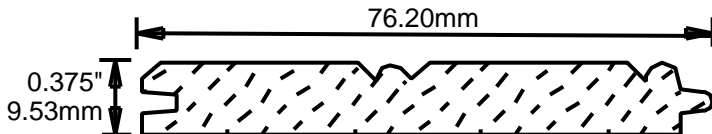

PT3731PV1

3.156"  
80.162mm

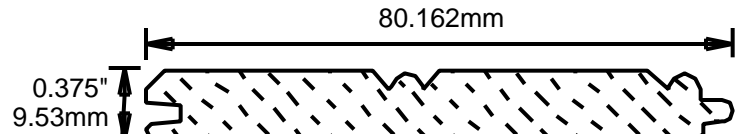

# WEINIG TONGUE-AND-GROOVE PATTERNS

PT3732B01  
3.406"  
86.51mm

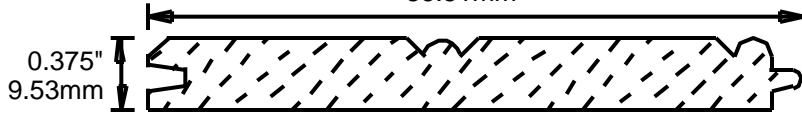

PT3733BV1  
3.344"  
84.94mm

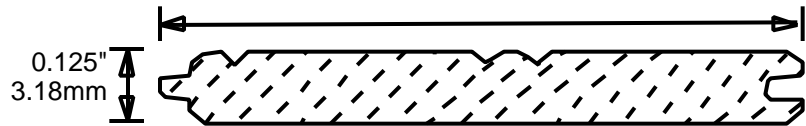

PT3736PV1  
3.656"  
92.86mm

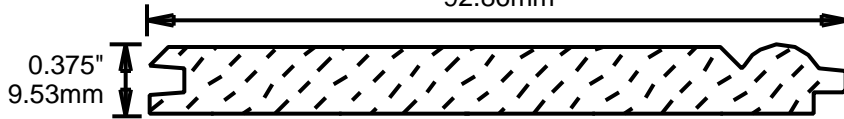

PT4300R01



PT4300V01



PT4300V02

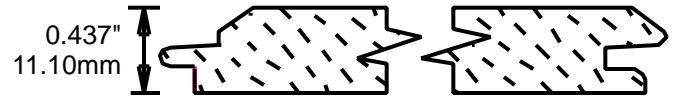

PT4331B01  
3.343"  
84.91mm

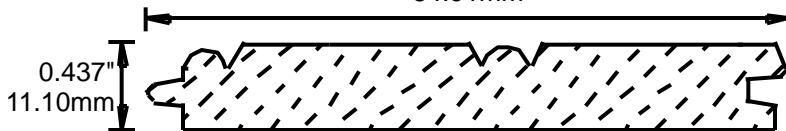

PT4331B02  
3.312"  
84.12mm

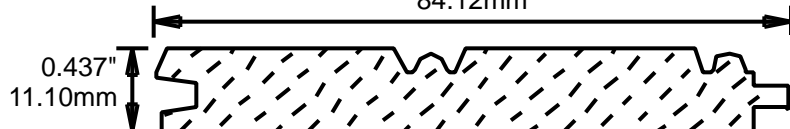

# WEINIG TONGUE-AND-GROOVE PATTERNS

PT4351VV1

5.153"  
130.89mm

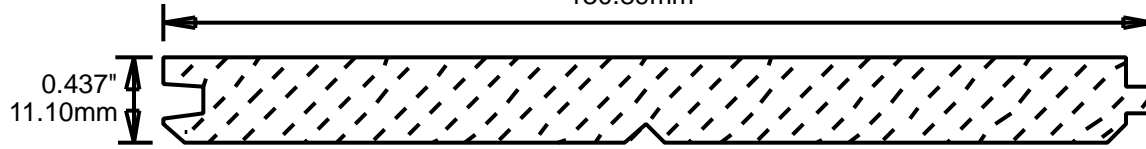

PT4354RR1

5.437"  
138.10mm

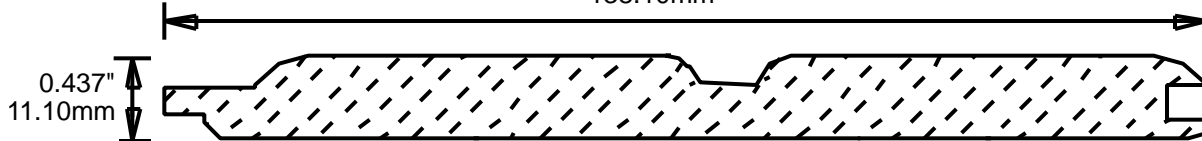

PT5000001

0.5"  
12.70mm

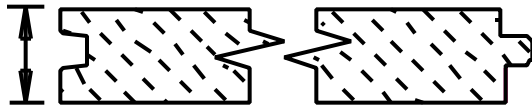

PT5000002

0.5"  
12.70mm

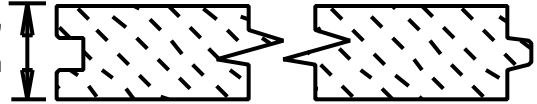

PT5000003

0.5"  
12.70mm

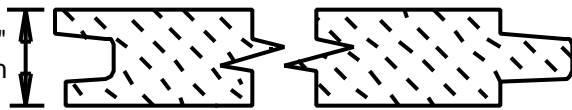

PT5000R01

0.5"  
12.70mm

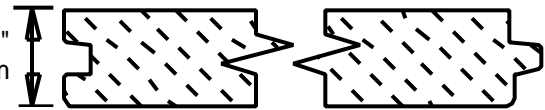

PT5000V01

0.5"  
12.70mm

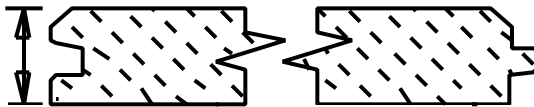

PT5631B01

3.312"  
84.12mm

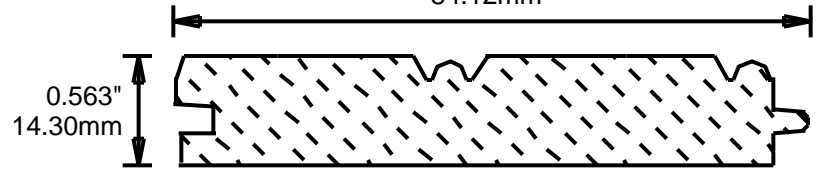

PT5631BV1

3.312"  
84.12mm

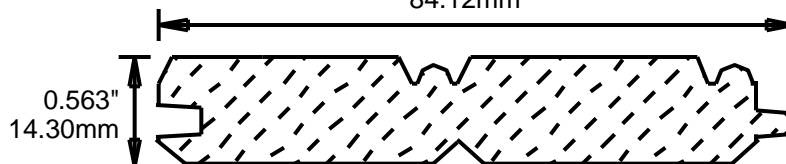

PT5631BV2

3.313"  
84.15mm

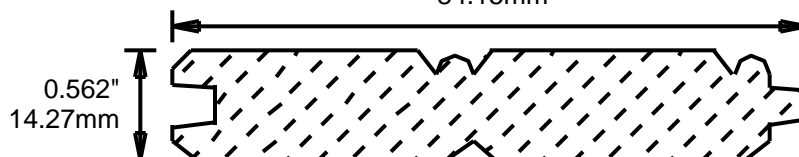

# WEINIG TONGUE-AND-GROOVE PATTERNS

PT5651BV1

5.313"

134.95mm

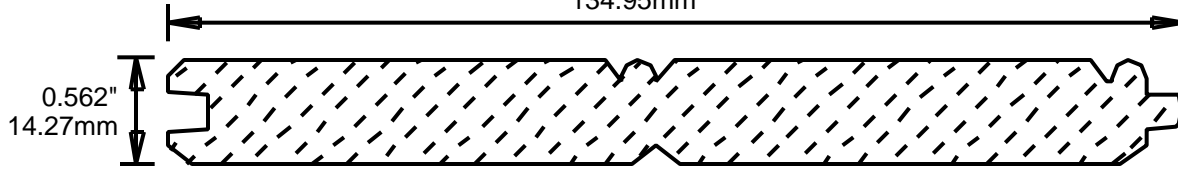

PT6200N01

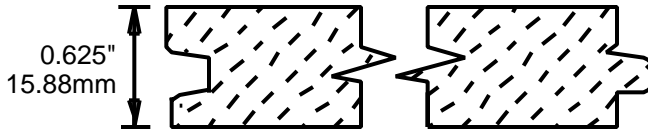

PT6200R01

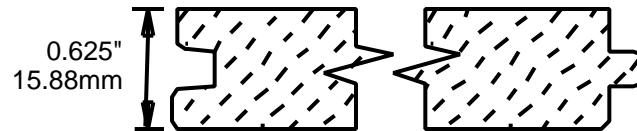

PT6200VN1

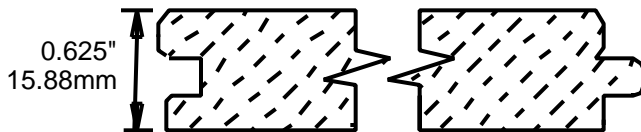

PT6200VN2

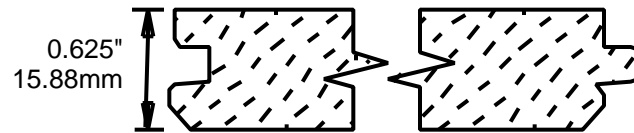

PT6200VN3

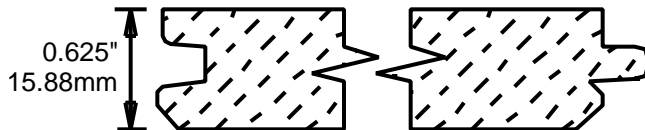

PT6200V01

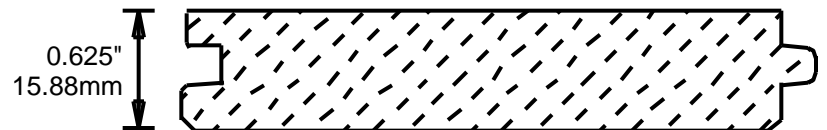

PT6251BV1

5.375"

136.53mm

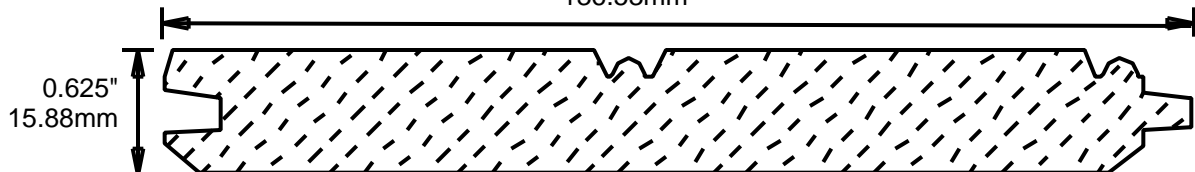

# WEINIG TONGUE-AND-GROOVE PATTERNS

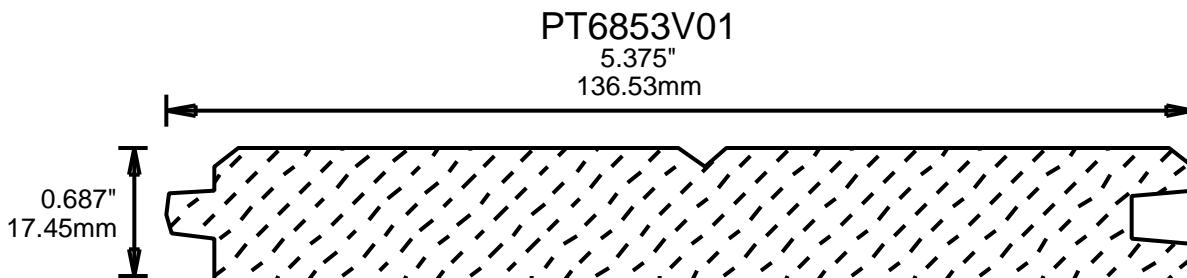
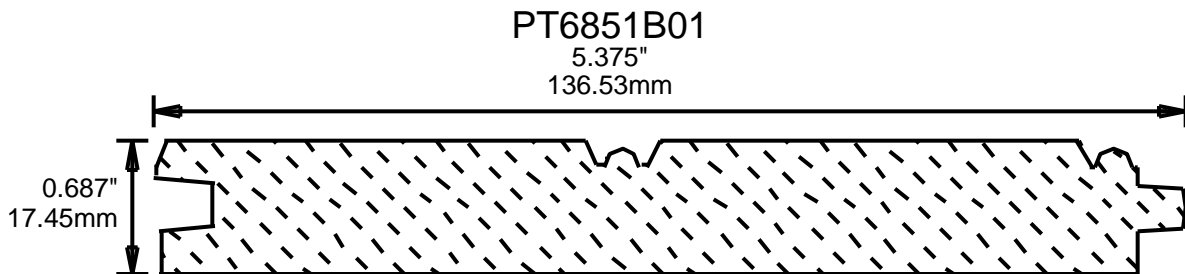
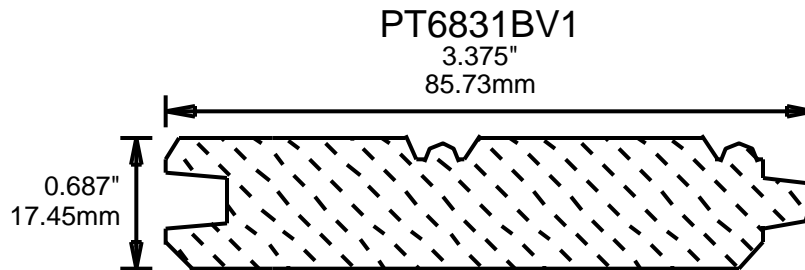
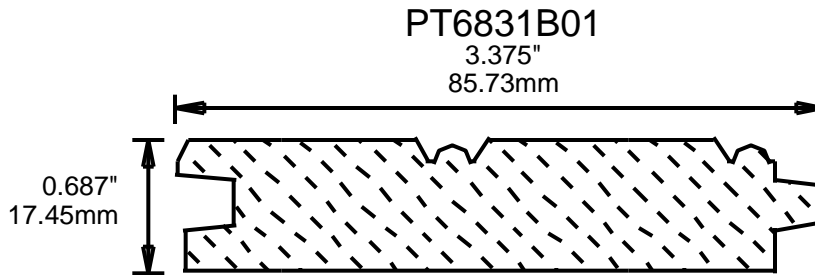
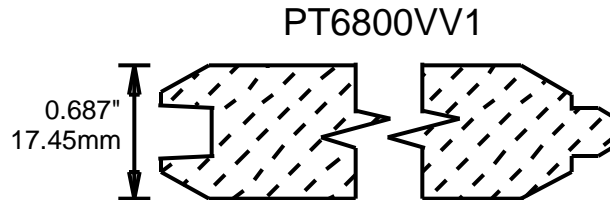
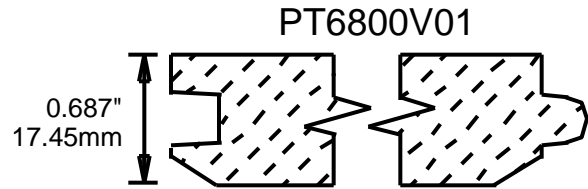
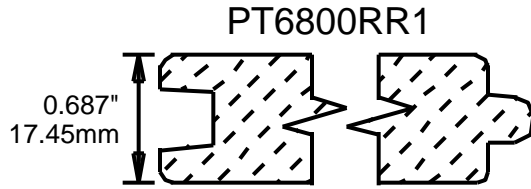

# WEINIG TONGUE-AND-GROOVE PATTERNS

PT6868B01  
7.125"  
180.98mm

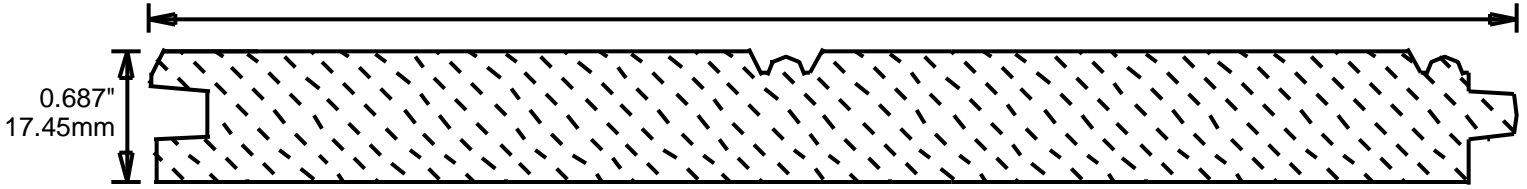

PT7100001

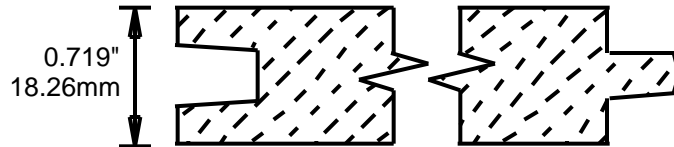

PT7100B01  
4.375"  
111.13mm

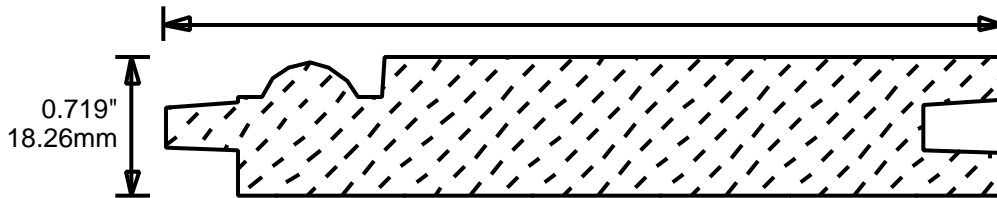

PT7100PV1

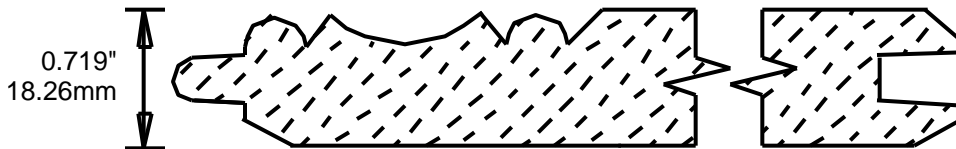

PT7100PV2

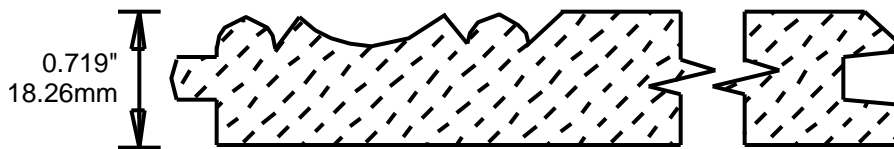

PT7100PV3

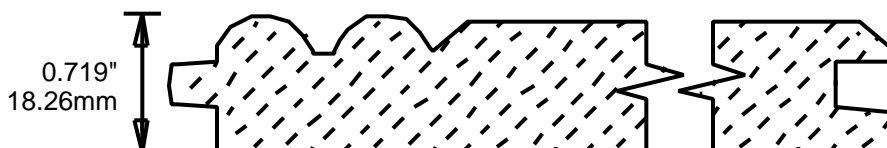

# WEINIG TONGUE-AND-GROOVE PATTERNS

PT7100PV4

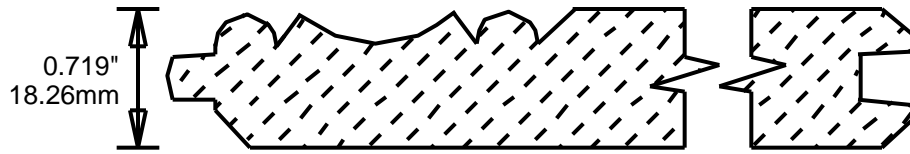

PT7100PV5

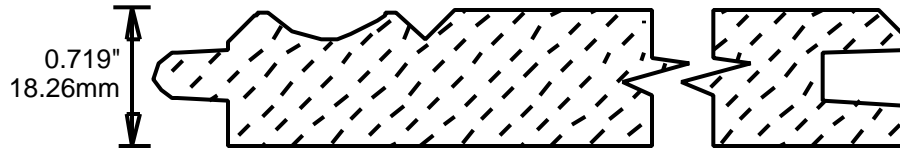

PT7100V01

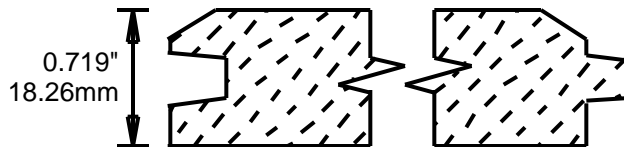

PT7100V02

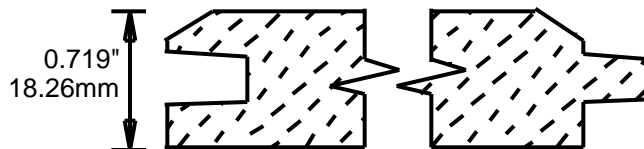

PT7100VV1

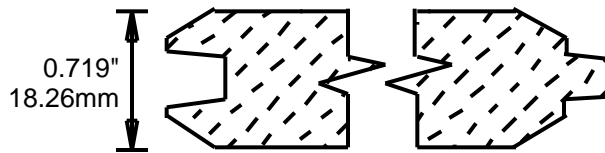

PT7100VV2

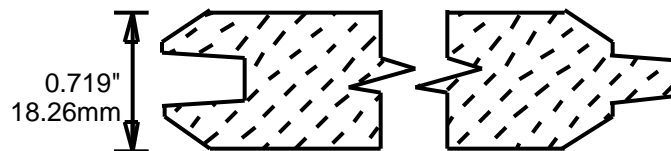

PT7100VV3

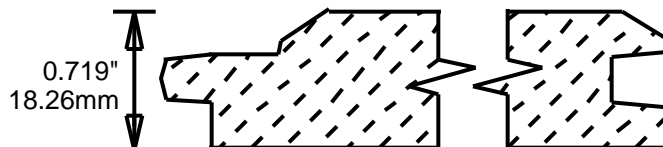

# WEINIG TONGUE-AND-GROOVE PATTERNS

PT7131B01

3.375"  
85.725mm

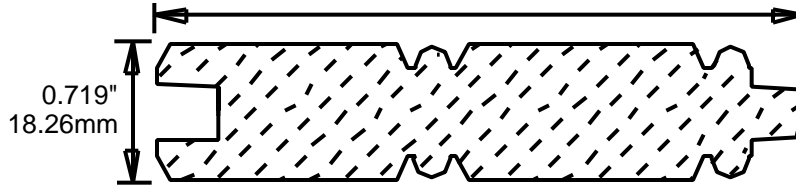

PT7151PR1

5.375"  
136.53mm

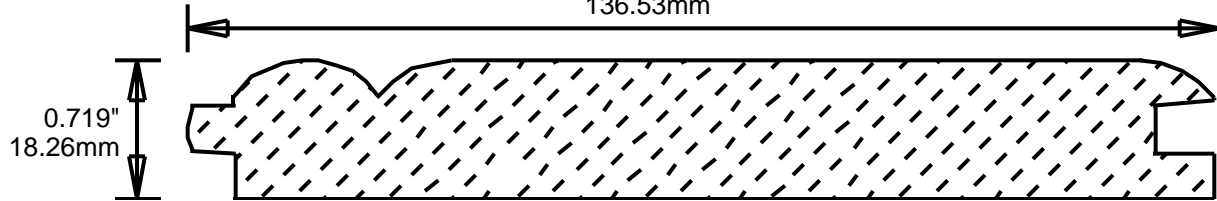

PT7151RR1

5.375"  
136.53mm

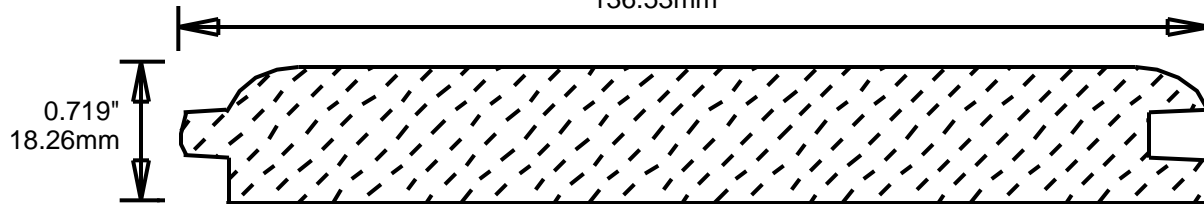

PT7151V01

5.375"  
136.53mm

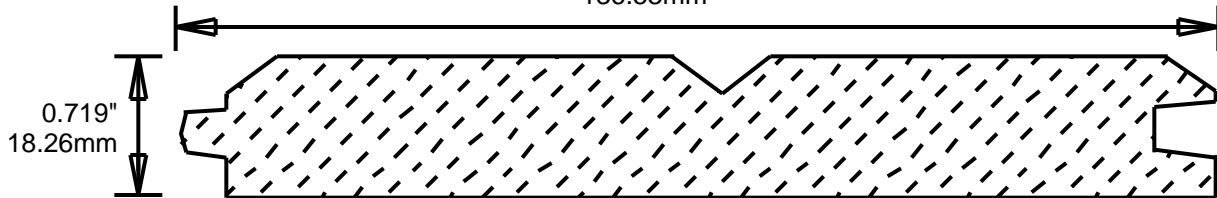

PT7153BV1

5.375"  
136.53mm

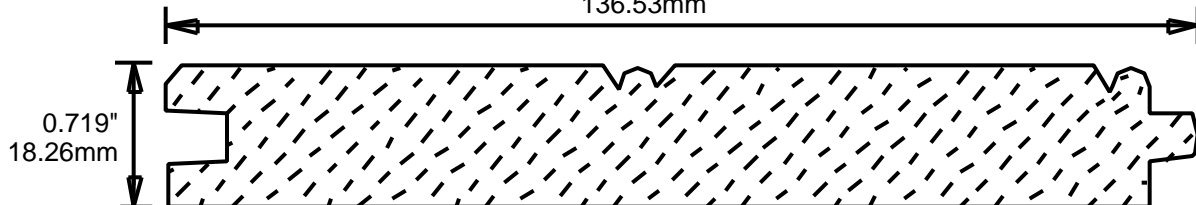

PT7160VV1

6" or 8"  
152.40mm 203.20mm

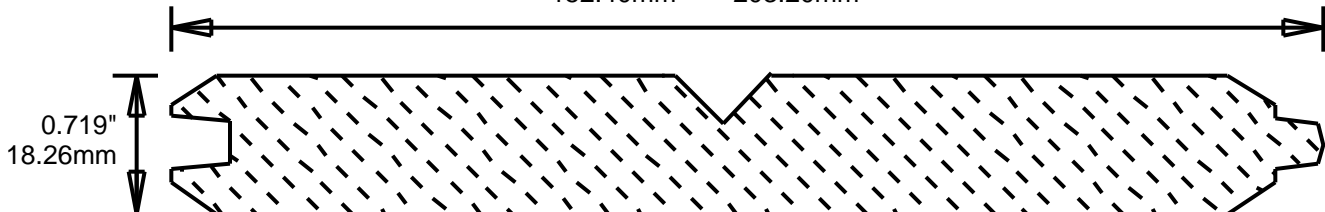

**PRINT  
THIS SECTION**

**RETURN TO  
Table of Contents**



# WEINIG TONGUE-AND-GROOVE PATTERNS

PT7168B01

7.125"  
180.98mm

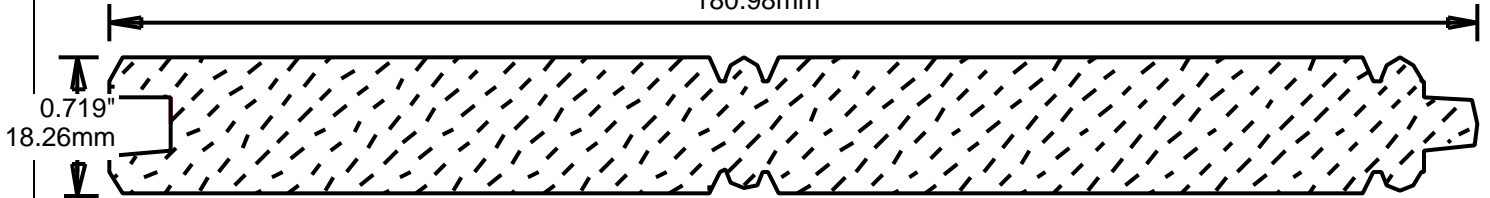

PT7180VV1

8"  
203.20mm

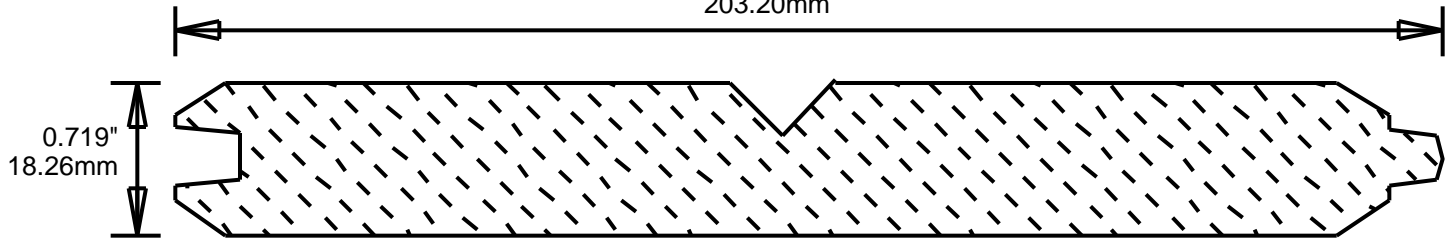

Not to Scale

PT7500001

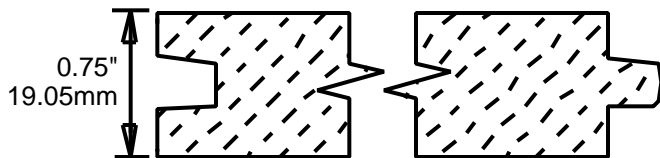

PT7500002

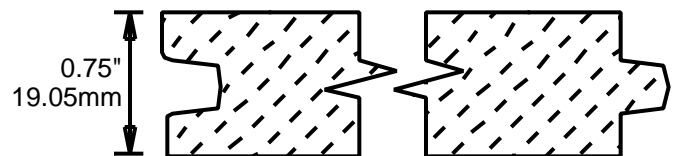

PT7500003

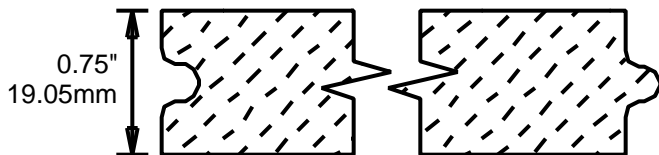

PT7500N01

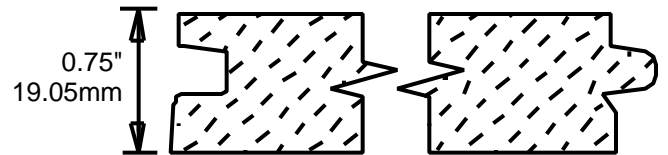

PT7500N03

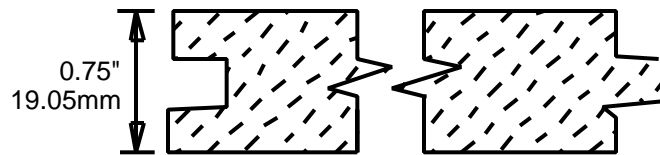

PT7500NR1

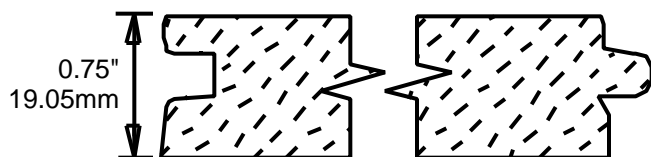

PT7500RR1

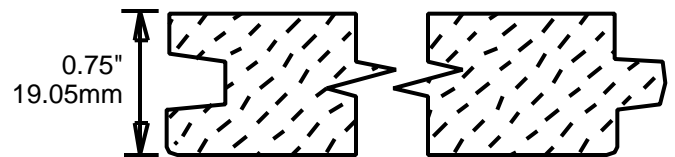

# WEINIG TONGUE-AND-GROOVE PATTERNS

PT7500V01

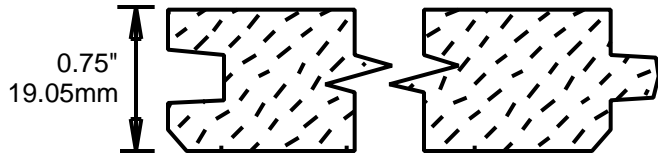

PT7500V02

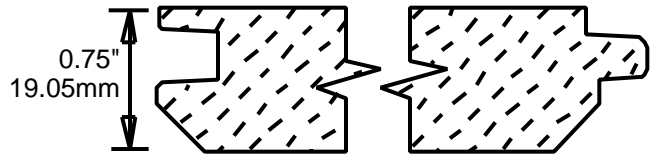

PT7500V03

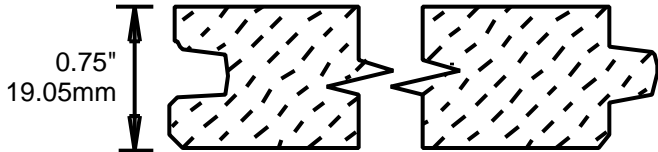

PT7500V04

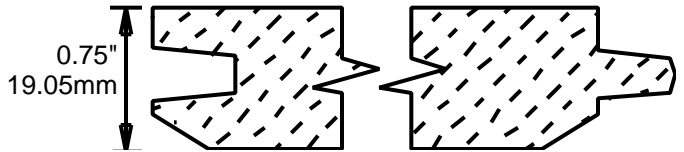

PT7500VN2

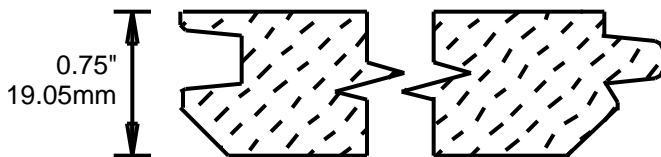

PT7500VN3

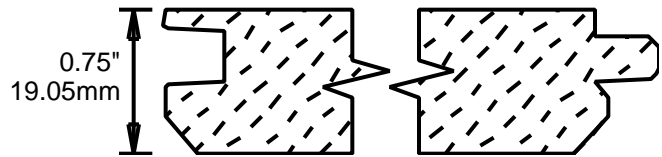

PT7500VV1

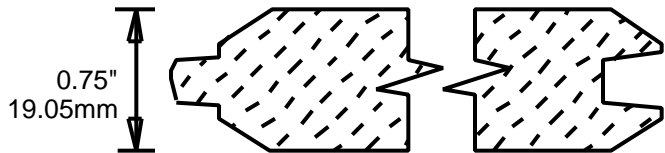

PT7500VV2

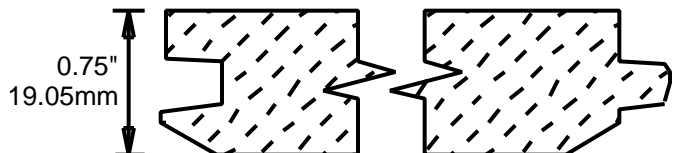

PT7500VV3

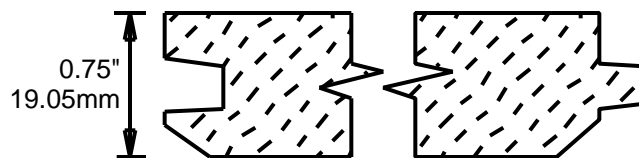

PT7531BV1

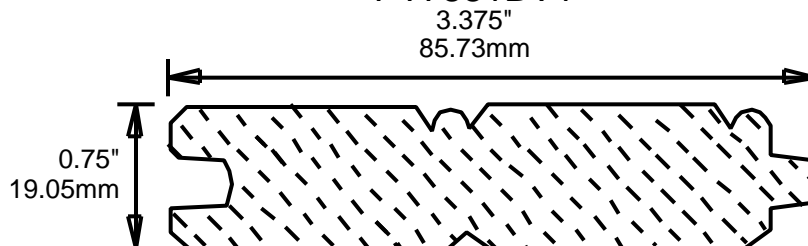

# WEINIG TONGUE-AND-GROOVE PATTERNS

PT7532PV1

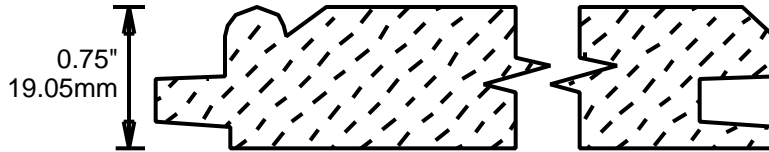

PT7536PV1

3.687"  
93.65mm

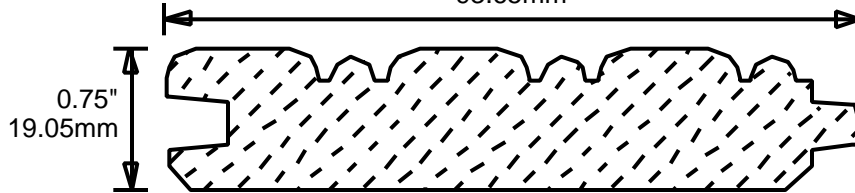

PT7551VV2

5.437"  
138.10mm

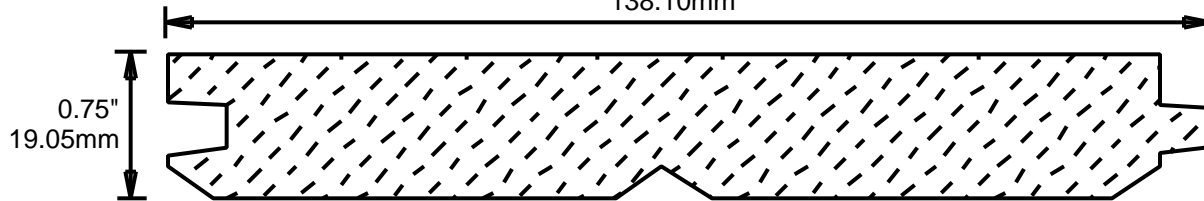

PT7553BV1

5.375"  
136.53mm

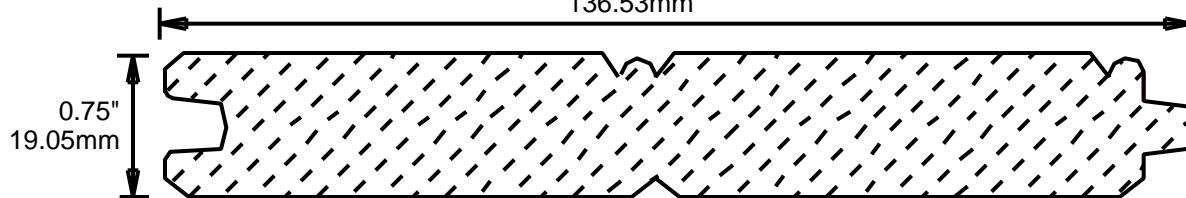

PT7800N01

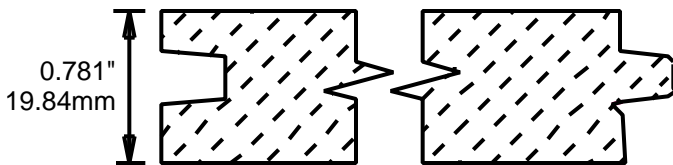

PT8700001

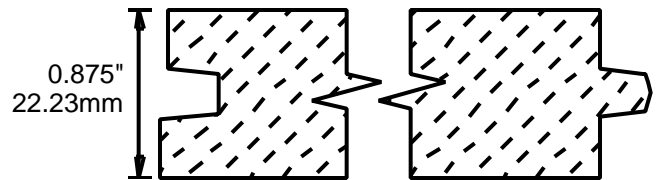

PT9300001

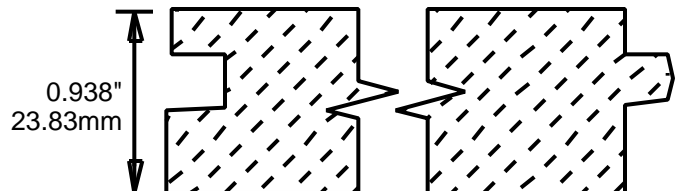

PS1071V01

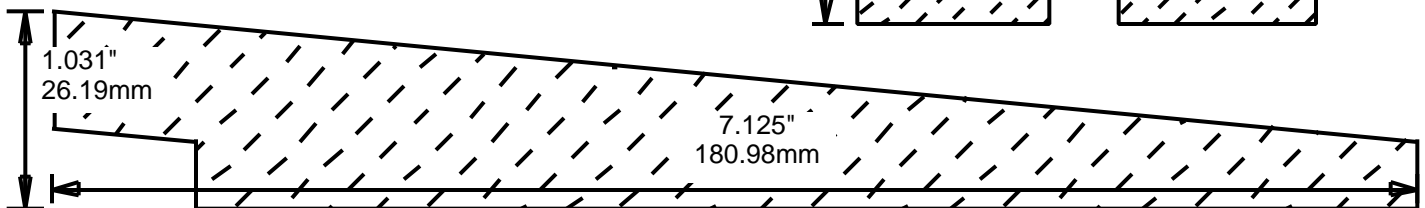

# WEINIG TONGUE-AND-GROOVE PATTERNS

PS1470PV1

SHIPLAP

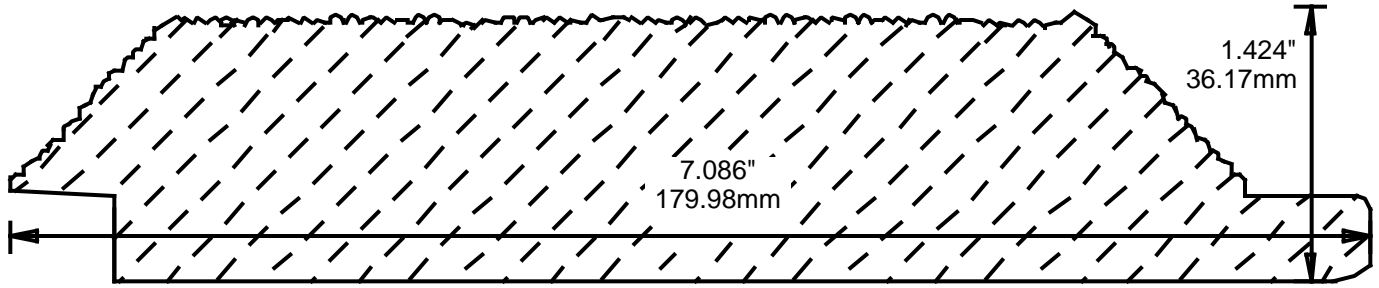

PS1500001

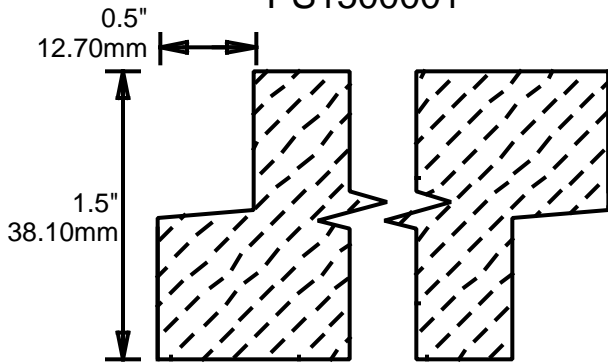

PS1542R01

4.25"  
107.95mm

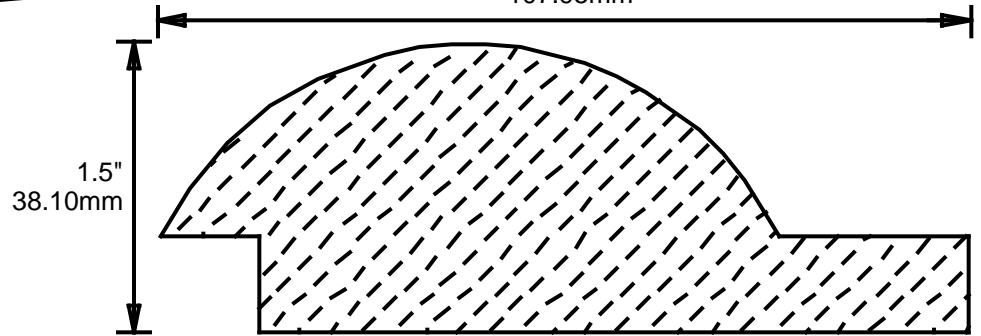

PS1554R01

5.437"  
138.10mm

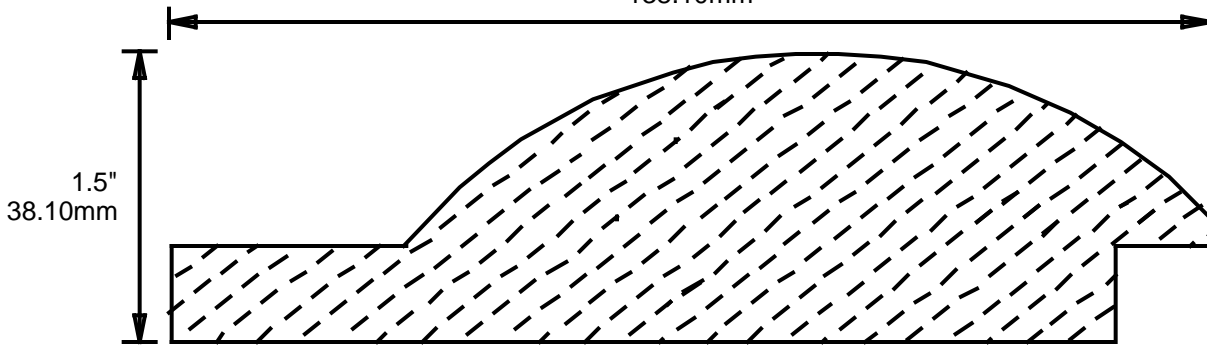

PS1566P01

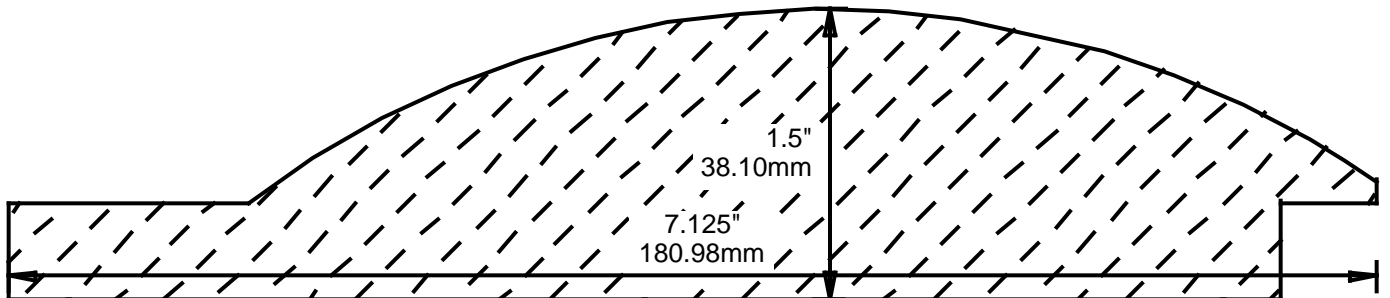

# WEINIG TONGUE-AND-GROOVE PATTERNS

## SHIPLAP

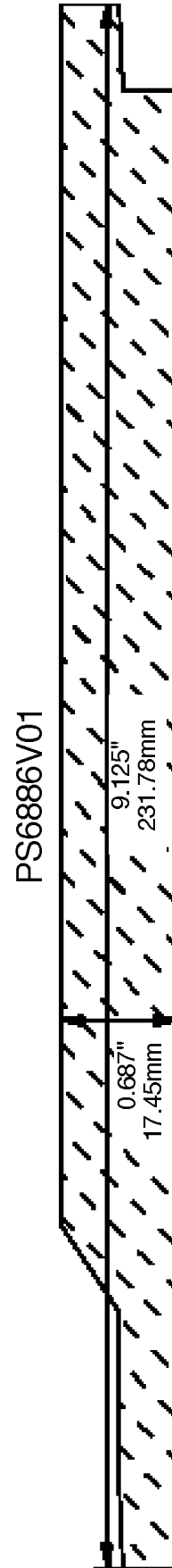
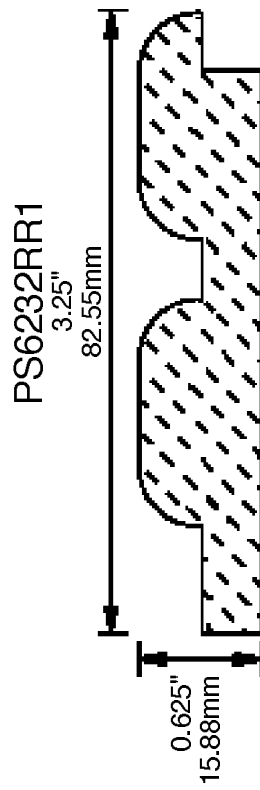
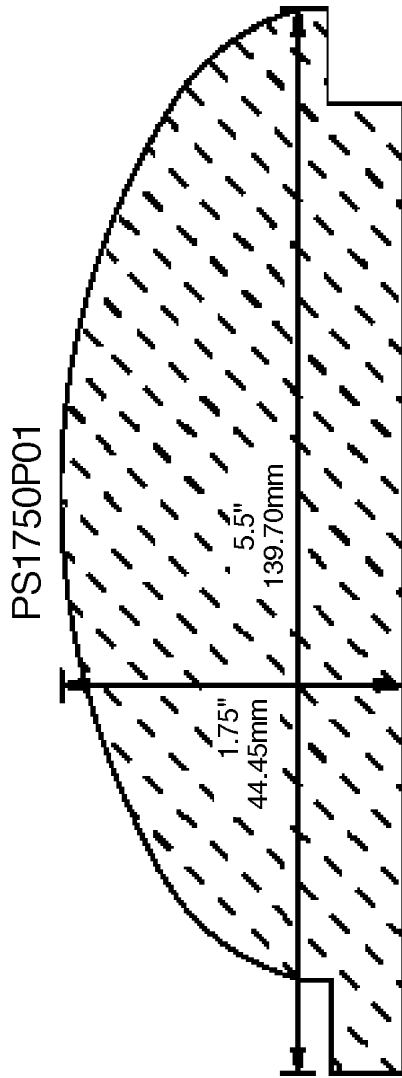

PS7100001

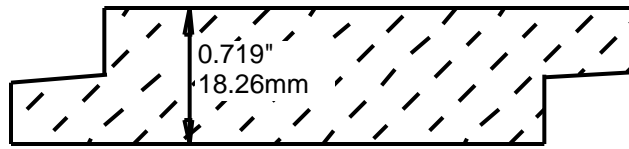

PS7150P01

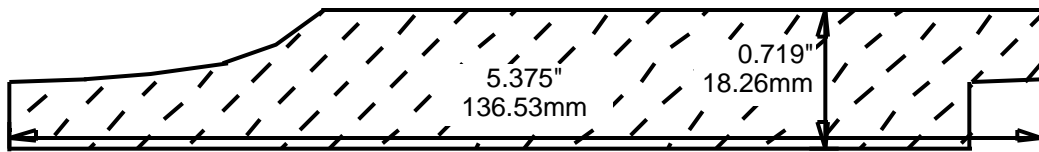

PT7150PP1

5.375"  
136.53mm

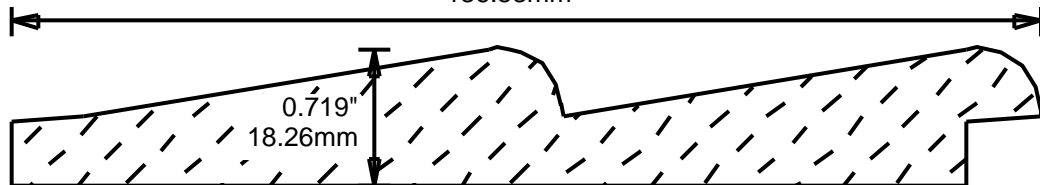

PS7151VV1

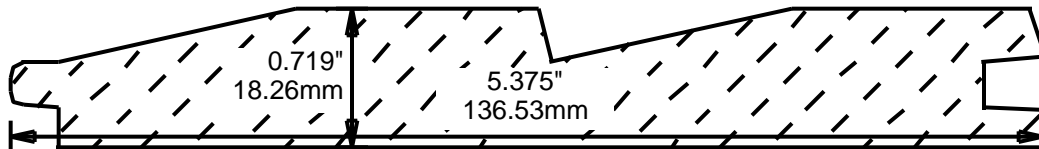

PS7153RP1

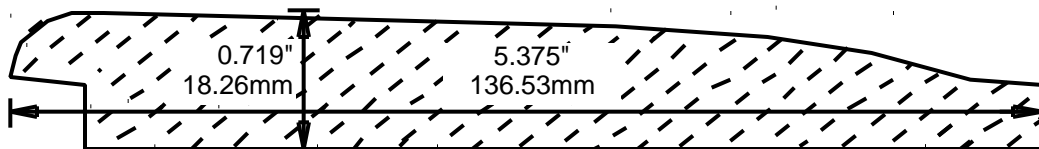

PS7154RR1

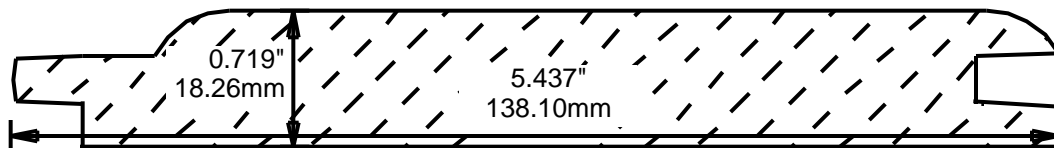

PS7154RR2

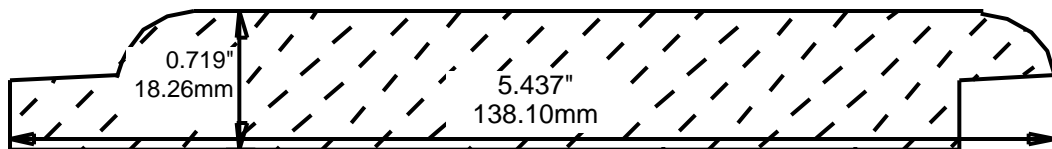

# WEINIG TONGUE-AND-GROOVE PATTERNS

## SHIPLAP

PS7166P01

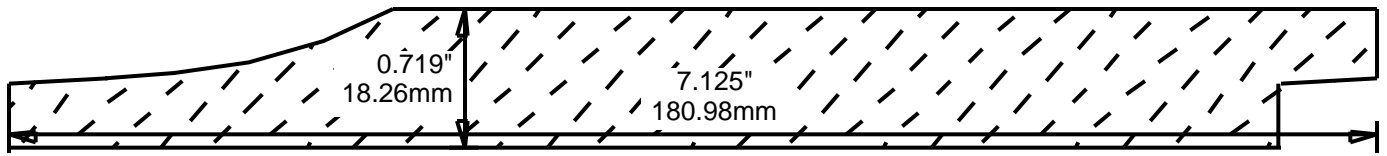

PS7166P02

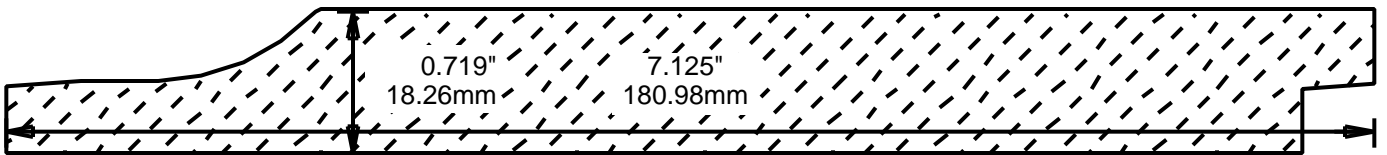

PS7167V01

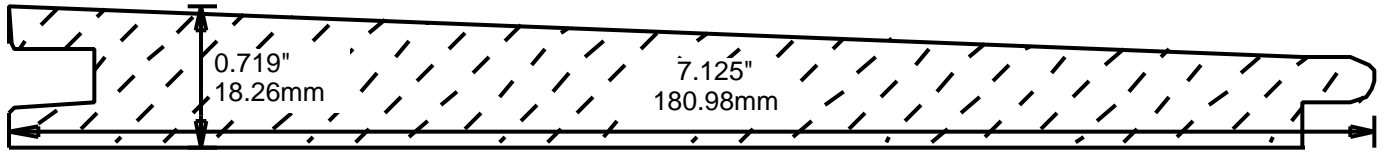

PS7171RR1

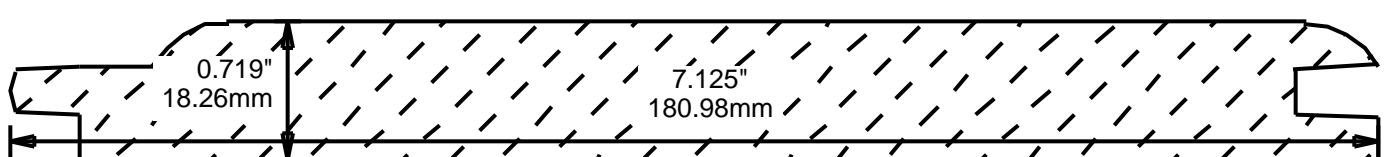

PS7171RR2

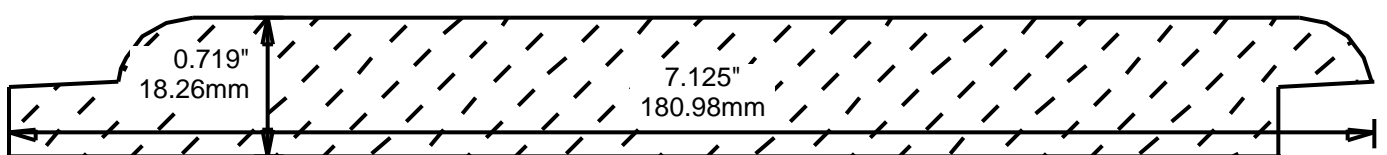

PS7171VV1

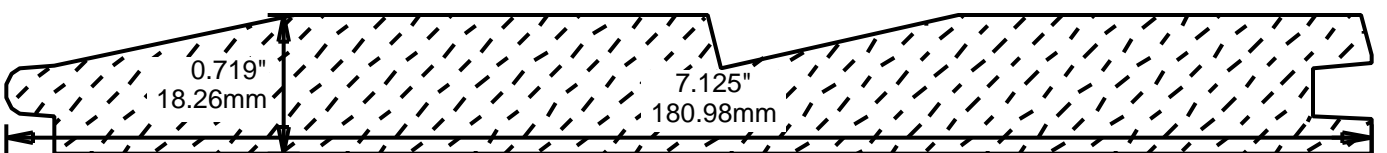

PS7175V01

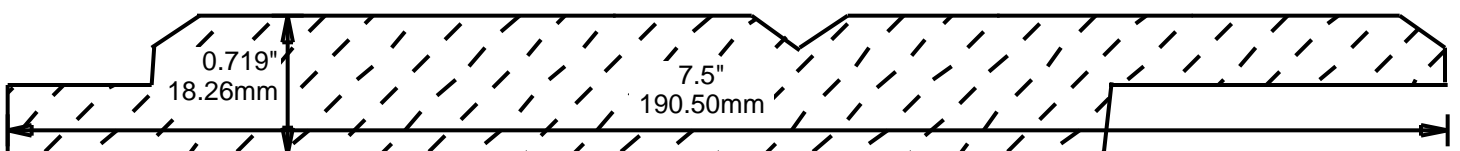

PS7180P01

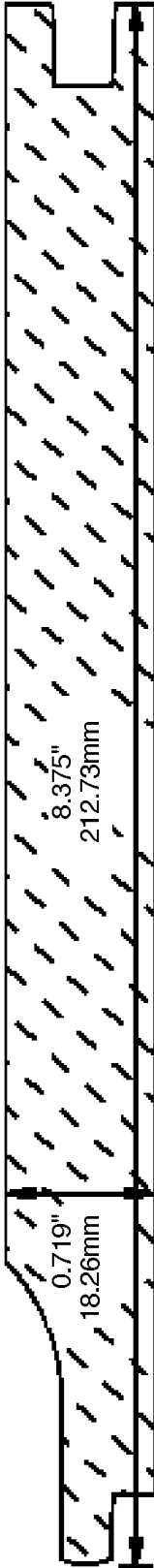

PS7190P01



PS7500V01

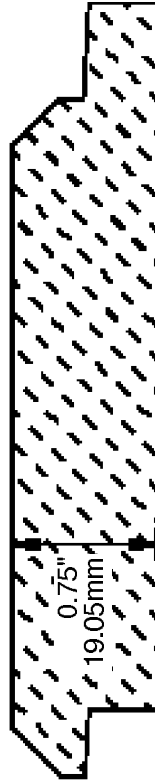

PS9050V01

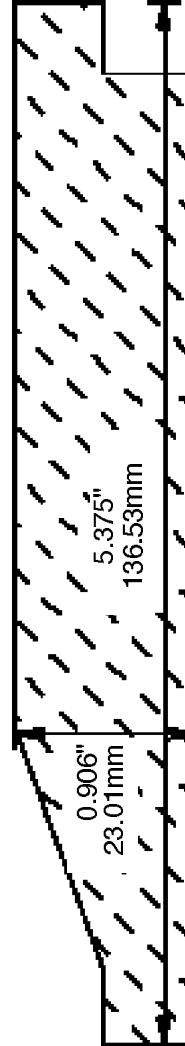



# WEINIG OUTSIDE CORNERS

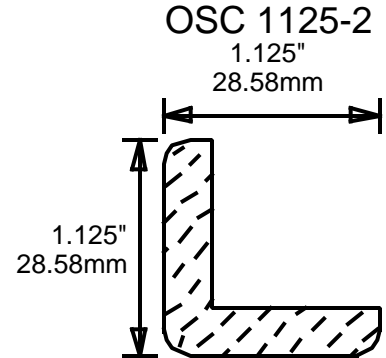
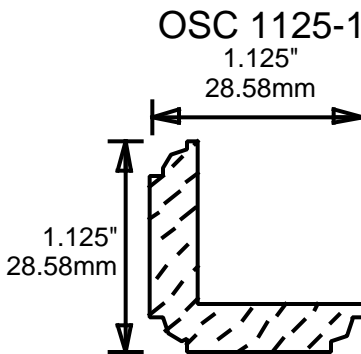
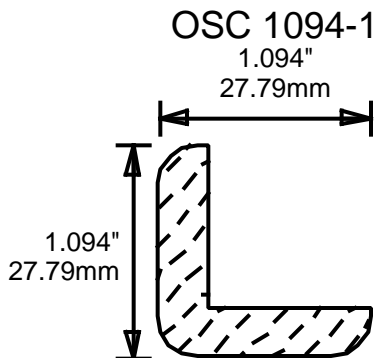
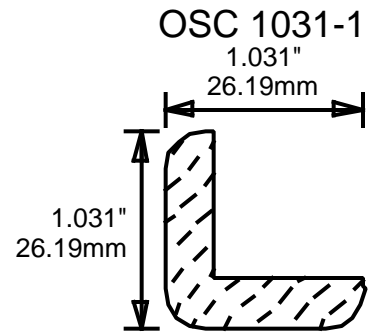
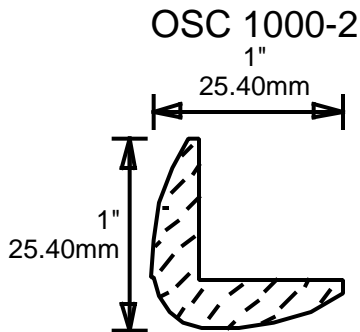
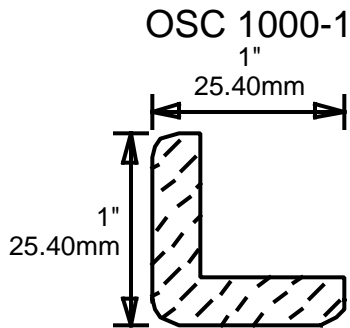
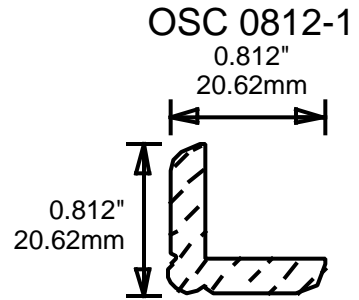
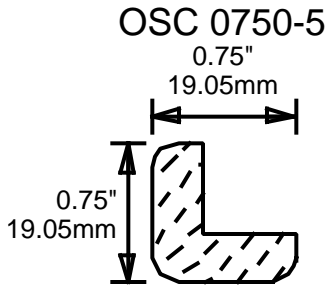
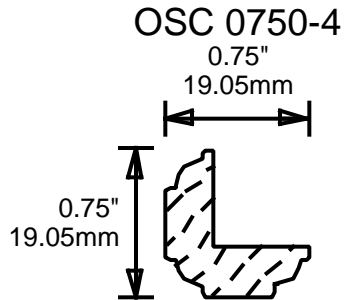
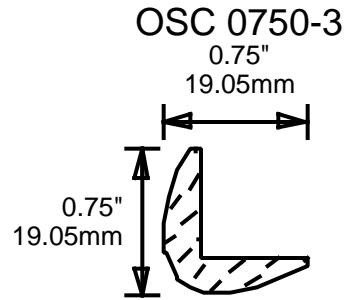
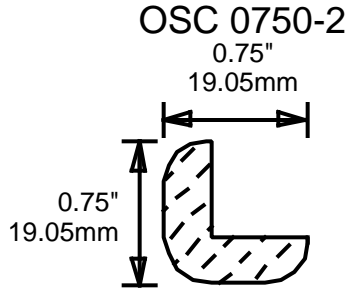
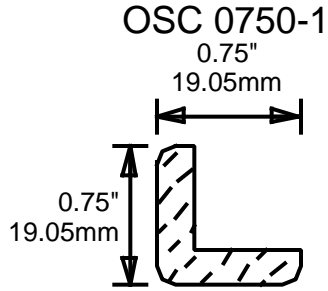

# WEINIG OUTSIDE CORNERS

OSC 1250-1

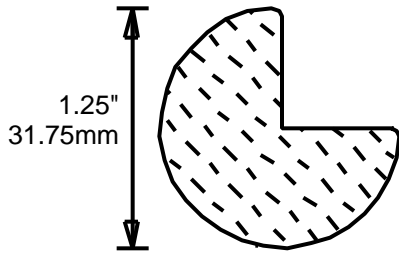

OSC 1250-2

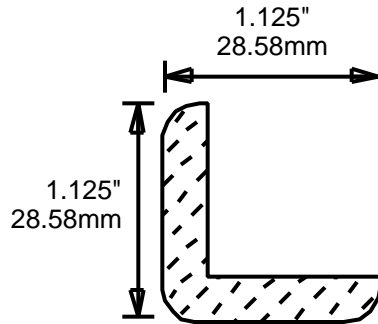

OSC 1312-1

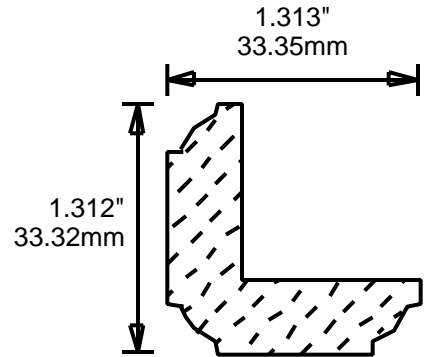

OSC 1312-2

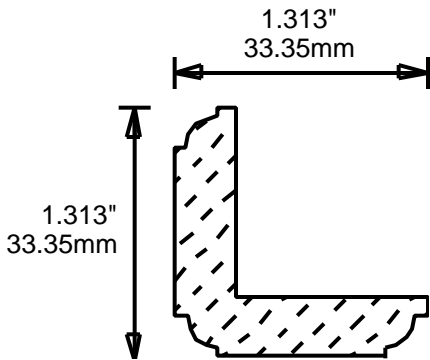

OSC 1312-3

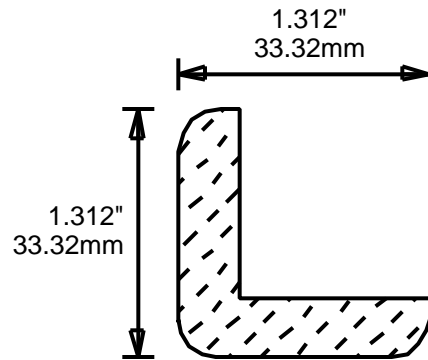

OSC 1437-1

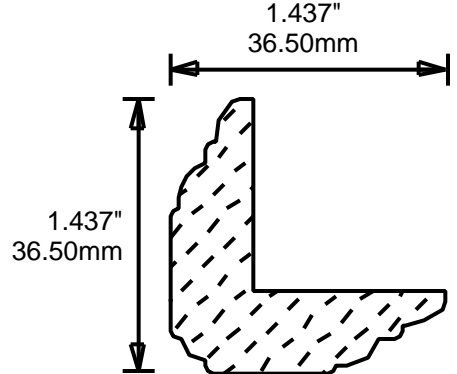

OSC 1437-2

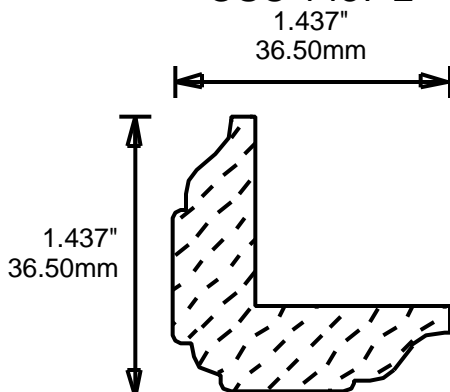

OSC 1500-1

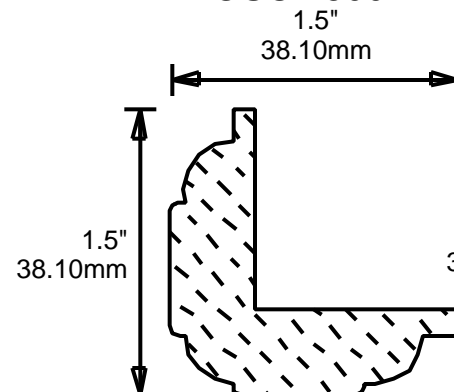

OSC 1500-2

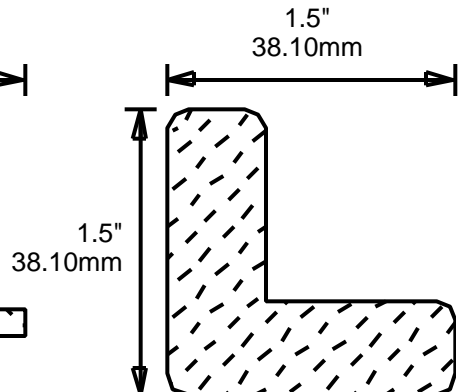

KEN 5001

0.5"  
12.70mm

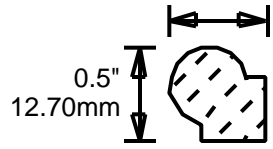

KEN 6251

0.625"  
15.88mm

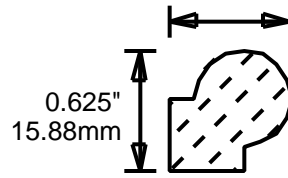

KEN 7501

0.75"  
19.05mm

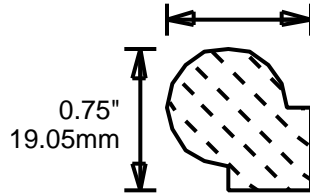

KEN 9371

0.937"  
23.80mm

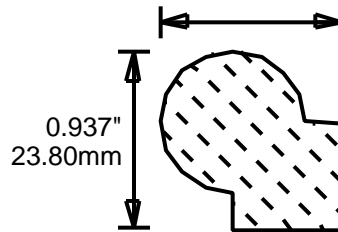

# WEINIG DRIP CAPS

WR1  
3"  
76.20mm

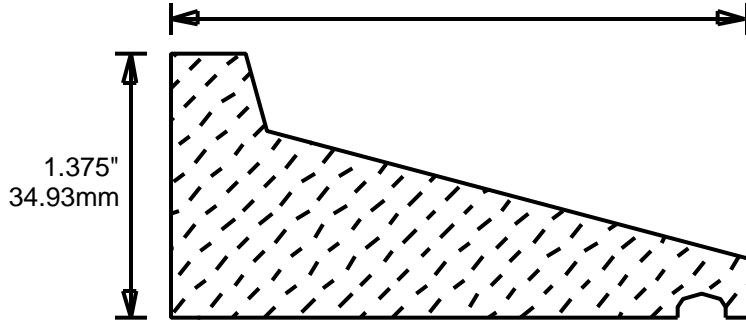

WR2  
2"  
50.80mm

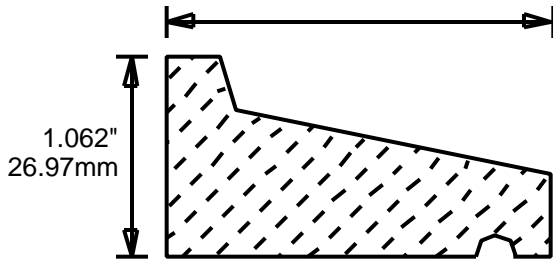

WR3  
1.625"  
41.28mm

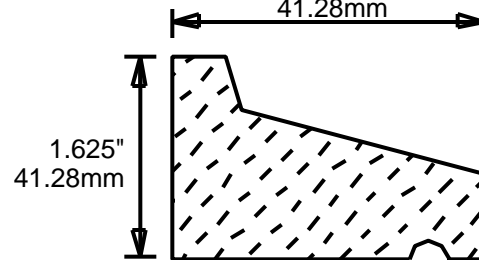

WR4  
1.75"  
44.45mm

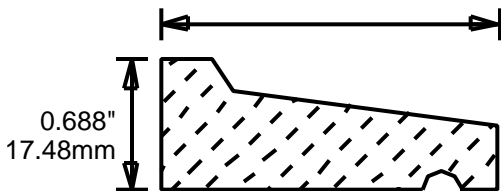

WR5  
1.625"  
41.28mm

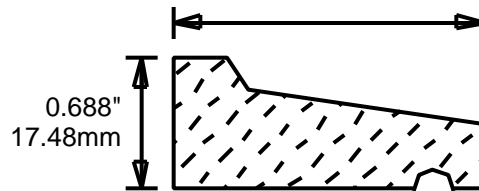

WR6  
2.5"  
63.50mm

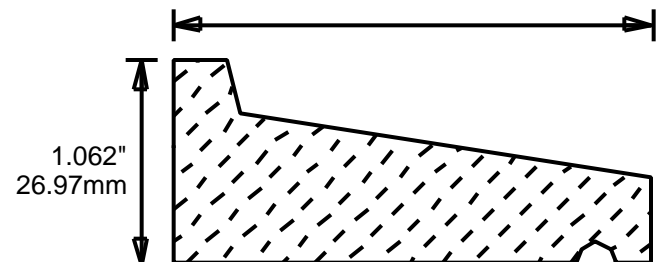

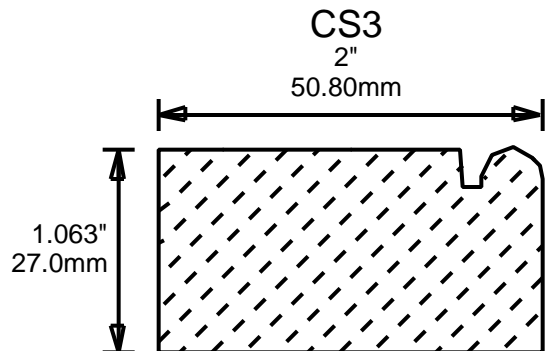
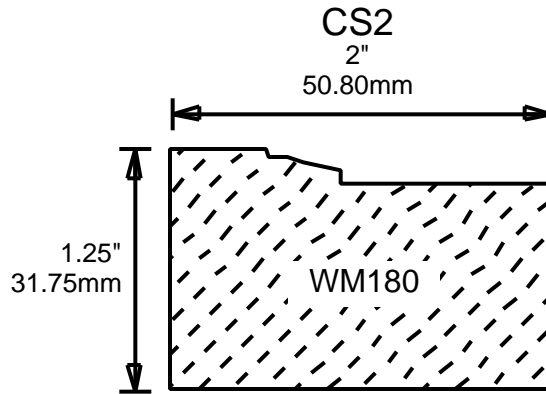
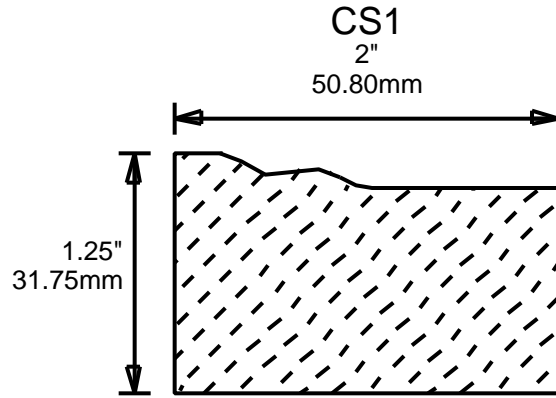

# WEINIG T-ASTRAGALS

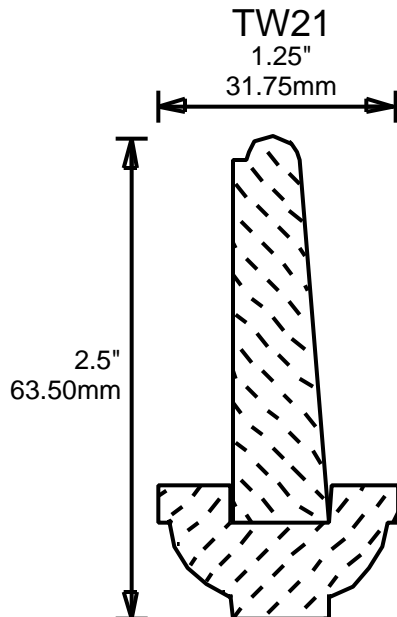
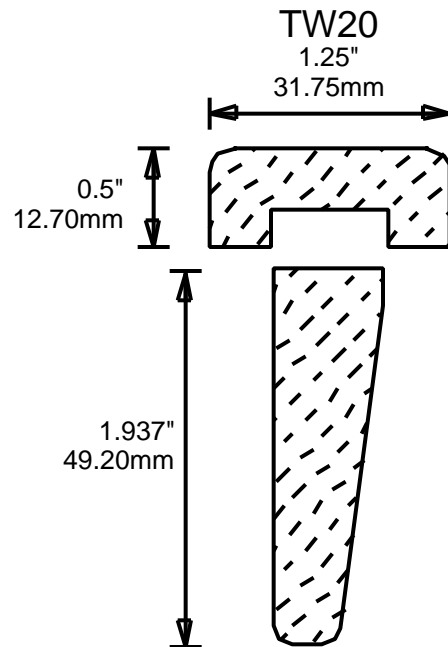
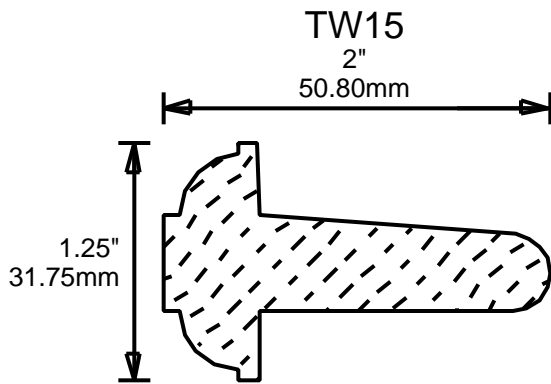
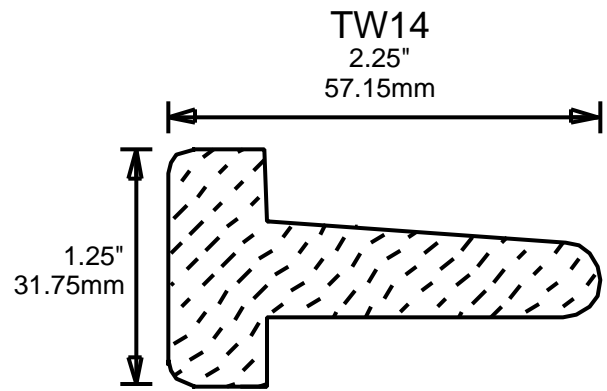
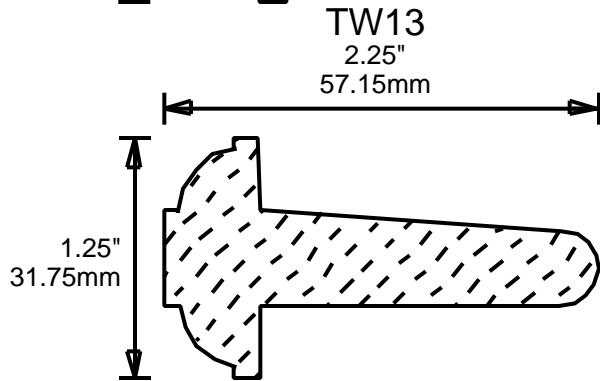
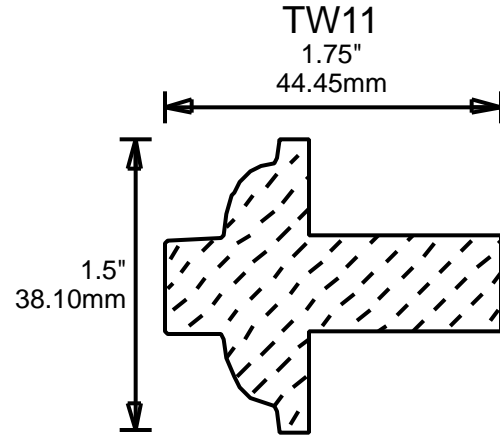
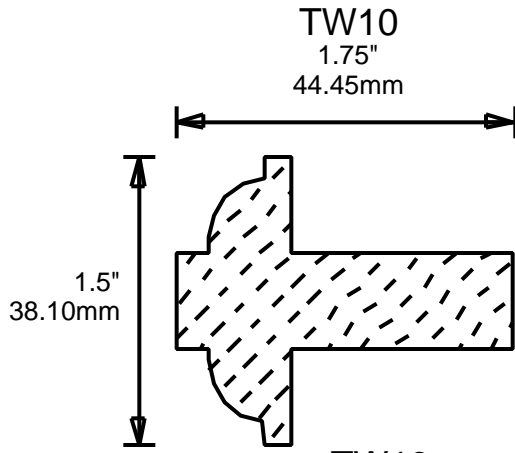

# WEINIG INSIDE CORNERS

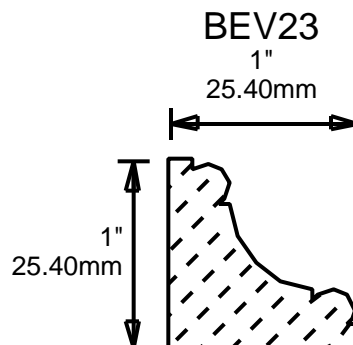
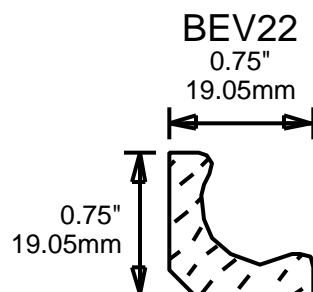
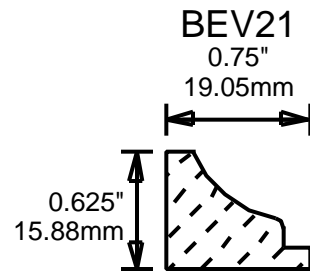
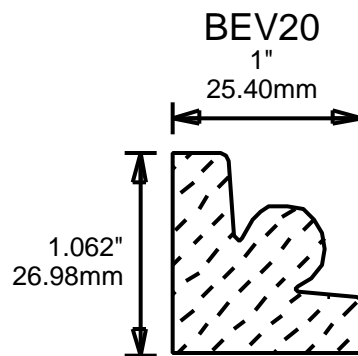
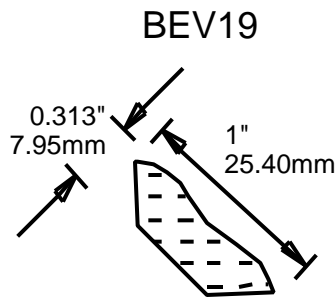
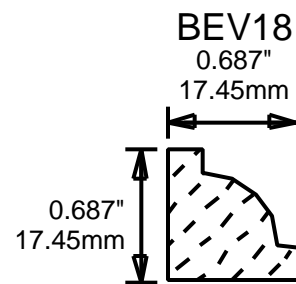
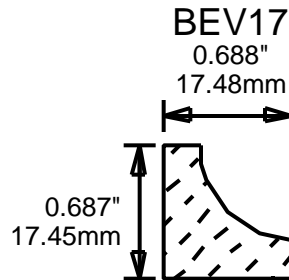
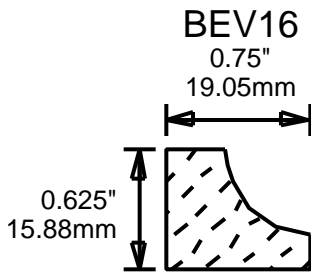
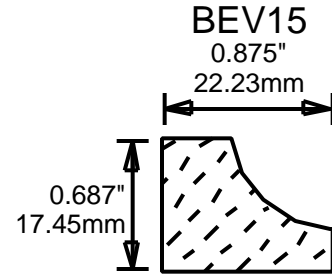
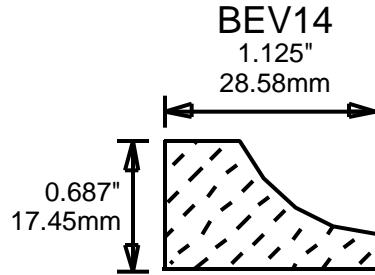
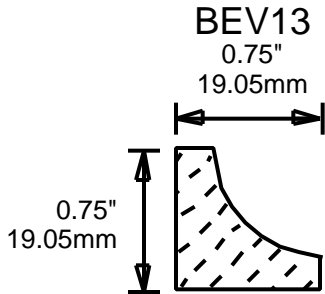
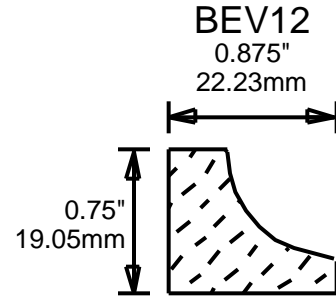
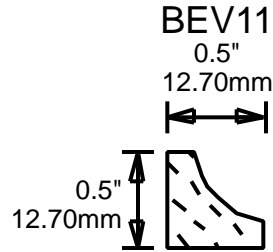
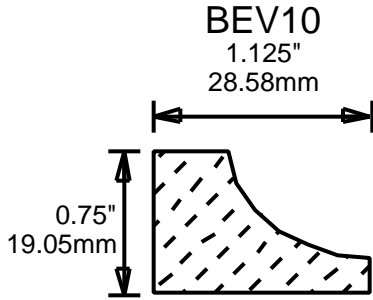

# WEINIG BASE SHOES

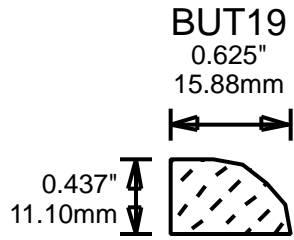
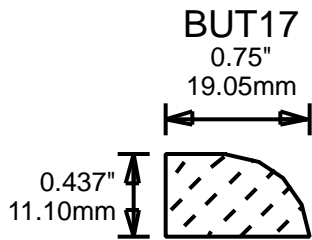
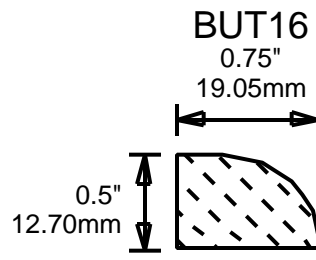
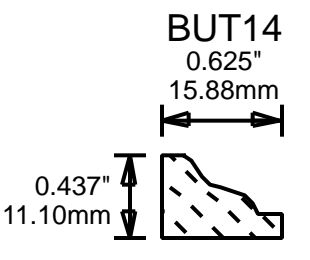
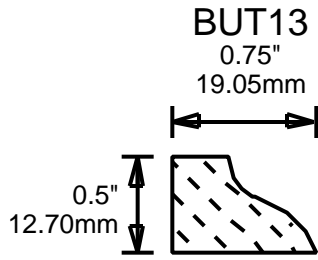
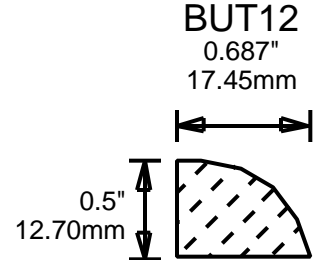
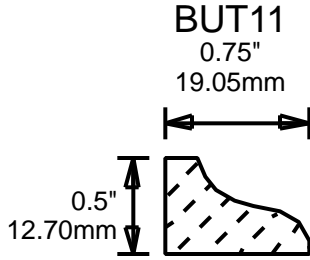
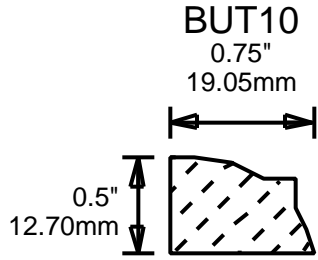



MOM3751



MOM3752



MOM3753

2.25"  
57.15mm

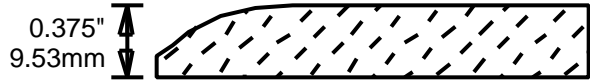

MOM3755

2.25"  
57.15mm

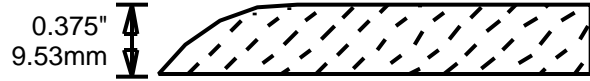

MOM4371



MOM4372

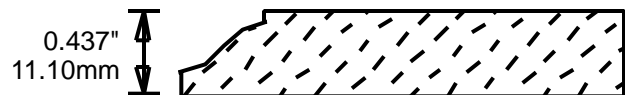

MOM4373



MOM4374

2.25"  
57.15mm

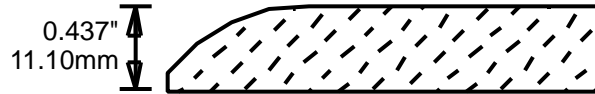

MOM4375

2.25"  
57.15mm



MOM4376

1.375"  
34.93mm



MOM4377

1.375"  
34.93mm



MOM4378

1.375"  
34.93mm



MOM4379

1.375"  
34.93mm



JC10

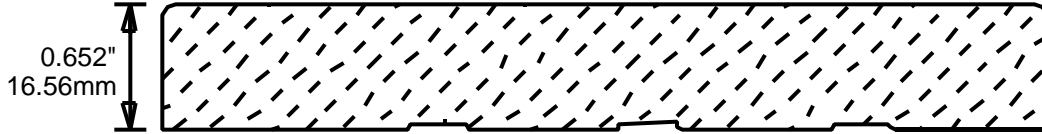

JC11

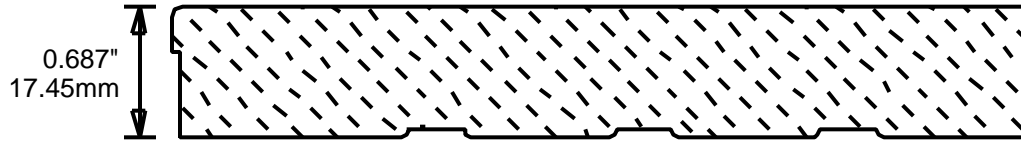

JC12

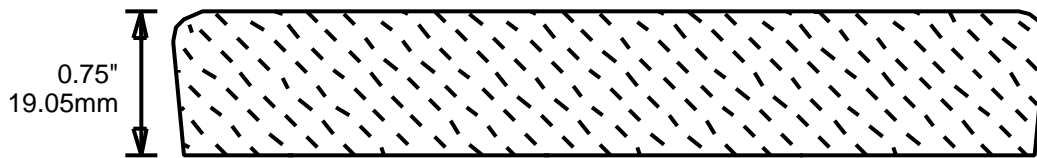

JC13

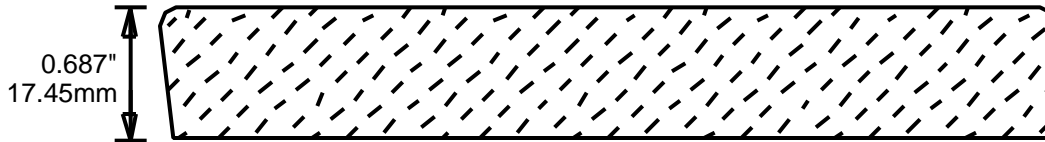

JC15  
6.625"  
168.28mm

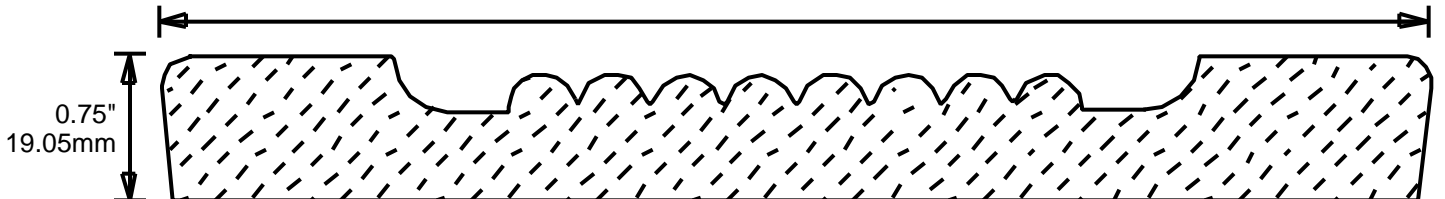

JC20F  
2.75"  
69.85mm

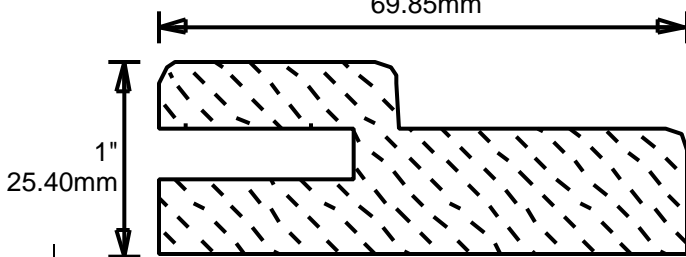

JC20M  
2.875"  
73.03mm

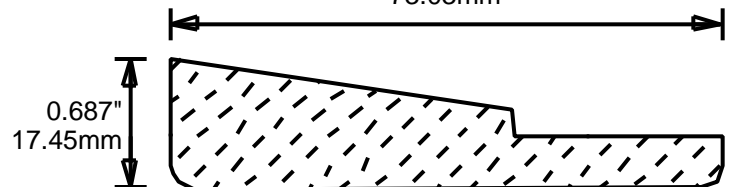

ANGEL 1  
2.219"  
56.36mm

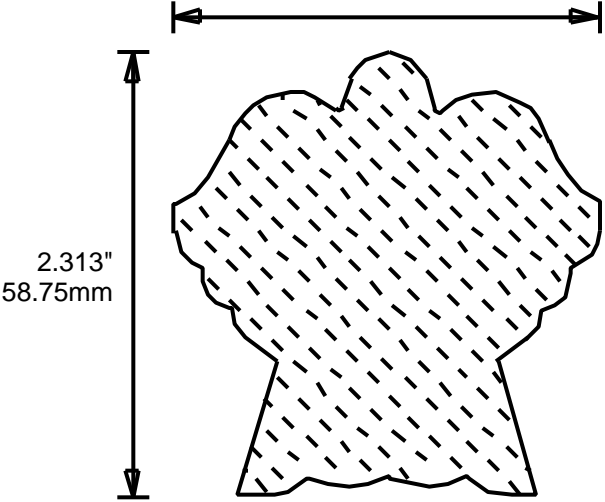

BARN 1  
2.25"  
57.15mm

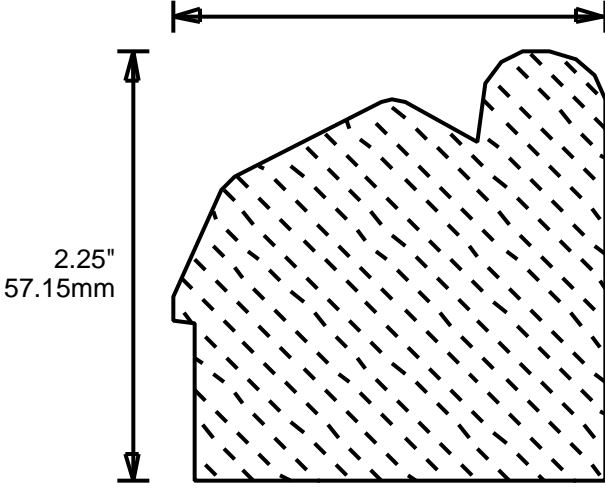

BEAR 1  
1.75"  
44.45mm

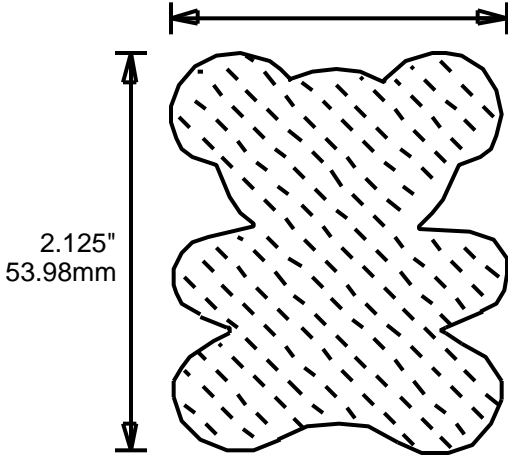

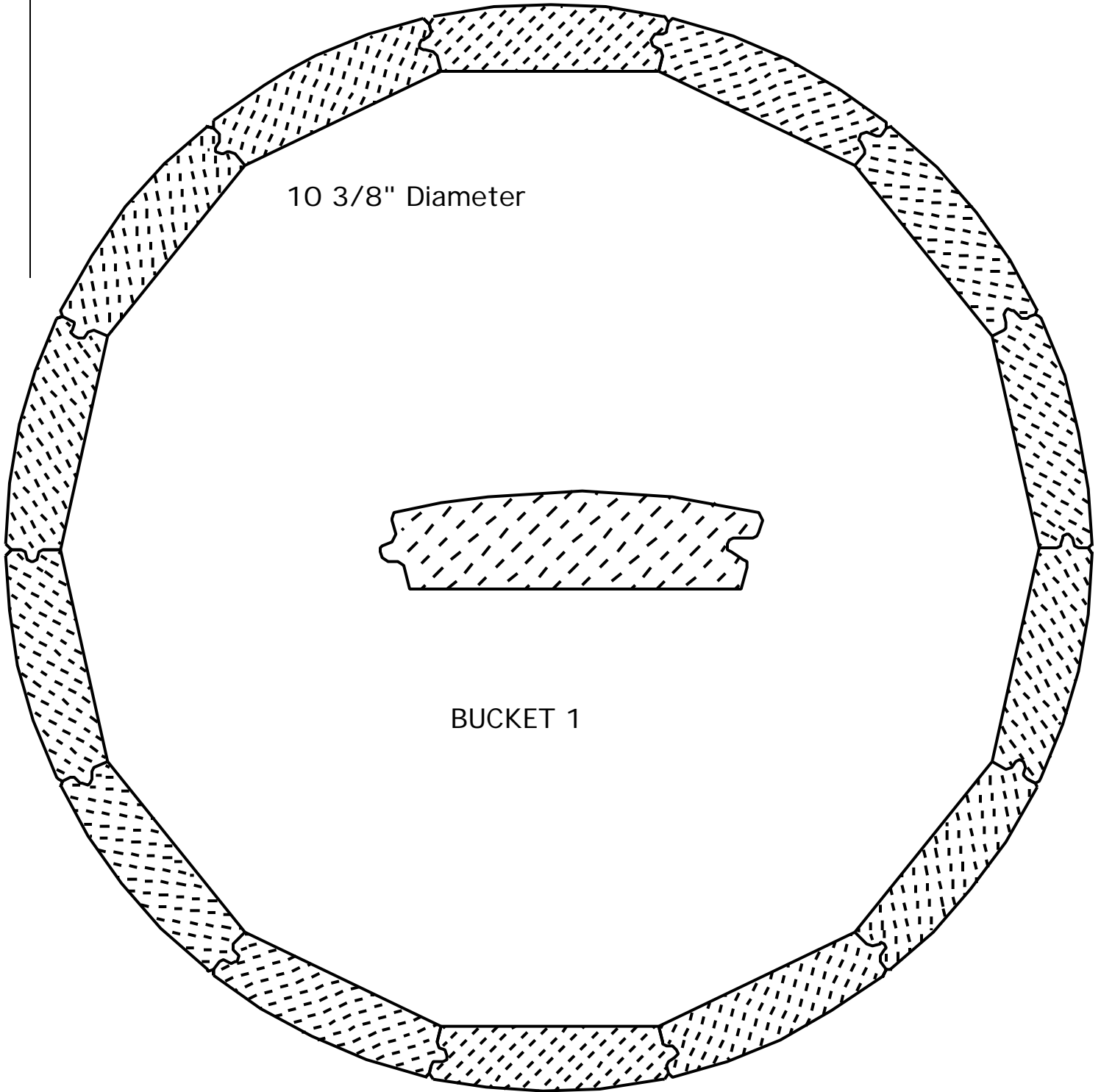

Available in Various Sizes

CAMPFIRE 1

2.5"  
158.75mm

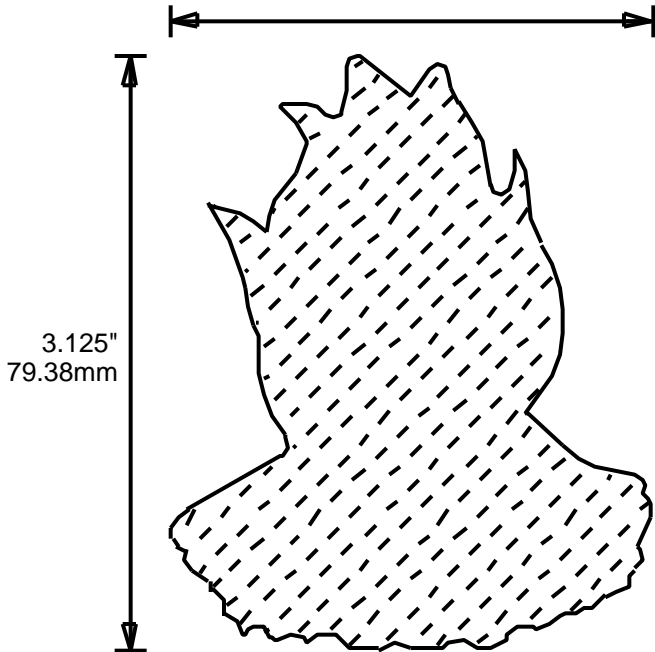

COW 1

2.031"  
51.59mm

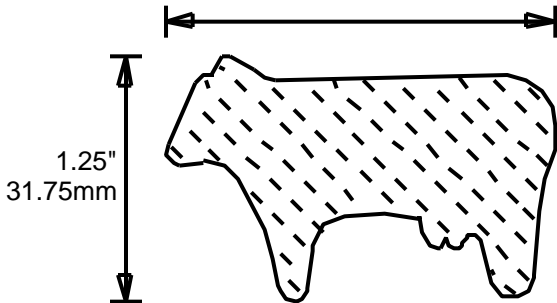

HEART 2

1.181"  
29.997mm

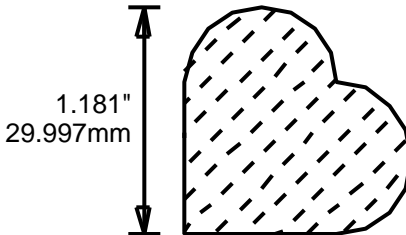

FERRARI 1

3.375"  
85.73mm

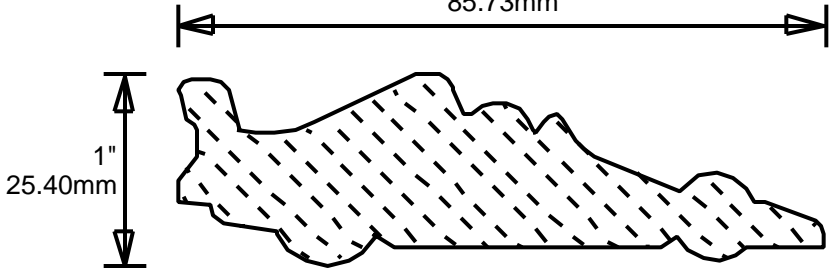

FLAG 1

2.0"  
50.80mm

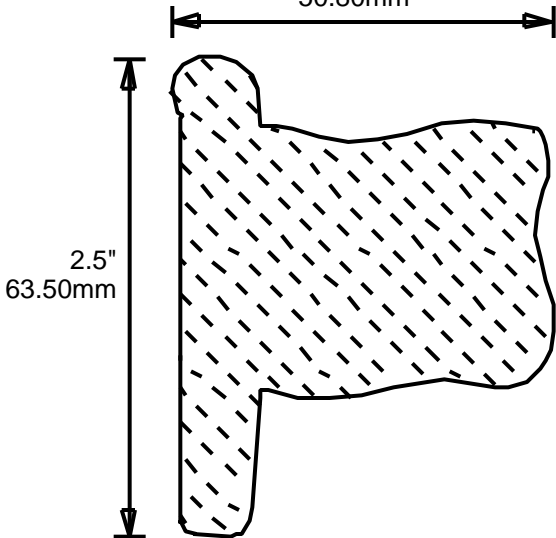

CYCLE 2

3.25"  
82.55mm

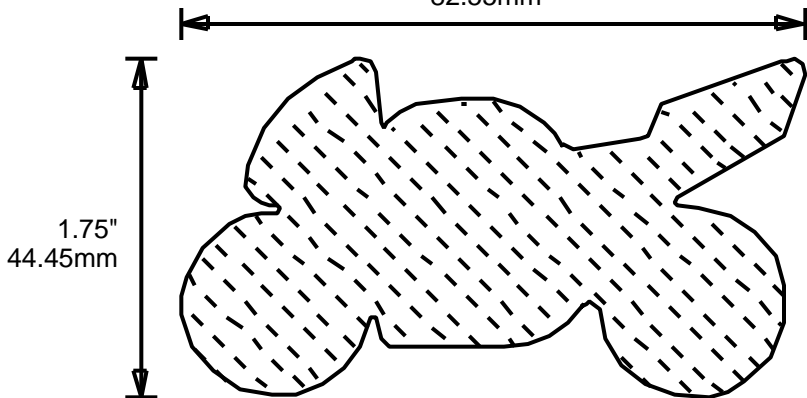

# WEINIG OBJECTS

RABBIT 1

2.312"  
58.72mm

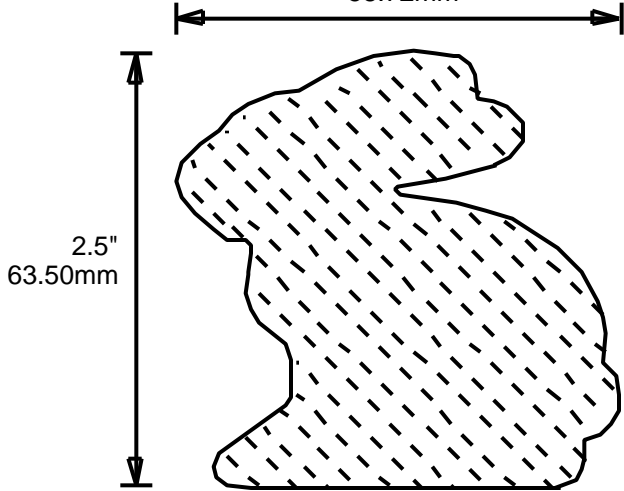

STAR 1

1"  
25.40mm

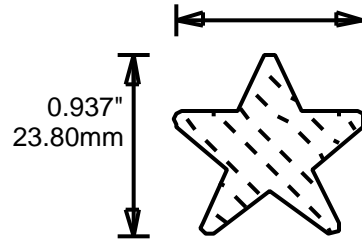

TEXAS 1

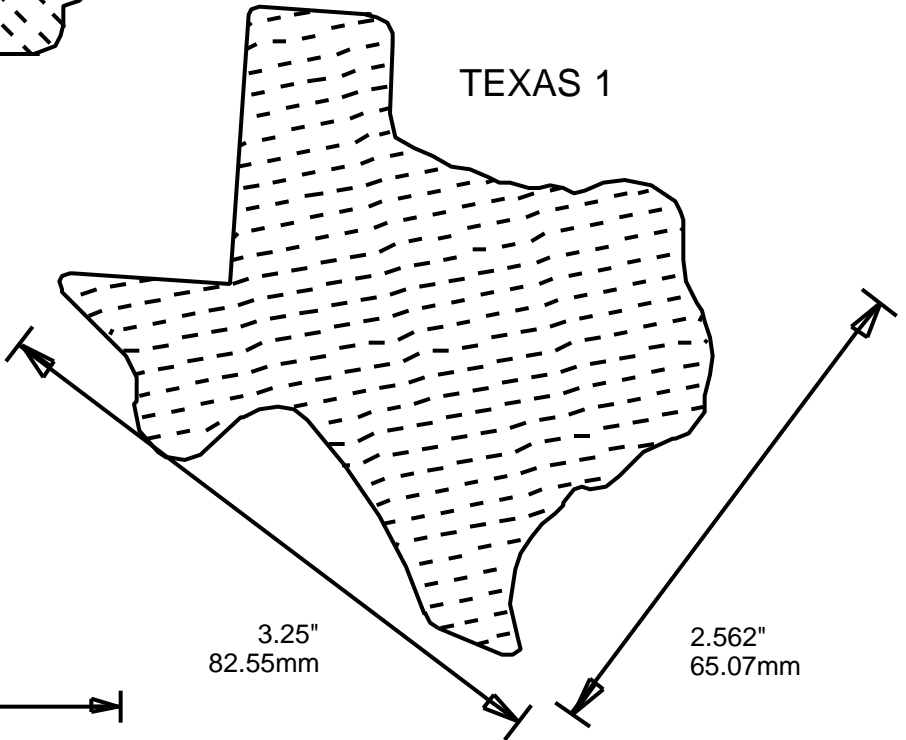

TREE 1

2.313"  
58.75mm

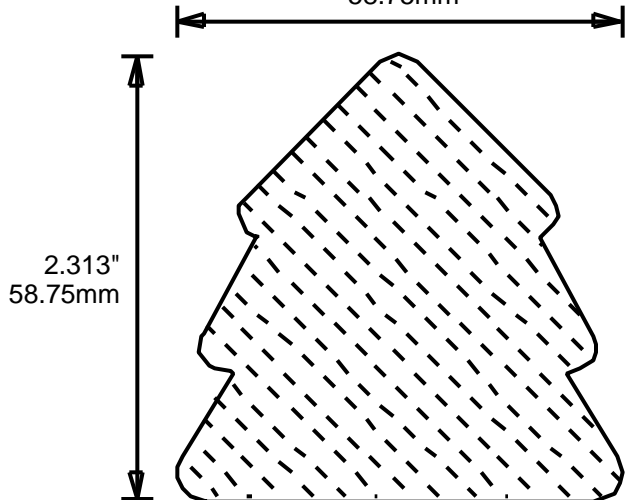

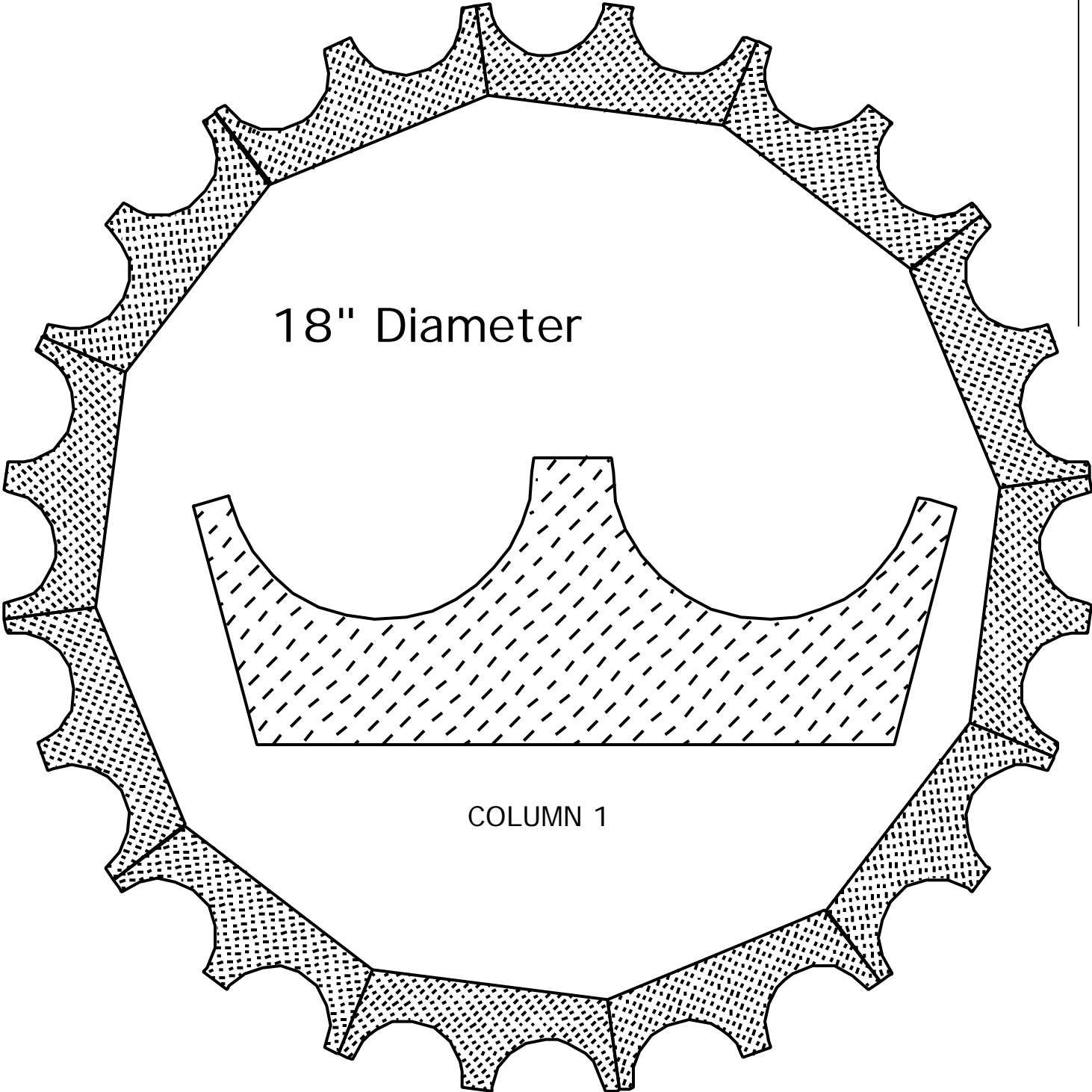

Available in Various Sizes and Styles

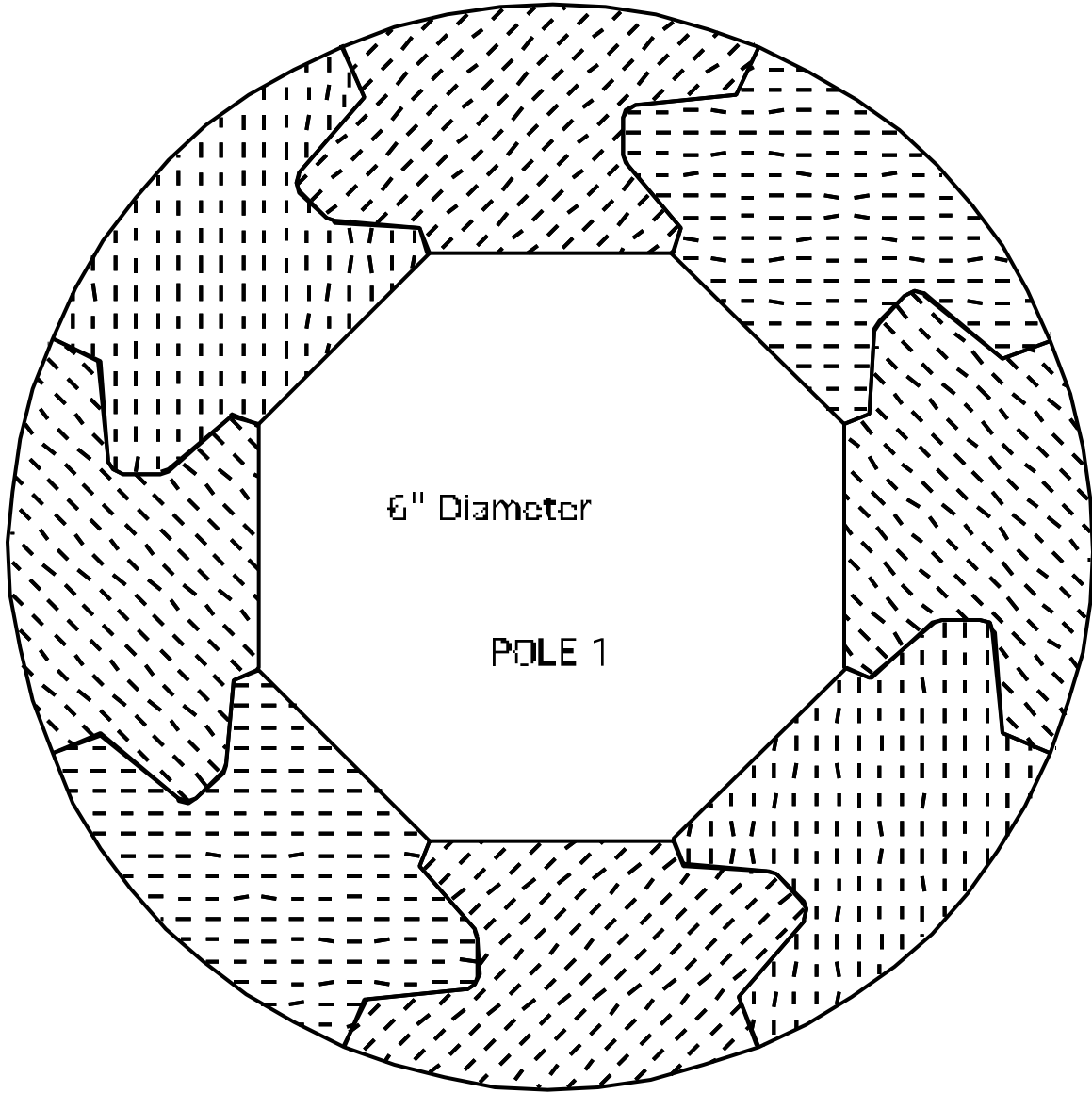

Available in Various Sizes



# WEINIG PICTURE FRAMES

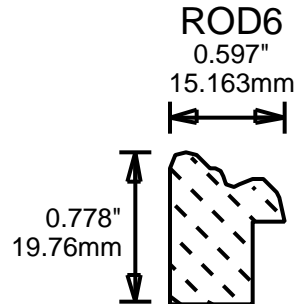
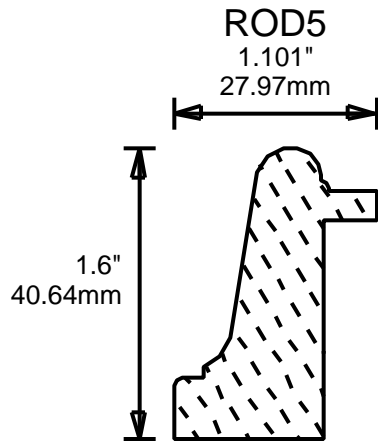
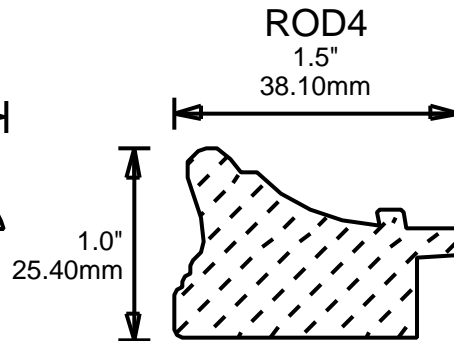
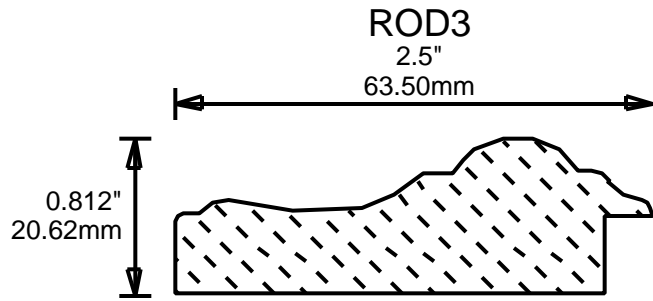
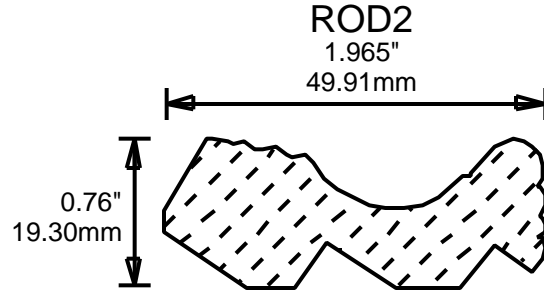
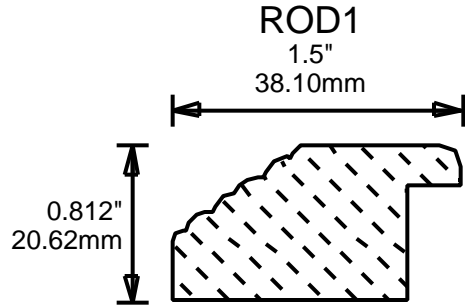

# WEINIG QUARTER ROUNDS

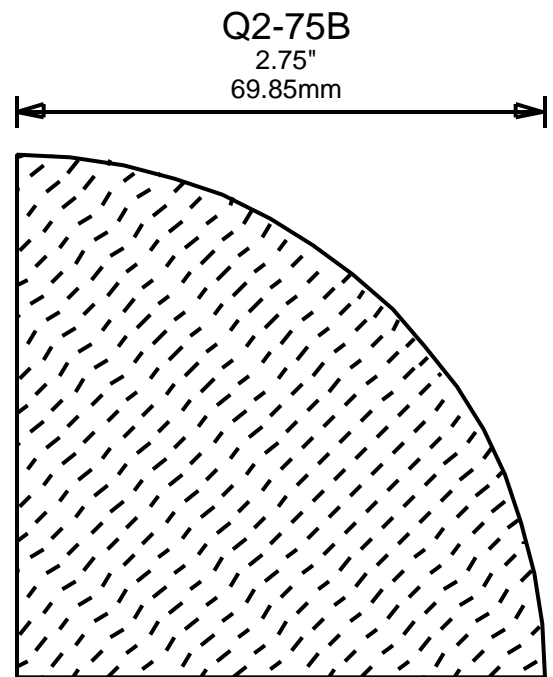
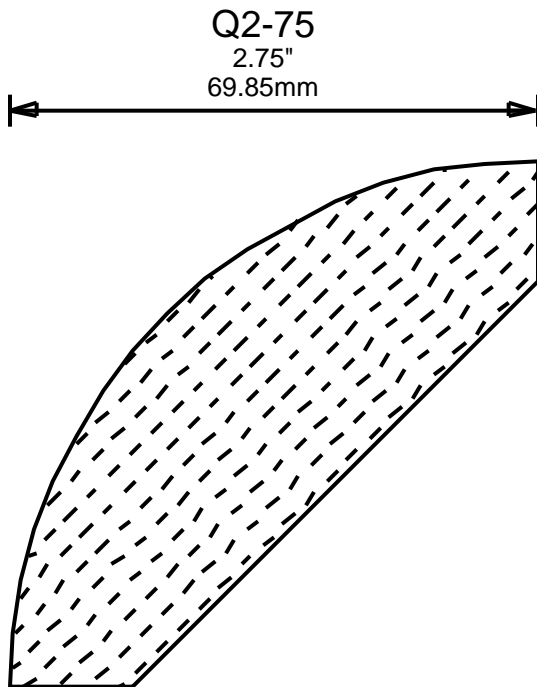
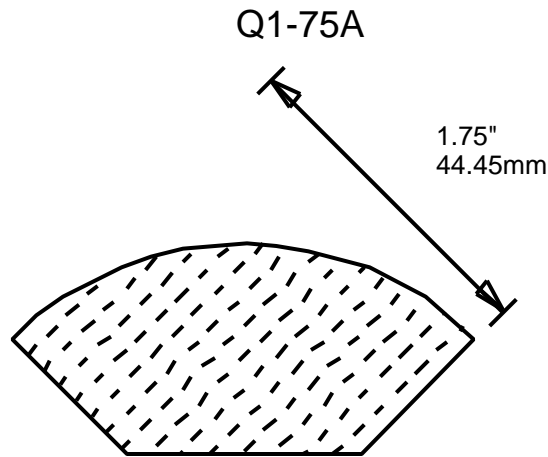
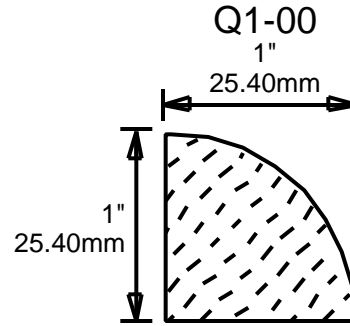
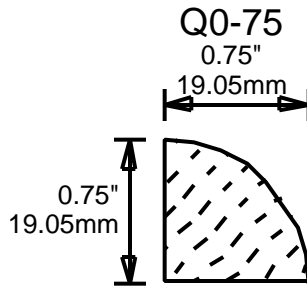

Available in Every Size

# WEINIG HALF ROUNDS & FULL ROUNDS

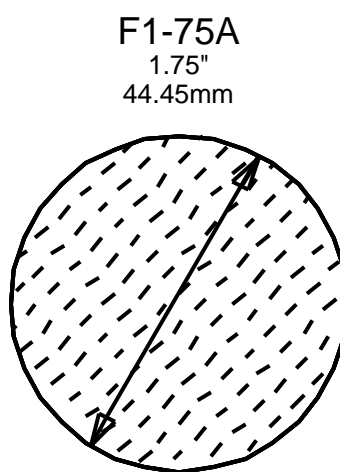
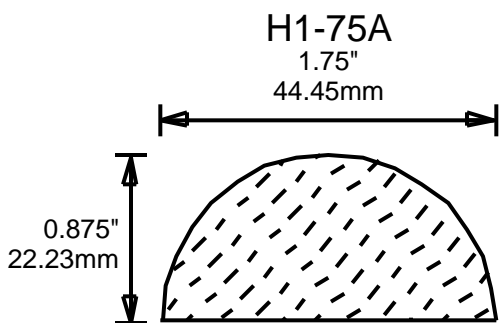
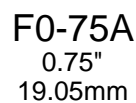
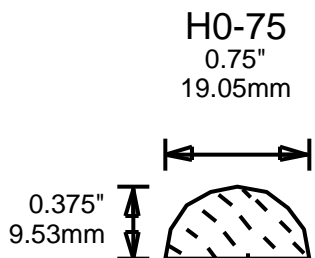
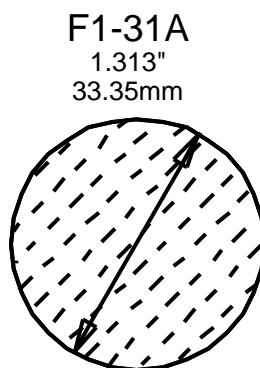
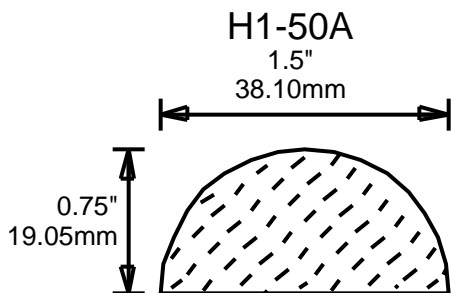
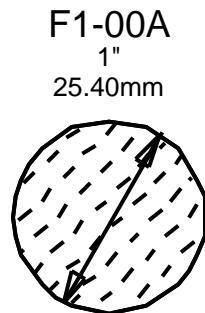
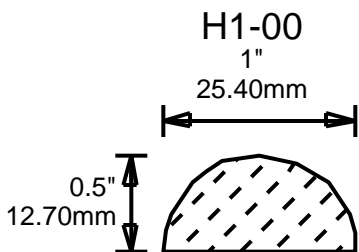

Available in Various Sizes

# WEINIG BULLNOSES

BULL 0500

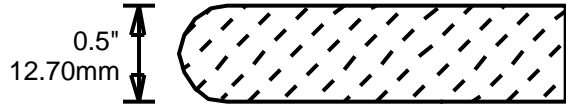

BULL 0750

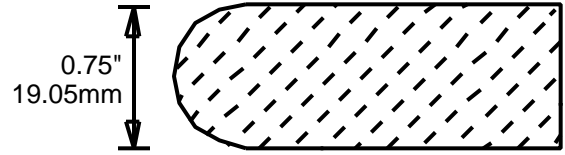

BULL 1000

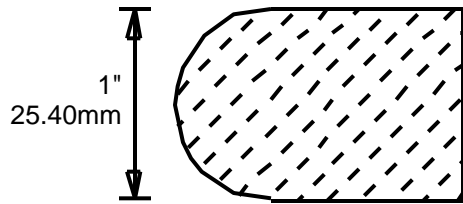

BULL 1312

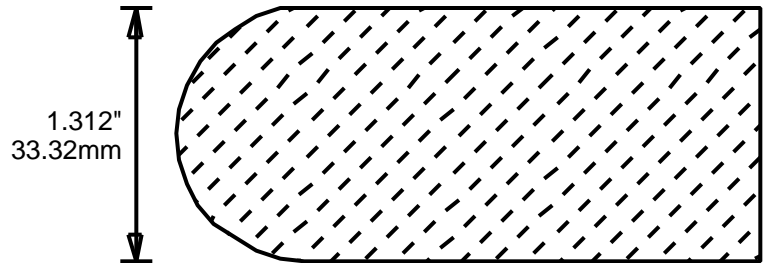

BULL 1500

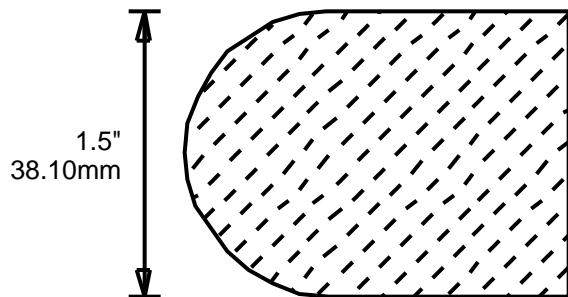

Specify Thickness When  
Ordering a Bullnose

Specify Thickness and Radius  
When Ordering

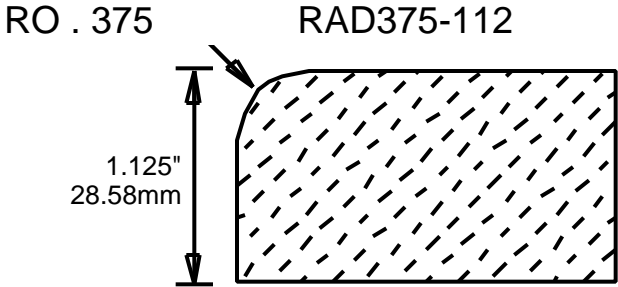
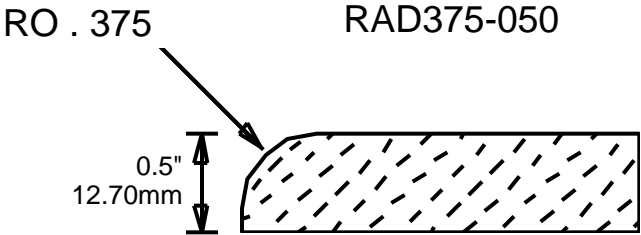
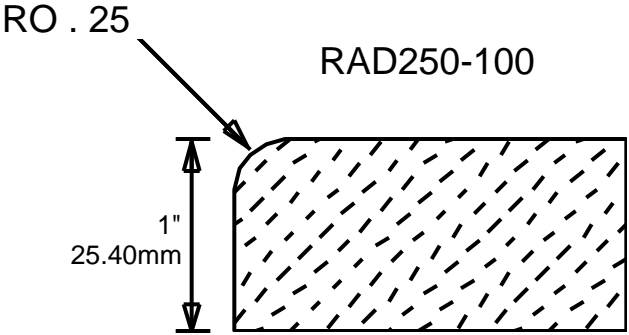
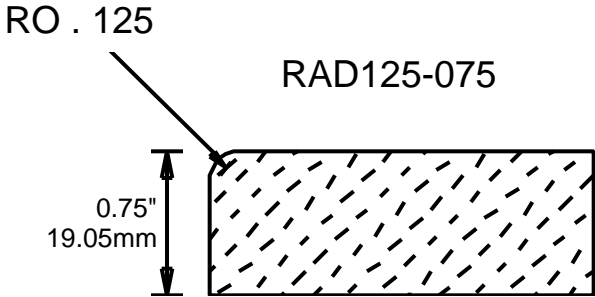
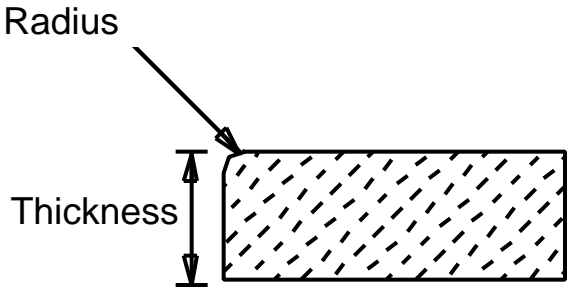

# WEINIG EASED 4 EDGES

Specify Thickness and Radius  
When Ordering

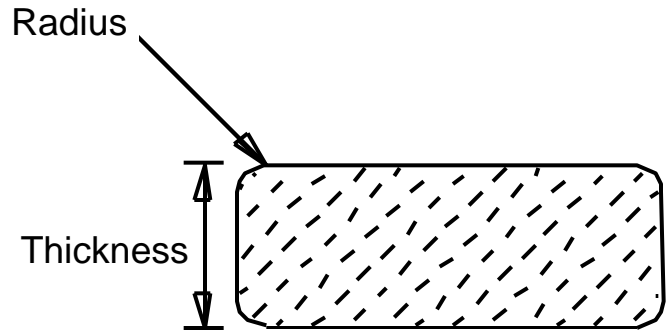

R0.062

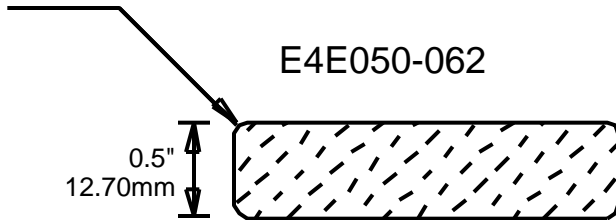

RO .125

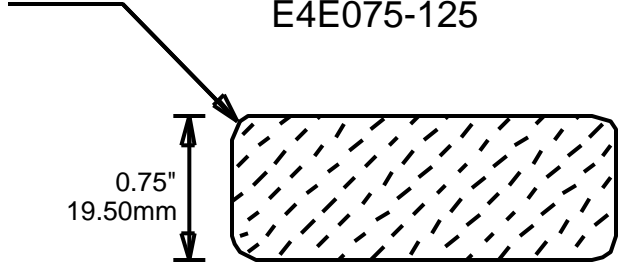

RO .25

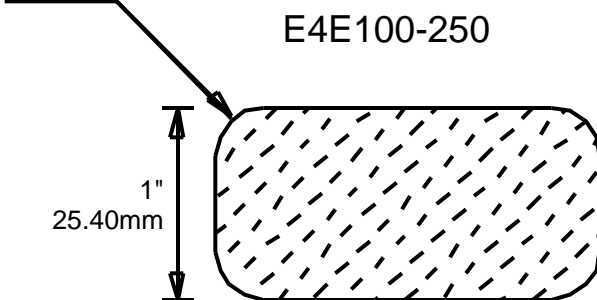

RO .375

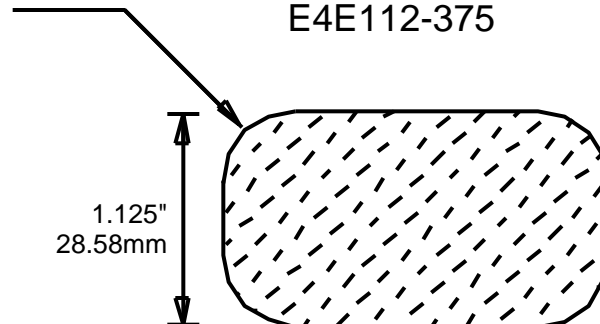

## NAVIGATION WITHIN THE PROFILE CATALOG DOCUMENT

Navigation in the Online Profile Catalog is similar to navigating through a website. There are links on every page to allow you to move from page to page easily. Within each section you can also navigate by using the Page Up and Page Down keys. At any time you may print the page or section you are viewing by clicking on the Print button on each page. When you click on the Print button, the print dialog box will appear on the screen, giving you all printing options you normally have with your printer. Please note that the Acrobat document is a low-resolution output file; therefore, it will not produce the high-quality output found in the printed version of the Profile Catalog.

### ALSO AVAILABLE

A bound version of this catalog is also available by contacting Michael Weinig Inc. at 704-799-0100, or via e-mail at [grinding@weinig.com](mailto:grinding@weinig.com). Also, visit our website at [www.weinigusa.com](http://www.weinigusa.com).

***RETURN TO  
Table of Contents***